

Hybrid 7 Foamatic

MA2, MA3, MA2M, MA3M, MA2I, MA3I, MA2IM, MA3IM
SA2IM, SA3IM, SA2I, SA3I



**Software Manual
for Multicontroller**



Available manuals for this unit:

110009190 / 110009193 Direction for use - Hybrid 7 Foamatic MA/SA
110009191 / 110009194 Userguide - Hybrid 7 Foamatic MA/SA
110009192 / 110009195 Software manual - Hybrid 7 Foamatic MA/SA

110009305 Installation manual Hybrid 7 Foamatic I/O Extension module (Accessory)

Where to find them :

Direction for use and Userguide will be enclosed as physical paper manuals with the unit.

The software manual must be downloaded from www.nilfiskfood.com - in order to ensure that you always have the latest updated version. (It is not supplied with unit in paper form).

Installation manual Hybrid 7 Foamatic I/O Extension module will be enclosed as physical paper manuals with the extension module purchased as an accessory.

At any given time, all manuals can be obtained online at www.nilfiskfood.com.

1. Contents

2. Description	9
2.1. Mainmenu	9
2.2. Navigation	9
2.3. Find the specific screen or subscreen	9
3. Symbols, buttons and icons	10
3.1. Symbols used in regards to wash steps	11
4. Password protection setup / change	12
4.1. Change PIN Code for Auto / as Manager	12
4.2. Change PIN Code for Auto / as Service	12
4.3. Change PIN Code for Manager / as Manager	13
4.4. Change PIN Code for Manager / as Service	13
4.5. Change Manager name / as Service	14
4.6. PIN Code for Service	15
5. Auto - Automatic Cleaning	16
5.1. Starting a wash program	16
5.2. Pause a wash program	18
5.3. Stop a wash program	18
6. Manual - Manual cleaning	19
6.1. Start manual cleaning	19
6.2. Preset pressure buttons	20
6.3. Change preset pressure buttons	20
6.4. Stop manual cleaning	21
7. Manager	22
7.1. Setup and changes / as Manager	22
7.2. Settings / as Manager	23
7.3. Port Function / as Manager	23
7.4. Foamatic / as Manager	24
7.5. Manual - Managers test mode	24

8. Service	25
8.1. How to use Service menu	25
8.2. Settings / as Service	26
8.2.1. Preset pressure for Manual outlet	26
8.2.2. Post run time	27
8.2.3. Dry run level.....	27
8.2.4. Acceleration Ramp	27
8.2.5. Startup Method (Flow).....	27
8.2.6. Quick Start	28
8.2.7. Startup Method (Pressure).....	28
8.2.8. Screen saver	28
8.2.9. Unit type	28
8.2.10. Clock/Date	29
8.2.11. Time zone.....	29
8.2.12. PIN Code change for manager (Only as Manager).....	30
8.2.13. Change of Machine type (Only as Service).....	30
8.2.14. Select Brand (Only as Service).....	31
8.2.15. Reset to Default (Only as Service).....	31
8.3. Port Function / as Service	32
8.4. Foamatic / as Service	33
8.4.1. Wash Program / as Service	34
8.4.1.1. Set Program Pause Time	34
8.4.2. Wash Step / as Service.....	35
8.4.3. Area Names / as Service	35
8.4.4. Product Names / as Service	35
8.4.5. Setup Detergent / as Service	36
8.4.6. IO Modules / as Service	36
8.4.7. Toggle Manual Valve / as Service	37
8.4.8.8. Adjust the flowswitch on manual outlet.....	37
8.5. Users / as Service	37
8.6. Upgrade Software / as Service	37
8.7. Manual / as Service	38
8.7.1. Manual mode graphic overview	39
8.8. Quick guide setup - Step by Step / as Service.....	40
8.8.1. Select Machine Type	40
8.8.2. Add external I/O Modules (Accessory / Add on)	40
8.8.3. Area Name - Setup	41
8.8.4. What is Inputs, Inputs available and their functionality	42
8.8.4.1. Start Program	42
8.8.4.2. Stop Program	42
8.8.4.3. Pause Program.....	42
8.8.4.4. Release Program.....	42
8.8.4.5. Release Hold Program	42
8.8.4.6. Lance Empty.....	42
8.8.4.7. Lance Low	42

8.8.4.8.	External Error	42
8.8.4.9.	External Activation	42
8.8.4.10.	Release	42
8.8.4.11.	Blocked.....	42
8.8.4.12.	Safety active	42
8.8.5.	Add Input - How to add Input signals	43
8.8.6.	What is Outputs, Outputs available and their functionality	45
8.8.6.1.	Area Valve	45
8.8.6.2.	Program Active	45
8.8.6.3.	Program Finish	45
8.8.6.4.	System Active	45
8.8.6.5.	System Not Active	45
8.8.6.6.	System Ready	45
8.8.6.7.	Manual Cleaning.....	45
8.8.6.8.	Running	45
8.8.6.9.	Not Running.....	45
8.8.6.10.	Error.....	45
8.8.6.11.	No Error	45
8.8.6.12.	Stopped	45
8.8.6.13.	External Release	45
8.8.6.14.	Hot Water Valve.....	45
8.8.7.	Add Output - How to add Output signals.	46
8.8.8.	Remove Input / Output signals	48
8.9.	Show I/O's connected or in use	50
8.9.1.1.	Output Port State,	50
8.9.2.2.	IO - Module Input Port State - 1/2,	50
8.9.3.3.	IO - Module Input Port State - 2/2,	51
8.9.4.4.	IO - Module_2 Input Port State - 1/2,	51
8.9.5.5.	IO - Module_2 Input Port State - 2/2,	51
8.9.6.6.	IO - Module_3 Input Port State - 1/2,	52
8.9.7.7.	IO - Module_3 Input Port State - 2/2,	52
8.9.8.8.	IO - Module Output Port State - 1/2,	52
8.9.9.9.	IO - Module Output Port State - 2/2,	53
8.9.10.10.	IO - Module_2 Output Port State - 1/2,	53
8.9.11.11.	IO - Module_2 Output Port State - 2/2,	53
8.9.12.12.	IO - Module_3 Output Port State - 1/2,	54
8.9.13.13.	IO - Module_3 Output Port State - 2/2,	54
8.9.14.	Wash steps.....	55
8.9.14.1.	Add Wash Step.....	55
8.9.14.2.	Edit Wash Step.....	58
8.9.14.3.	Delete Wash Step.....	60
8.9.15.	Wash Programs.....	61
8.9.15.1.	Create wash program.....	61
8.9.15.2.	Edit wash program.....	64
8.9.15.3.	Delete wash program	66
8.9.15.4.	Program PIN Code	66

9. Info	67
9.1. Where to find "Info" menu	67
9.1.1. What kind of data to find in "Info".	67
9.1.2.2. Machine type	67
9.1.3.3. IP Address	67
9.1.4.4. MAC Adress	67
9.1.5.5. Serial Number	67
9.1.6.6. Controller SW version	68
9.1.7.7. GUI SW version	68
9.1.8.8. Modbus SW version	68
9.1.9.9. Inverter SW version	68
9.1.10.10. On Time	68
9.1.11.11. Run Time	68
9.1.12.12. Power	68
9.1.13.13. Install time	68
9.1.14.14. Clock/Date	68
9.1.15.15. On Time	69
9.1.16.16. Run Time	69
9.1.17.17. Power	69
9.1.18.18. Last Reset	69
9.1.19.19. Reset button	69
10. Error Log	71
10.1. Cause/Remedy	72
11. Software update	76
11.1. Hardware needed to update software	76
11.2. Download of the new software	76
11.3. Update files and their functions	77
11.4. Installation of the updates	77
12. I/O Modul setup	81
12.1. Add I/O Module	81

2. Description

This Software manual describes the operation of the multicontroller.
The multicontroller has a touch screen panel divided into following sections:

Auto: Press Auto to start automatic cleaning

Manual: Press Manual to start manual cleaning

Manager : Press Manager to set up time, date, parameters and unit variables

Service : Press Service to set up time, date, wash programs, wash steps etc.

Info : Press Info to see machine type, software version, run time and installation time.

Error Log: Press error log to see the latest errors / warnings (up to 200 logs)

2.1. Mainmenu

The multicontrollers screen is a touch screen with a main menu divided in two sections:

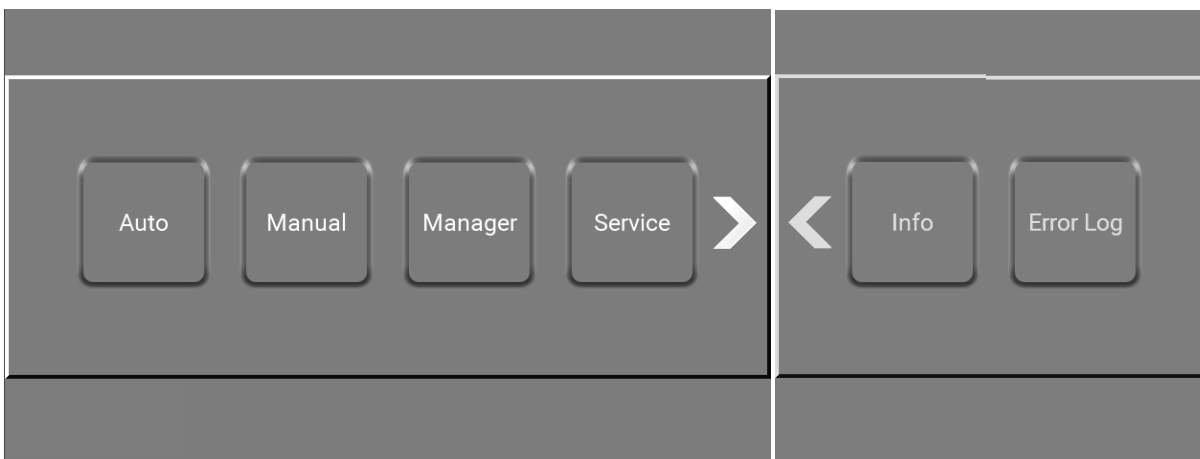

Underneath each picture you will find the path to the display\

2.2. Navigation

The navigation goes through a series of screens and subscreens in a graphic user interface (GUI). Each menu consists of buttons that lead the user into the system's functions and options. Some of the menus have more than 4 buttons or functions on the user interface. If this is the case, an arrow will appear to the right, giving the user the option to access the additional buttons and functions by pressing the arrows.

2.3. Find the specific screen or subscreen

Below each picture in this software manual there is a path like in Windows Explorer to the specific screen or subscreen. It could look like this :

\Mainmenu\Manager\Menu\Settings\RightClick6\...

Mainmenu\	is the first mainmenu on the multicontroller.
Manager\	is the button in the mainmenu.
Menu\	is a button on the 1 level subscreen.
Settings\	is a button on the 2 level subscreen.
RightClickPic6\	press right arrow 6 times to see this subscreen.
...	something is shown in the illustration e.g. is active, is changed and etc.

3. Symbols, buttons and icons

This is an introduction to the symbols, buttons and icons, that you as a user will encounter while using this satellite or mainstation.

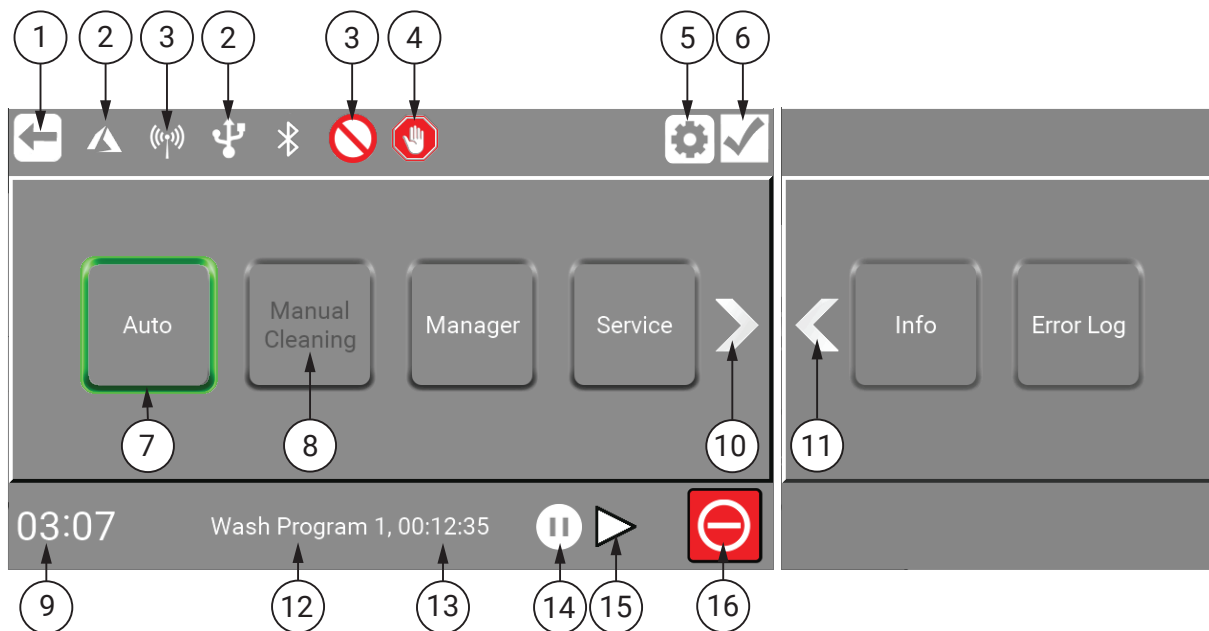

- 1 **Return** - Step backward.
- 2 **USB** - The unit is connected to USB.
- 3 **Release** - The unit is not released.
- 4 **Blocked** - The unit / is blocked.
- 5 **Settings** - Go to the settings menu.
- 6 **Confirm** - A choice, value etc.
- 7 **Green light frame** - The unit / program is running are active.
- 8 **Disabled button** - Another function is conflicting with the use of this function.
- 9 **Current time** - Clock / CET.
- 10 **Move right** - Through menus with more than 4 buttons.
- 11 **Move left** - Through menus with more than 4 buttons.
- 12 **Program name** - On active program.
- 13 **Countdown time** - On active program.
- 14 **Pause** - The unit / program.
- 15 **Start** - The unit / program after a pause.
- 16 **STOP** - The unit / program.

3.1. Symbols used in regards to wash steps

Here a view of the symbols used in wash steps are shown.
For a guide how to use it go to : "8.9.14. Wash steps" on page 55



\\Mainmenu\ManagerOrService\PIN\Menu\Foamatic\RightClick1\.

Activate Output: function used to let the wash step/program activate an output of the PLC, it could for example be a zone valve, active signal etc. When pressing this symbol a list of available output functions will appear.

Deactivate Output: function used to let the wash step/program deactivate an output. Always make sure outputs activated by previous symbol is also deactivated. The same list as for activating output will appear.

Wait for input: function used when a wash step/program should wait for a given signal before continuing. It could be a feedback signal from a zone valve telling that the zone is actually open or closed.

Wait Time: This function is used to place an adjustable pause in a wash step; the period of the pause is set when creating a wash program. An example could be the time between opening and closing a valve.

Action Pause: this is a pause defined in the wash step; it could for example be a short pause waiting for a valve to close.

4. Password protection setup / change

The unit has different kinds of password levels.

To enable / disable or change password protection, see permissions and how to below.

4.1. Change PIN Code for Auto / as Manager

The password protection for the Auto / Automatic Cleaning button is optional.

As manager it is possible to enable / disable or change the "Auto" password here :

Go to \Mainmenu\Manager\PIN\Menu\Foamatic\WashProgram\ProgramPINCode\

1. Enable / disable password protection.

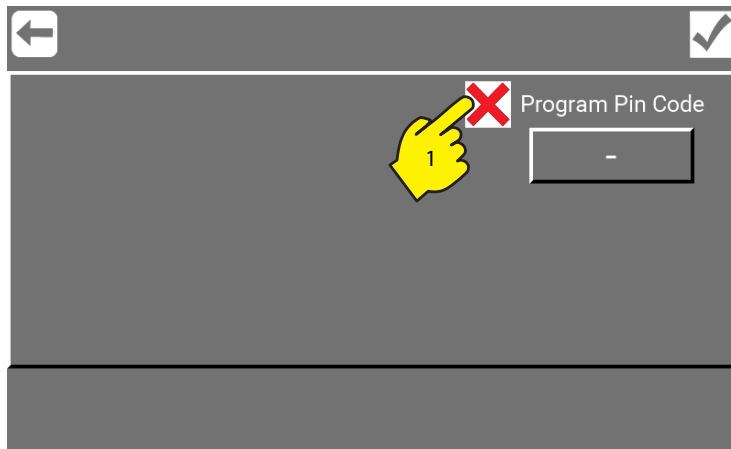

\Mainmenu\Manager\PIN\Menu\Foamatic\WashProgram\ProgramPinCode\

2. Enter new code and complete with OK.
3. Confirm the password change.

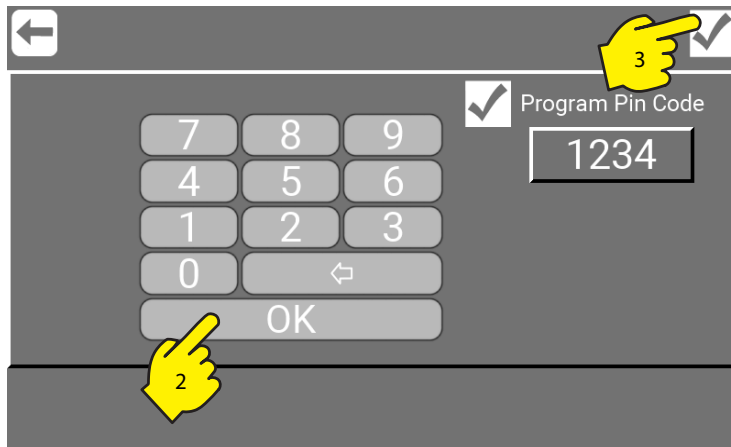

\Mainmenu\Manager\PIN\Menu\Foamatic\WashProgram\ProgramPinCode\...

4.2. Change PIN Code for Auto / as Service

The password protection for the Auto / Automatic Cleaning button is optional.

As Service it is also possible to enable / disable or change the "Auto" password here :

Go to \Mainmenu\Service\PIN\Menu\Foamatic\WashProgram\ProgramPINCode\

This is done the same way as : "4.1. Change PIN Code for Auto / as Manager" on page 12

4.3. Change PIN Code for Manager / as Manager

The password protection for the Manager button is required and cannot be disabled.
As Manager it is also possible to change the Manager PIN code (By default : 6802) here :

Go to \Mainmenu\Manager\PIN\Menu\Settings\RightClick6\

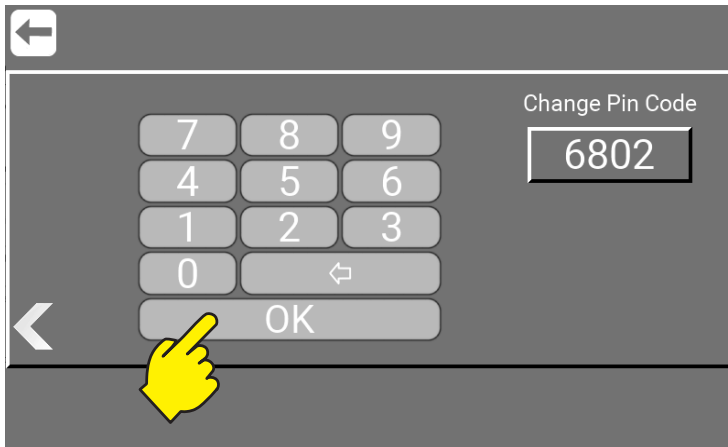

\Mainmenu\Manager\PIN\Menu\Settings\RightClick\Foamatic\WashProgram\ProgramPinCode\

4.4. Change PIN Code for Manager / as Service

As Service it is possible to change the Manager PIN Code here:

Go to \Mainmenu\Service\PIN\Menu\Users\Manager\

1. Press field with PIN code.

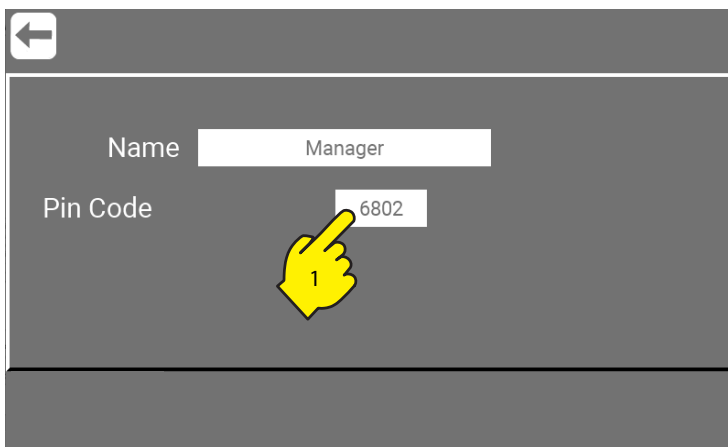

\Mainmenu\Service\PIN\Menu\Users\Manager\...

2. Enter new code and complete with OK.

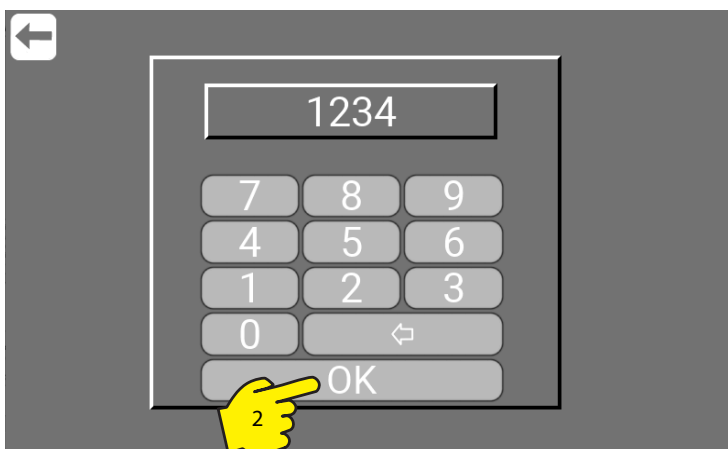

\Mainmenu\Service\PIN\Menu\Users\Manager\...

3. Confirm the password change.

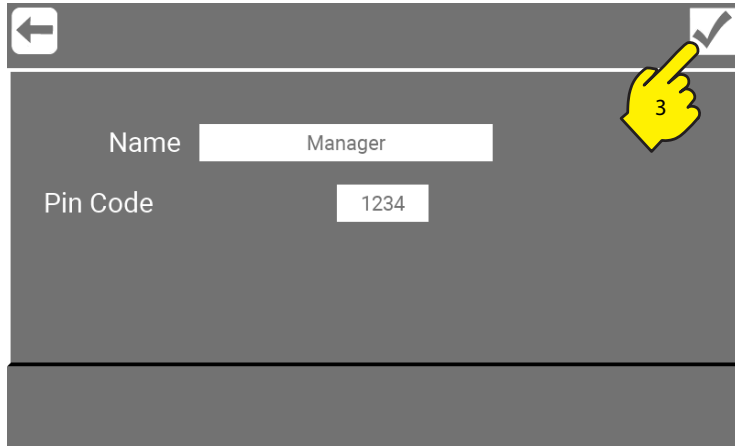

Mainmenu\Service\PIN\Menu\Users\Manager\...

4.5. Change Manager name / as Service

As Service it is also possible to change the Manager name here:

1. Press field with Name.

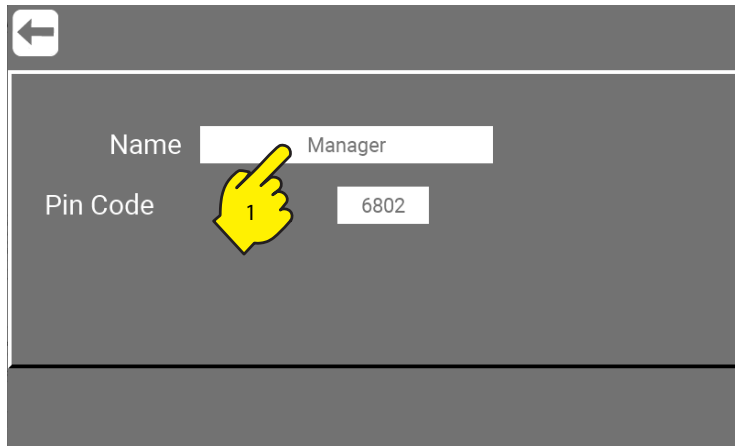

Mainmenu\Service\PIN\Menu\Users\Manager\...

2. Enter new name and press confirm.



Mainmenu\Service\PIN\Menu\Users\Manager\...

3. Confirm the name change.

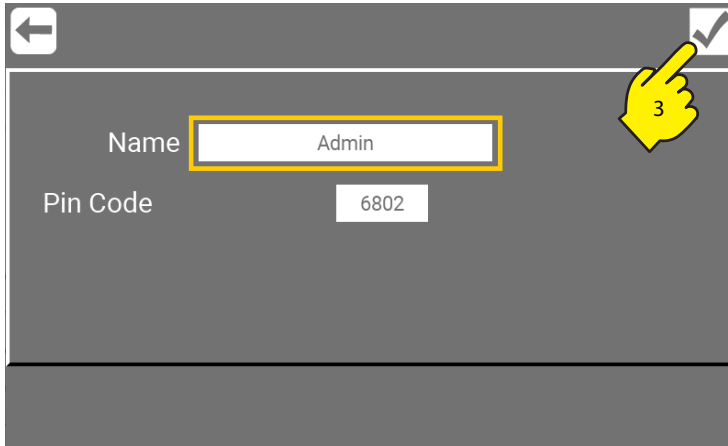

Confirm the name change.

Name Admin

Pin Code 6802

\\Mainmenu\Service\PIN\Menu\Users\Manager\...

4. Manager button in mainmenu is now changed to "Admin".

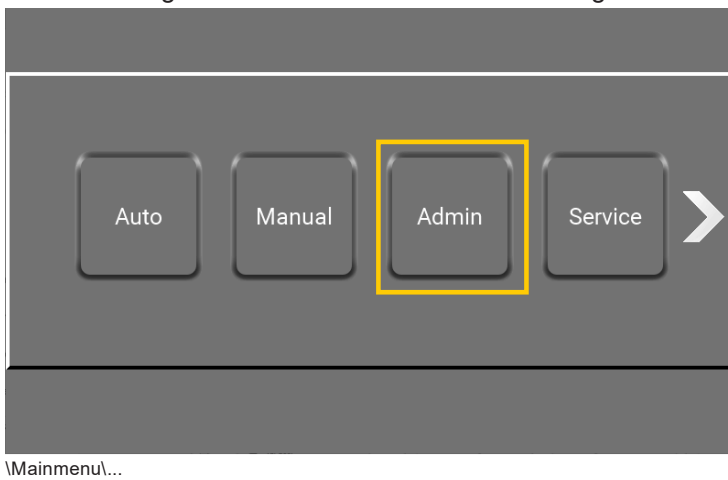

4.6. PIN Code for Service

The password protection for the Service button is required and cannot be disabled or changed.

If "Service" password is required, please contact your supplier.

5. Auto - Automatic Cleaning

Start and stop of automatic cleaning wash programs.

5.1. Starting a wash program

Press "Auto" in main menu.

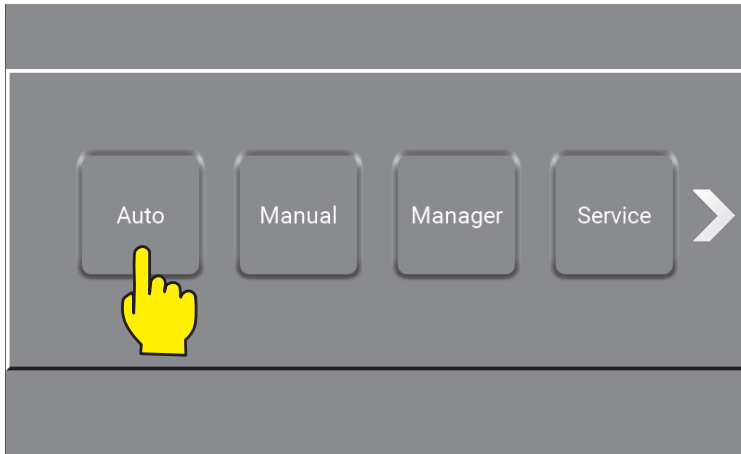

\\Mainmenu\

The Auto button in main window can be password protected. If so, a numeric keypad will appear. To enable / disable or change the "Auto" password, go to "4.1. Change PIN Code for Auto / as Manager" on page 12 Enter the correct code and confirm with OK:



\\Mainmenu\Auto\

Select program.

When you press the button for the required automatic wash program it will start running right away.

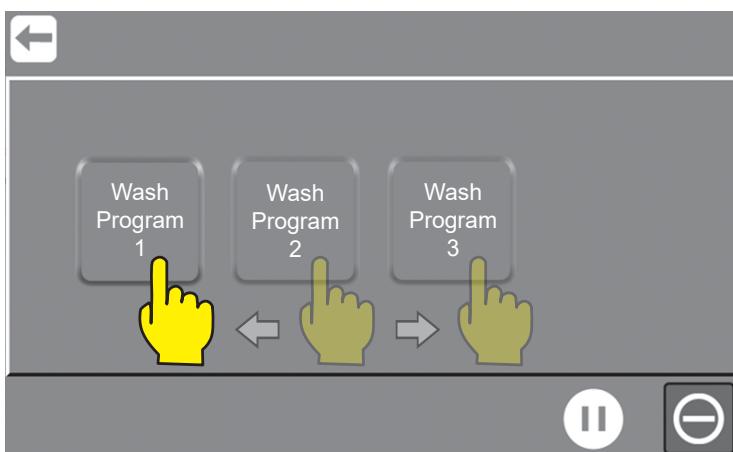

\\Mainmenu\Auto\"PIN\"

Together with the name of the active wash program, pressure, product, area and remaining time is shown in the white bar. When the first wash step is done, the next step will automatically start up. This will continue until the entire wash program has been completed or until the pause or stop button is activated.

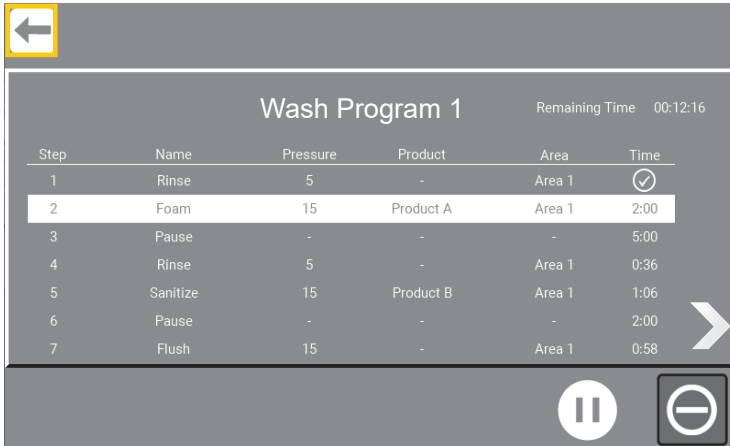

\\Mainmenu\Auto\PIN\WashProgram1\...

When you press the return button the active wash program will light up green until the program is done. The information text below will display: which program is running.

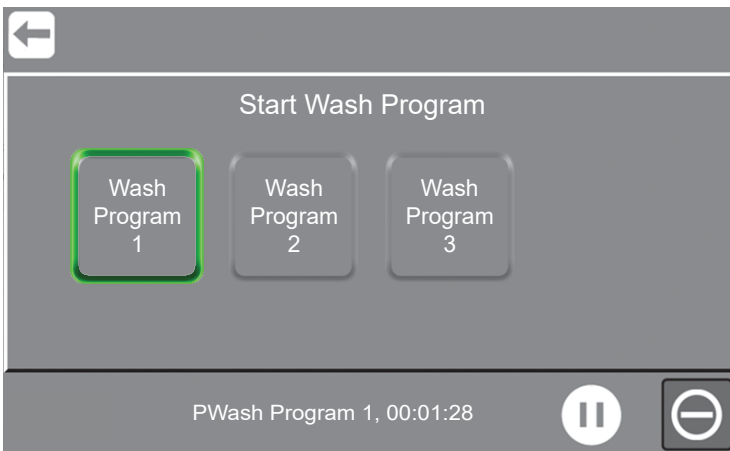

\\Mainmenu\Auto\PIN\...

When you press the return button again Auto will light up green until the program is done. Manual Cleaning is inactive until automatic wash program is done.

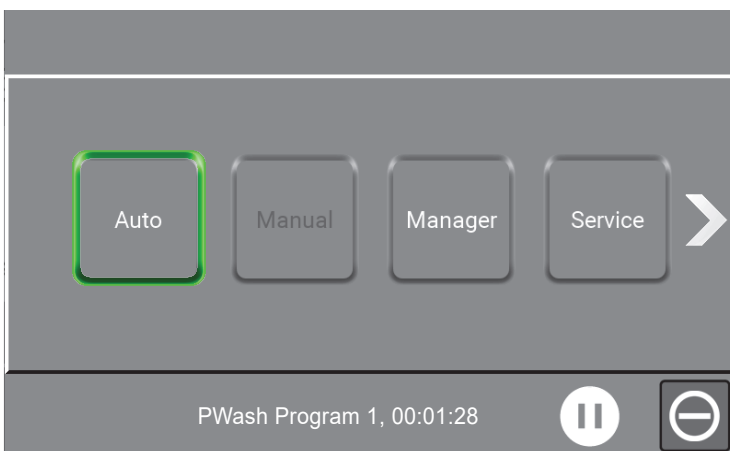

\\Mainmenu\

5.2. Pause a wash program

When a wash program is active the screen will look like this.

To pause a program press the pause button, the start button will appear to indicate that the unit is on pause. All valves are closed and the pause time out initiated. This time out as default set to 10 minutes, but can be adjusted, see "8.4.1.1. Set Program Pause Time" on page 34

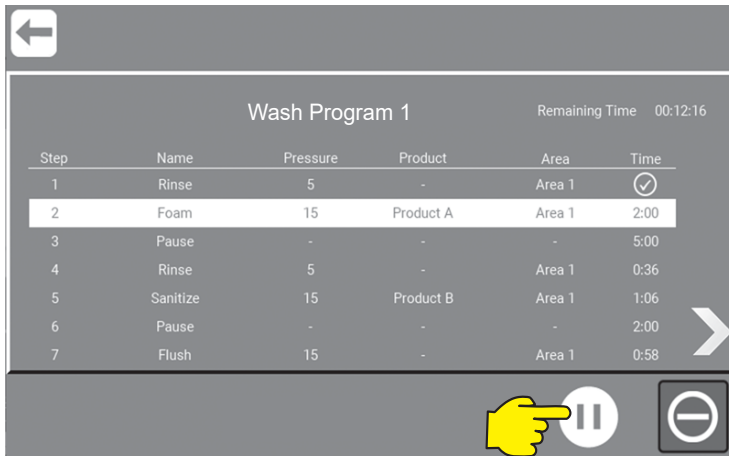

/Mainmenu\Auto\Wash Program 1\...

To restart the program - press the start button.

The pause button will re-appear, and the program will continue from the position where it was paused.

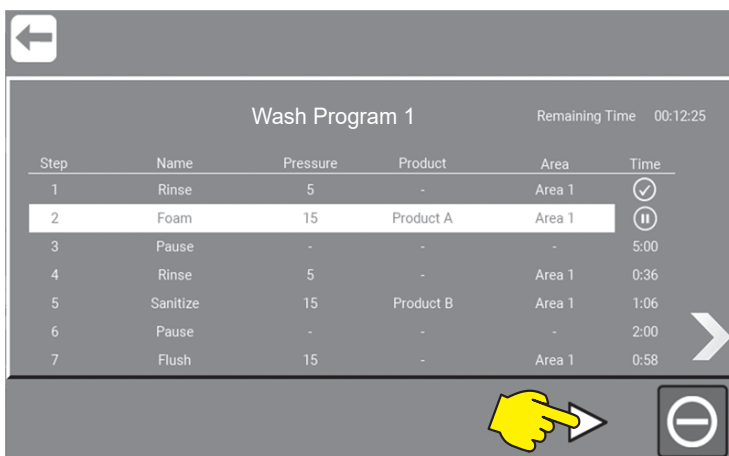

/Mainmenu\Auto\Wash Program 1\...

5.3. Stop a wash program

To stop an ongoing wash program press the stop button.

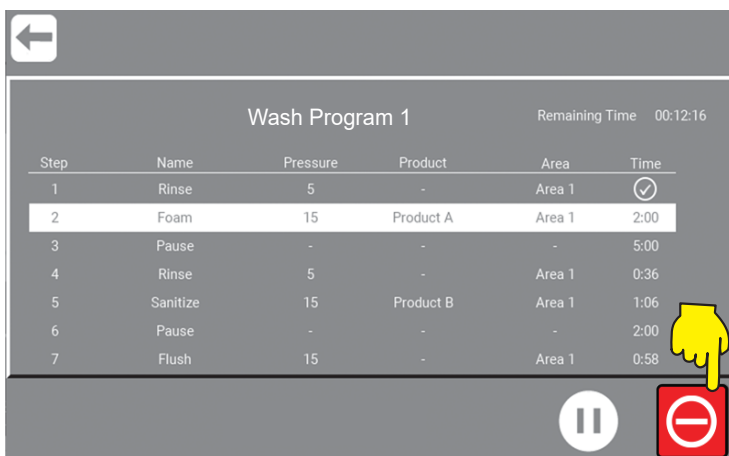

/Mainmenu\Auto\Wash Program 1\...

After pressing the stop button, the green indication will disappear.

It is now possible to select another program or reactivate the same program again.

6. Manual - Manual cleaning

6.1. Start manual cleaning

To enable manual cleaning, using a manual block or a mainstation / satellite, press the Manual button.

* If the unit is without a manual block, the manual button will not be visible, and activation of the manual function is not possible.

Press "Manual" button in home menu.

Manual cleaning is now active and will start running when there is flow.

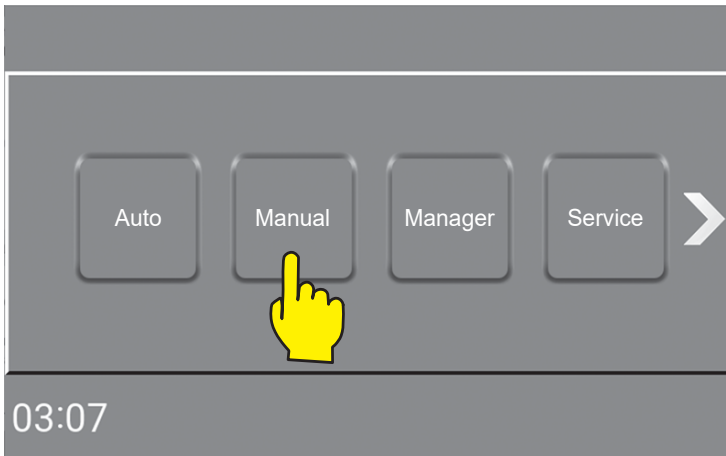

\\Mainmenu\

To see more data on the running unit, press "right arrow".

"Return" will send user back to the main menu. See "3. Symbols, buttons and icons" on page 10

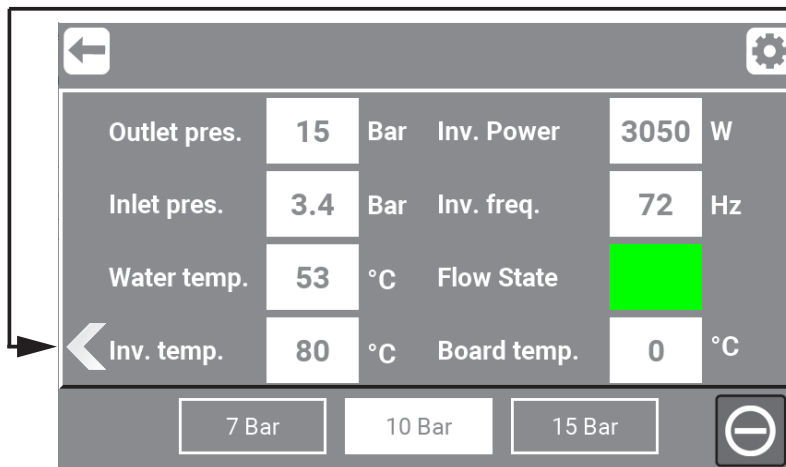
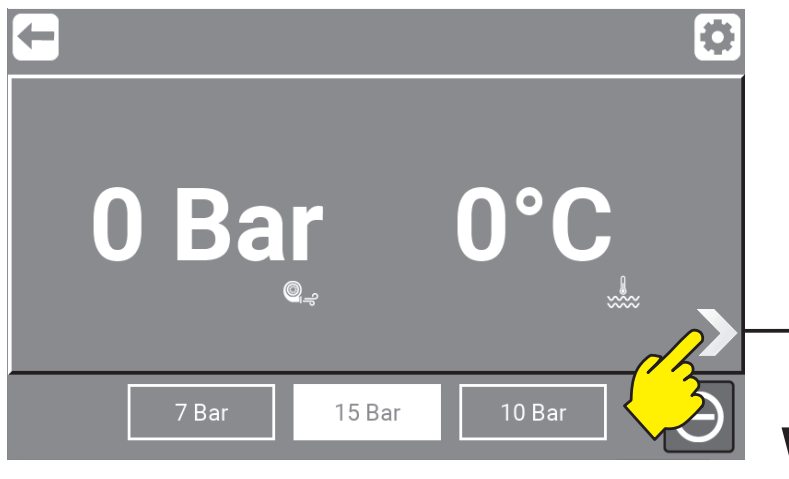

\\Mainmenu\\Manual\\Rightclick1\

6.2. Preset pressure buttons

Press the required preset pressure button e.g. "15 Bar" to change pressure.

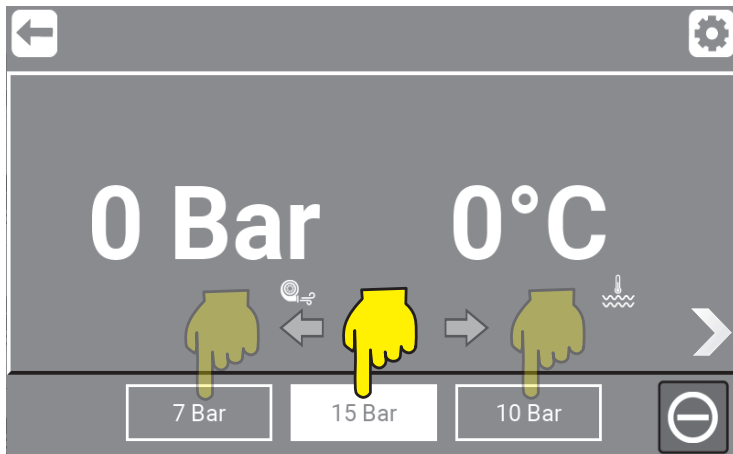

Mainmenu\Manual\...

6.3. Change preset pressure buttons

These 3 preset buttons can be adjusted by pressing "Settings".

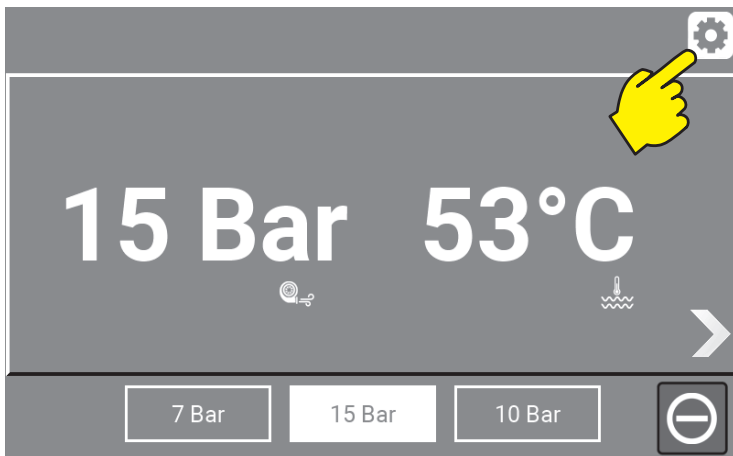

Mainmenu\Manual\PresetButton\...

Press up or down arrow until the desired setting is reached.

Min.7 Bar and max 15 Bar.

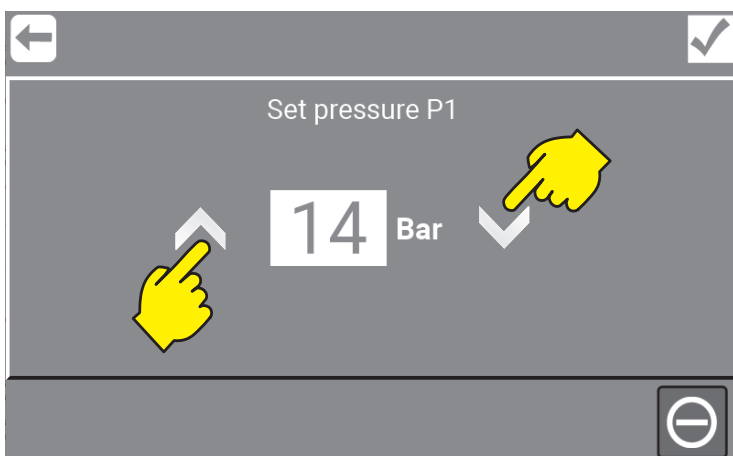

Mainmenu\Manual\PresetButton\Settings\...

"Confirm" to approve and store.

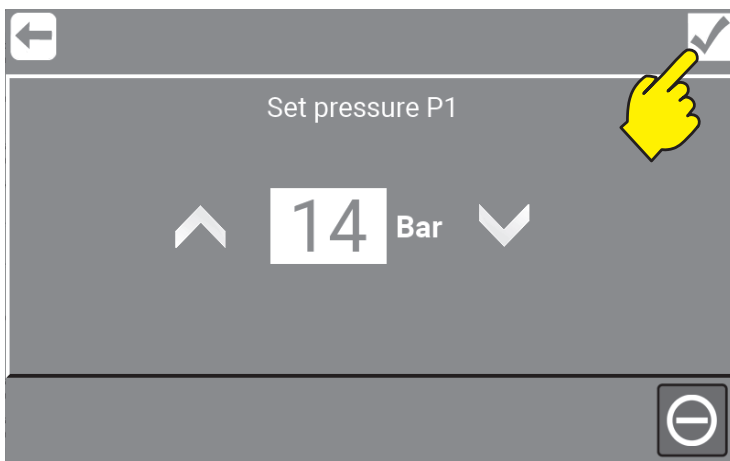

\\Mainmenu\Manual\PresetButton\Settings\...

The adjusted pressure will be stored for the next manual cleaning and on all user levels.

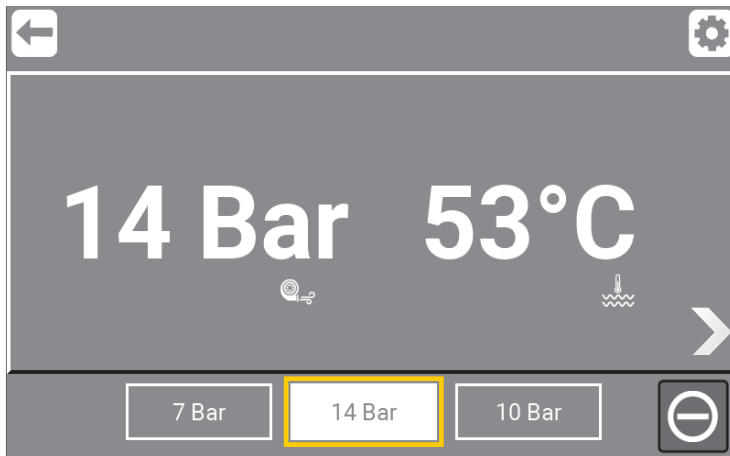

\\Mainmenu\Manual\PresetButton\Settings\Confirm\...

"Return" will send user back to the main menu.

6.4. Stop manual cleaning

To end manual cleaning, press stop.

After pressing the stop button, the green indication will disappear.

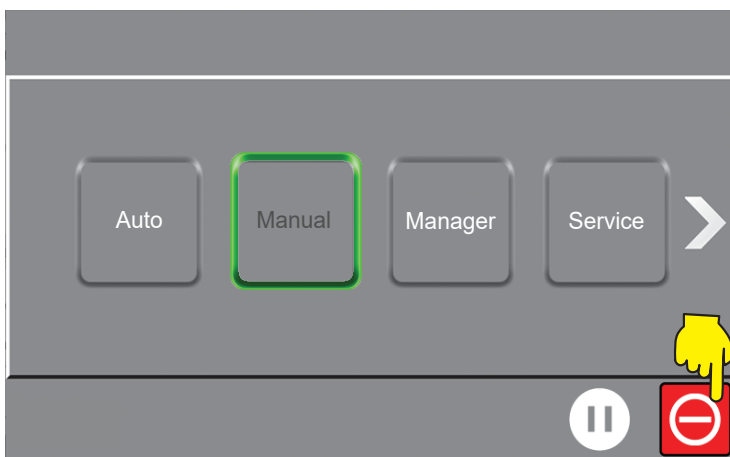

\\Mainmenu\

It is now possible to select another program or reactivate the same program again.

7. Manager

The Manager function has permissions to make functional changes and adjustments as Wash Programs, I/O settings and other settings for "Users" and "Manager". For setup of the entire system, adding I/O modules and software changes e.g. Service access is needed, for this go to "8. Service" on page 25

7.1. Setup and changes / as Manager

To set up time, date, parameters and unit variables, press the "Manager" button in the main menu.

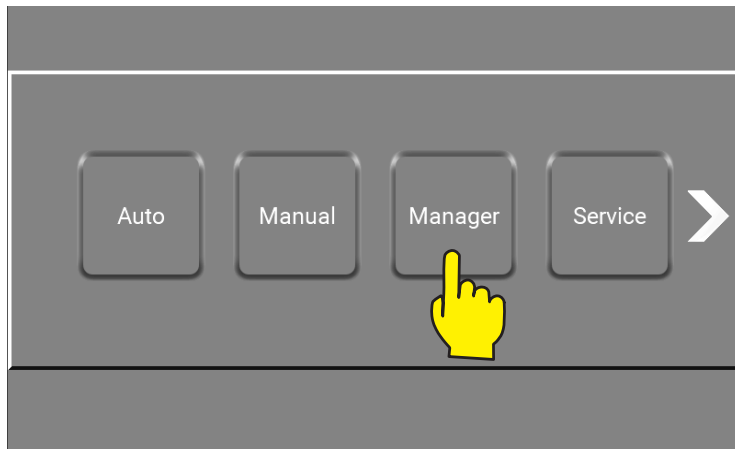

\Mainmenu\

The "Manager" button in main menu is password protected and a numeric keypad will show up. This password can be changed, see "5.2.11. PIN Code change for manager" on page 13. Enter the correct code and complete with OK. (By default : 6802)



\Mainmenu\Manager\

Press "Menu" button.

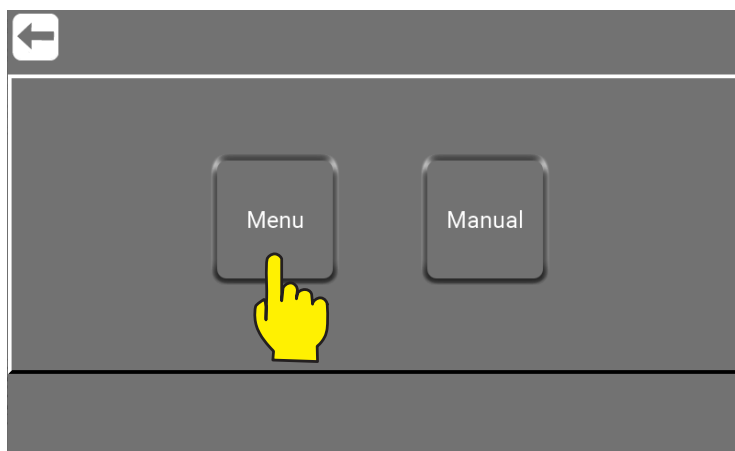

\Mainmenu\Manager\PIN\

Use of "Manual" as Manager go to : "7.5. Manual - Managers test mode" on page 24

7.2. Settings / as Manager

"Settings" menu for the manager, is very similar to Settings as Service.

To see complete menu and how to use it go to "8.2. Settings / as Service" on page 26

Press the "Settings" button.

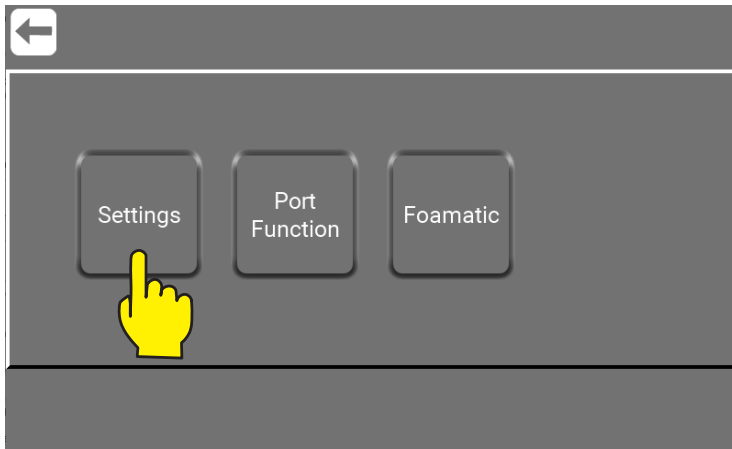

\\Mainmenu\Manager\PIN\Menu\Settings\

7.3. Port Function / as Manager

The Port function area as Manager is for working with Inputs and Outputs.

Press the "Port Function" button.

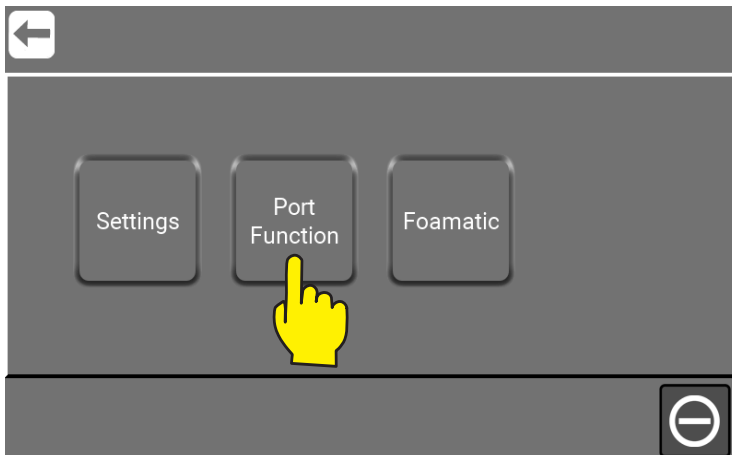

\\Mainmenu\Manager\PIN\Menu\...

Press the "Add Input" button.

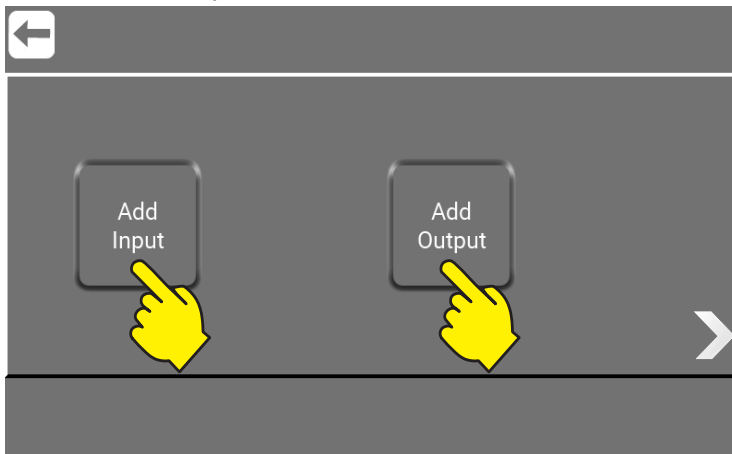

\\Mainmenu\Manager\PIN\Menu\PortFunctions\...

All about inputs and how to make their setup go to :

"8.8.4. What is Inputs, Inputs available and their functionality" on page 43

All about outputs and how to make their setup go to :

"8.8.6. What is Outputs, Outputs available and their functionality" on page 46

For a complete list of all inputs / output connected or in use go to :

"8.9. Show I/O's connected or in use" on page 50

7.4. Foamatic / as Manager

The Foamatic area in which the settings for the Foamatic system can be set and changed, like Wash Programs, Wash Steps, Areas etc.

"Foamatic / as Manager" is very similar to "Foamatic / as Service" for more and how to use it go to

"8.4. Foamatic / as Service" on page 33

Press the "Foamatic" button.

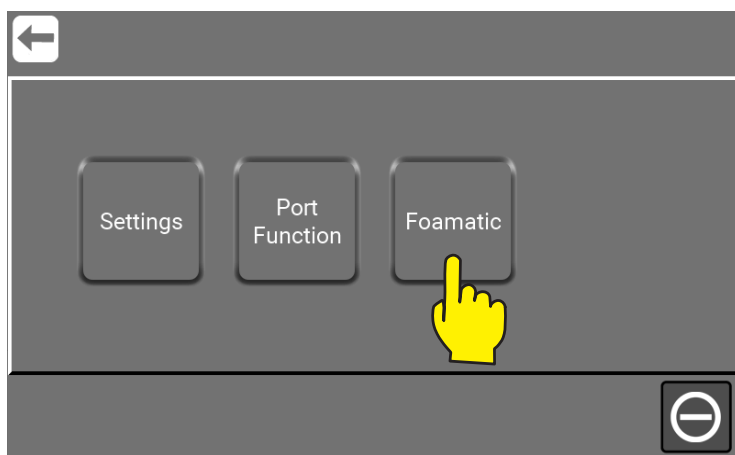

\\Mainmenu\Manager\PIN\Menu\...

7.5. Manual - Managers test mode

The Managers test mode (Manual) is a place to test if the unit's setup is as required.

Manager has access to the settings button in all sub-screens in here.

When pressing "Right Arrow" you will find a graphic overview with data from the running unit.

In here Manager can check data and make changes by pressing "Settings" anytime wanted.

Manual as "Manager" is very similar to Manual as "Service" for more and how to use it go to

"8.7. Manual / as Service" on page 39

Press the "Manual" button.

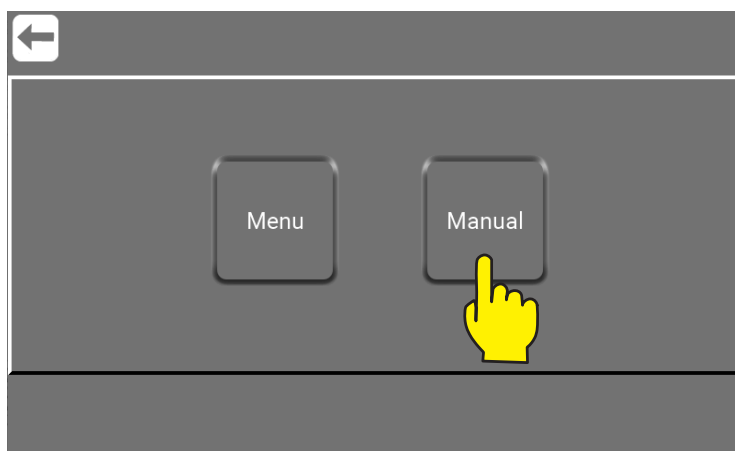

\\Mainmenu\Manager\PIN\...

8. Service

8.1. How to use Service menu

The service menu is for trained service personal only.

Here you can change the setup, make adjustments and changes in general. This on a higher level then Manager. Be aware that changes made in this area, might impact the functionality of your unit and cause that the unit runs poorly or even fails. Thorough training is required.

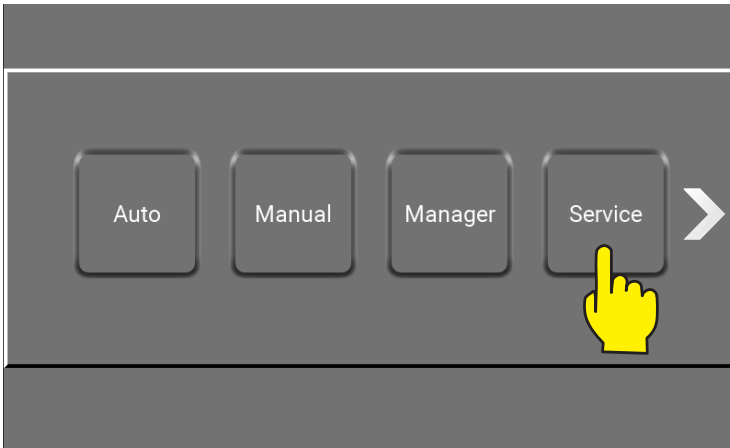

\\Mainmenu\\

The Service button in main menu is password protected and a numeric keypad will show up. For more about password protection see : "4. Password protection setup / change" on page 12

Enter the correct code and complete with OK.



\\Mainmenu\\Service\\...

Press the "Menu" button.

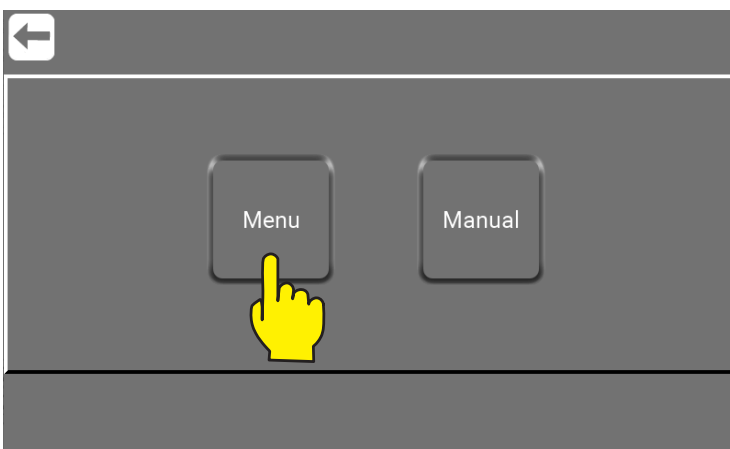

\\Mainmenu\\Service\\PIN\\...

8.2. Settings / as Service

"Settings / as Service" menu is almost the same as "Settings / as Manager", so all pictures are the same with the exception of the last 4 pictures. First one only for "Settings / as Manager" and last the 3 only for "Settings / as Service" on page 32.

Note : The **"Users"** and **"Upgrade Software"** (Here marked with yellow boxes.) is only available as Service.

Press the "Settings" button.

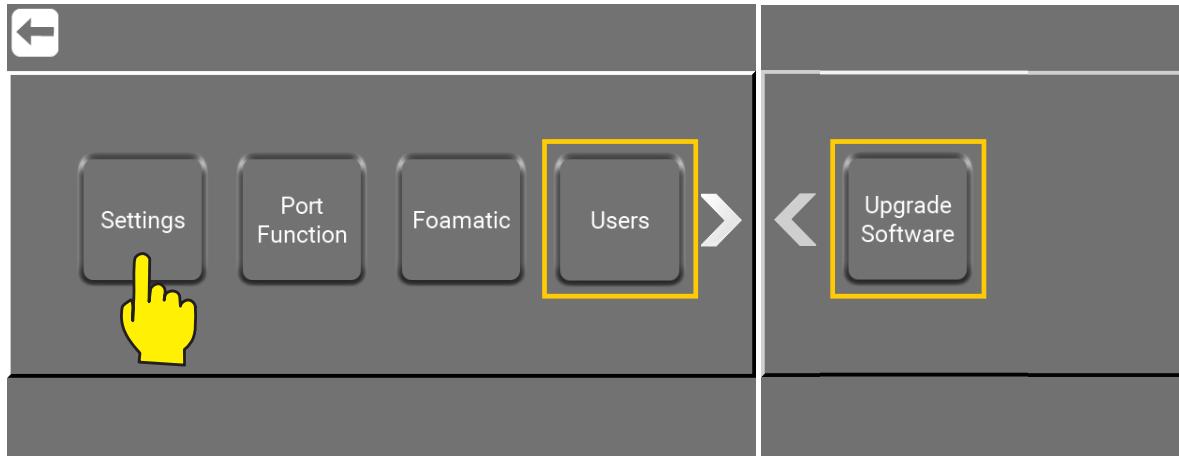

\\Mainmenu\ManagerOrService\PIN\Menu\...

In the "Settings" menu for service a long range of settings can be adjusted in order to change the behavior of the unit. Navigation through the settings menu is done using the right and left arrows.

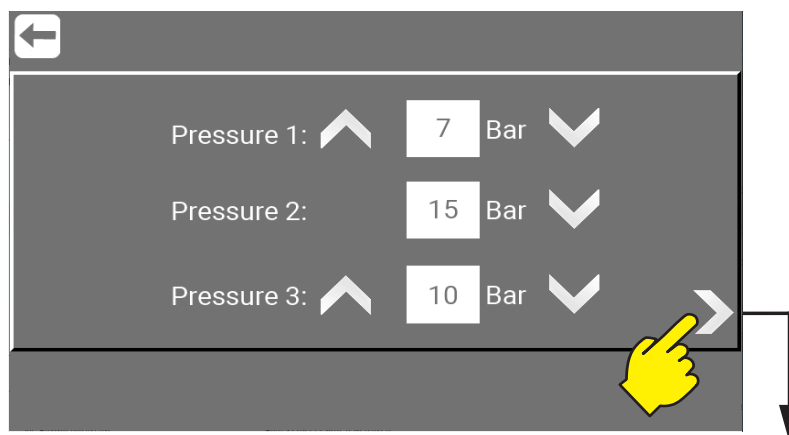

\\Mainmenu\ManagerOrService\PIN\Menu\Settings\

8.2.1. Preset pressure for Manual outlet

Set the preset pressure located in the Manual cleaning program.

Min. 3 Bar and max. 15 Bar. (Only units with Manual outlet)

See "4. Manual - Manual cleaning" on page 14).

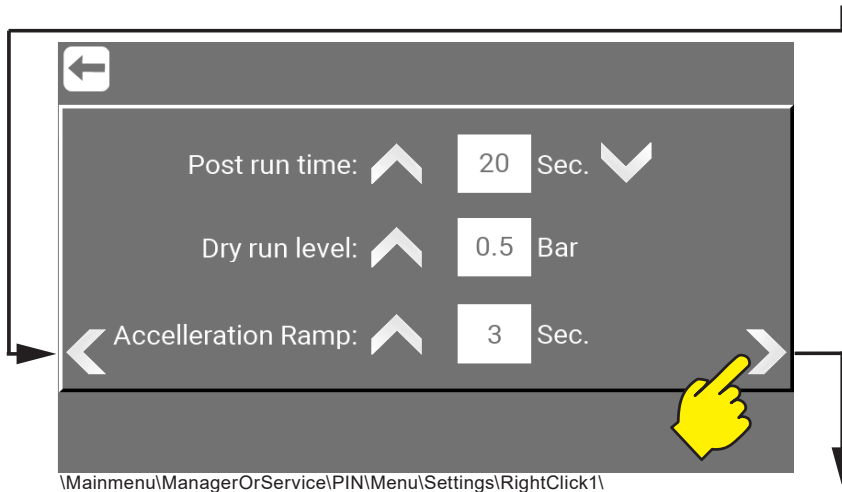

8.2.2. Post run time

This time interval is the time from the flow switch detects no flow until the pump stops. Min. 5 sec. and max. 60 sec. (Mainstation only).

8.2.3. Dry run level

Minimum Dry run level that the unit requires to run. Min. 0.5 Bar and max. 4 Bar. (Mainstation only).

8.2.4. Acceleration Ramp

The time it takes for the pump to accelerate from standing still until maximum speed is achieved (unregulated). Min. 3 sec. and max. 10 sec. (Mainstation only).

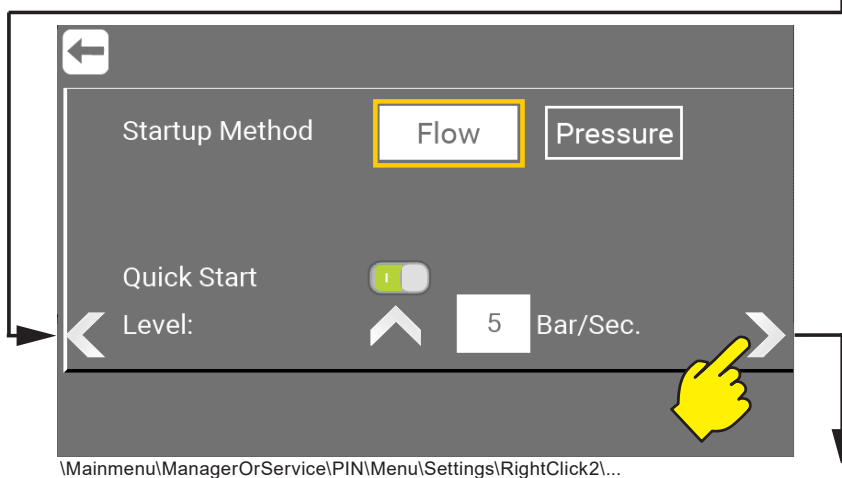

8.2.5. Startup Method (Flow)

As standard, the units factory setting for Startup method is Flow. For Startup method "Pressure" see: "8.2.7. Startup Method (Pressure)" on page 28

FLOW start, the pump will start as soon as the flowswitch detects a steady flow above: 2 L/min (Factory default setting), through the pipe system. The pump will then run until the flow is cut off or gets below 1.5 l/min. It is possible to set a postrun time, that allows the pump to continue to run for a selected amount of seconds, even without any flow detected. If the flow is re-established during postrun time, the pump will continue to run. It is possible to adjust the postrun time, see: "8.2.2. Post run time" on page 27

8.2.6. Quick Start

When the unit is in Flow start mode, it is possible to select “Quick Start” this function will when activated, monitor how the pressure is in the system and if it is dropping. And if so start the pump if the conditions are met e.g. 5 bar/second.

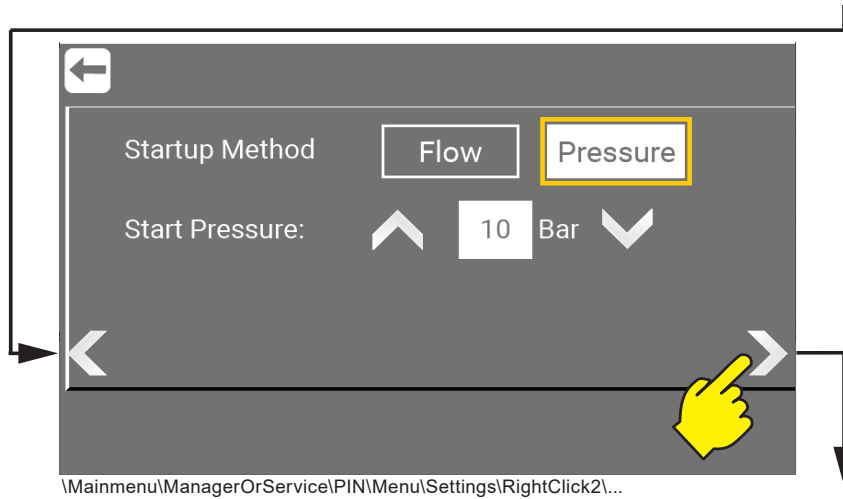

8.2.7. Startup Method (Pressure)

PRESSURE start, the unit will start when the pressure sensor detects a system pressure below the setpoint “Start pressure” and will remain running as long as the flow switch detects a flow in the system – the above mentioned “Postrun time” will apply to the pressure start method as well. It is possible to adjust the pressure using the arrows up or down – the value can be set between 3 and 15 bar.

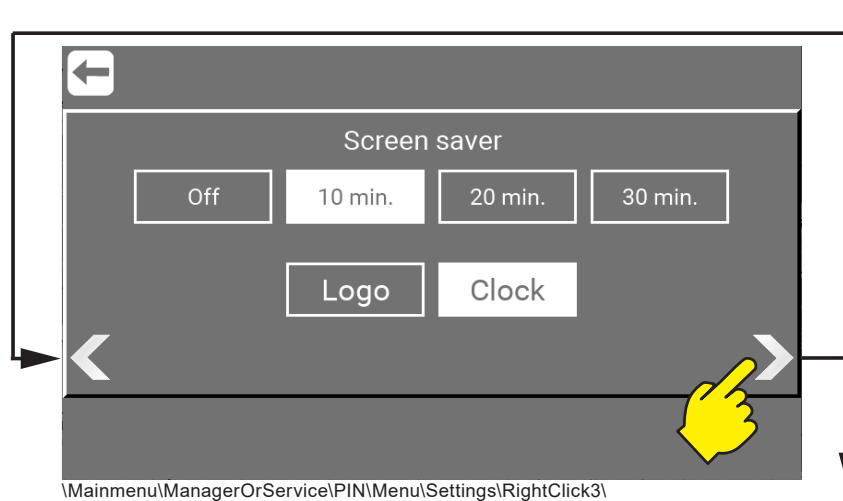

8.2.8. Screen saver

Set time for the screen saver. And choose if the screen saver should show Logo or Clock when activated.

8.2.9. Unit type

Select unit type of measure. Pressure and temperature.

SI Metric - Bars / Celcius or **Imperial** Gallons / Fahrenheit.

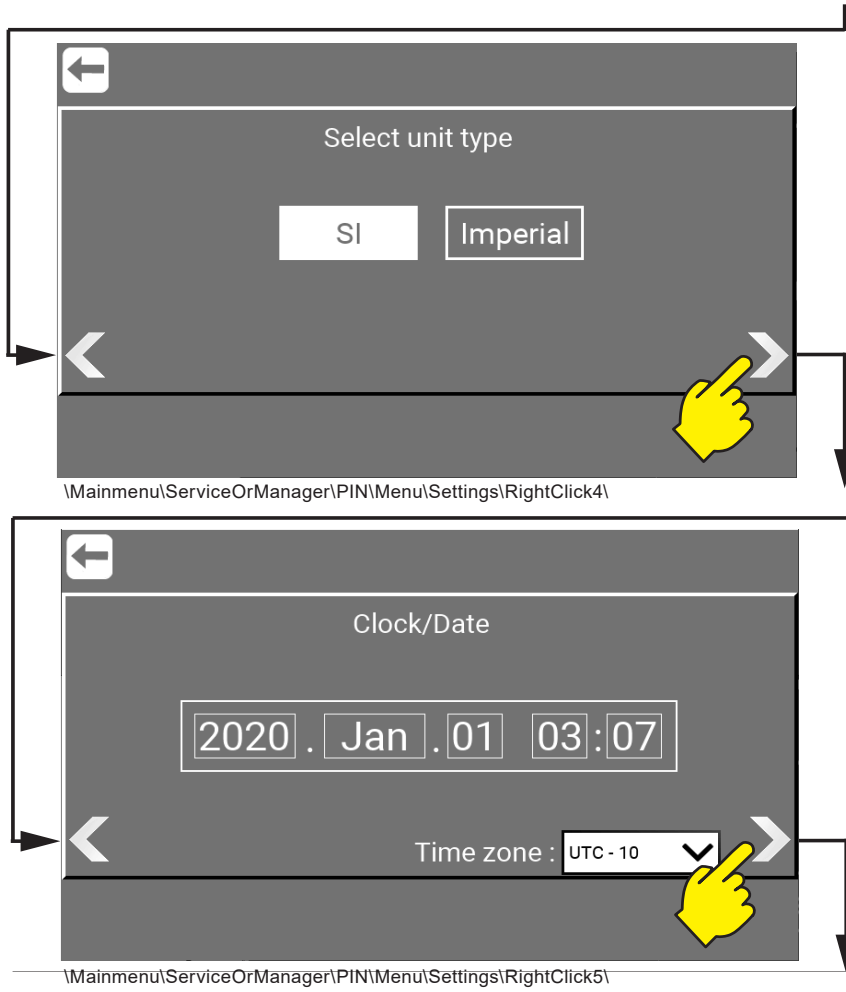

8.2.10. Clock/Date

Select time for the screen saver. And choose if the screen saver should show Logo or Clock when activated.

8.2.11. Time zone

Select the units timezone.

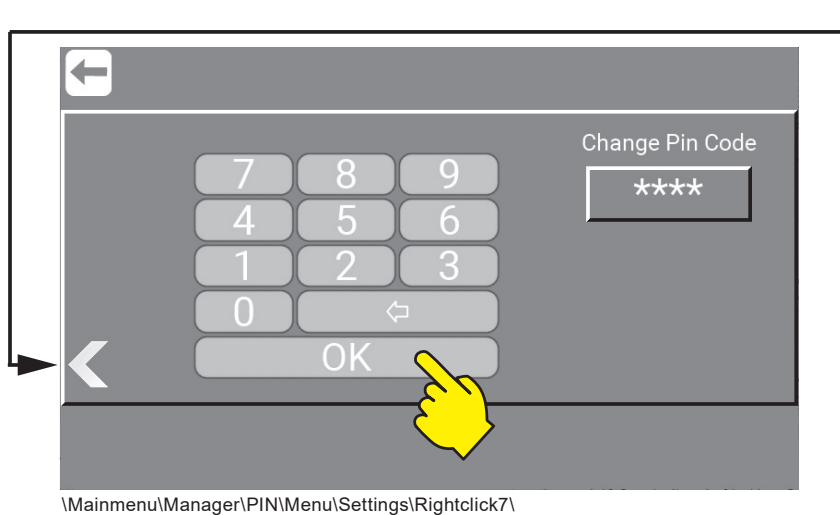

8.2.12. PIN Code change for manager (Only as Manager)

The "Manager" button in mainmenu is password protected. It cannot be disabled, but it can be changed here by Manager. Enter the new code and confirm with OK. (Default code : 6802)

Note : PIN Code change for Manager is the last subscreen in Settings for Manager. But as Service there are 3 more subscreens as here below.

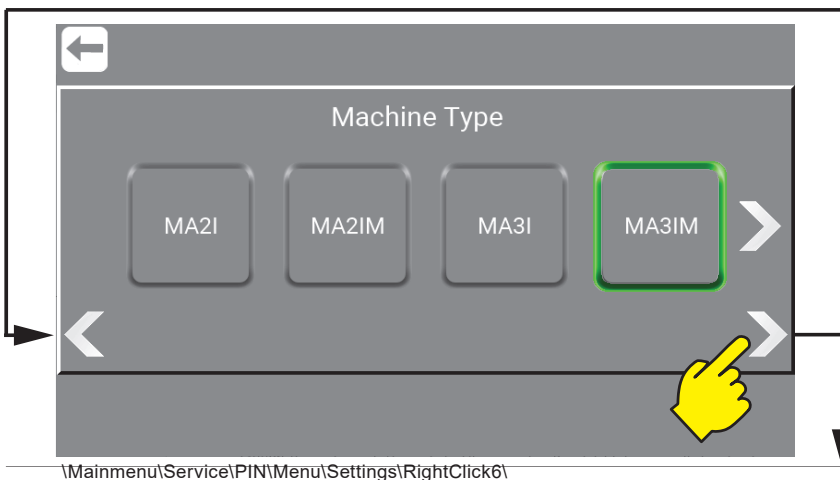

See more "4. Password protection setup / change" on page 12

8.2.13. Change of Machine type (Only as Service)

Machine type are defined on the identification plate. More about this in the Direction for Use manual.

M/S: M: Mainstation / S: Satellite
A: Automatic
2/3: Number of products
I: I/O Moduls
M: Manual Block

The selected machine type is highlighted with a green frame. As Service it can be changed here. Press the right arrow to see all the machine types available.

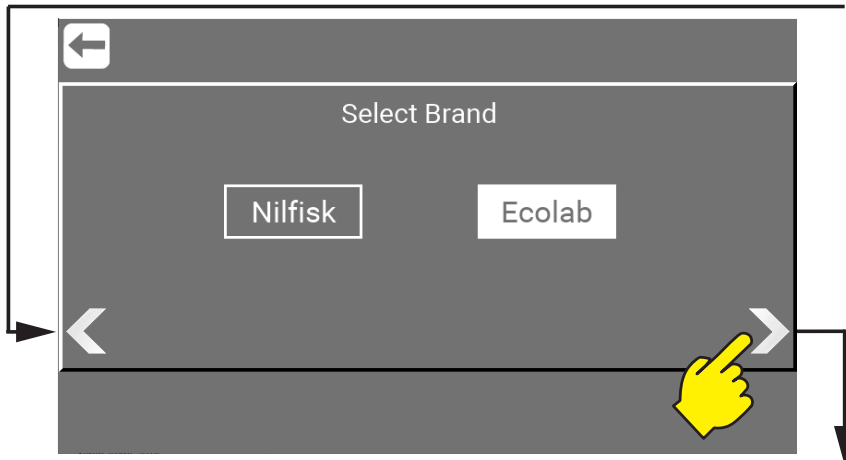

8.2.14. Select Brand (Only as Service)

As "Service" it is possible to switch the graphic user interface (GUI) between Nilfisk or Ecolab.

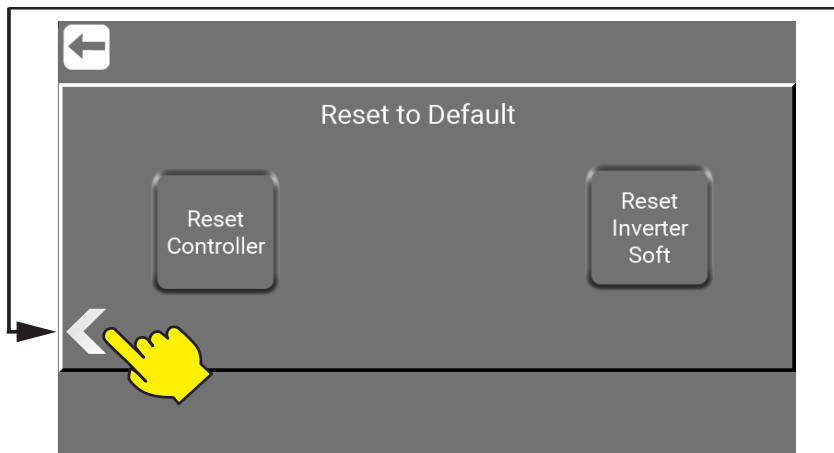

\Service\Menu\Foamatic\

8.2.15. Reset to Default (Only as Service)

Reset Controller is only for reset of the Multicontroller.

Reset Inverter Soft is only for reset of the Inverter Software.

Alle customer settings will be lost when a reset is completed, so when pressing one of these buttons a warning will appere and ask you to confirm this reset.

8.3. Port Function / as Service

The Port function area is for working with Inputs and Outputs.

Press the "Port Functions" button.

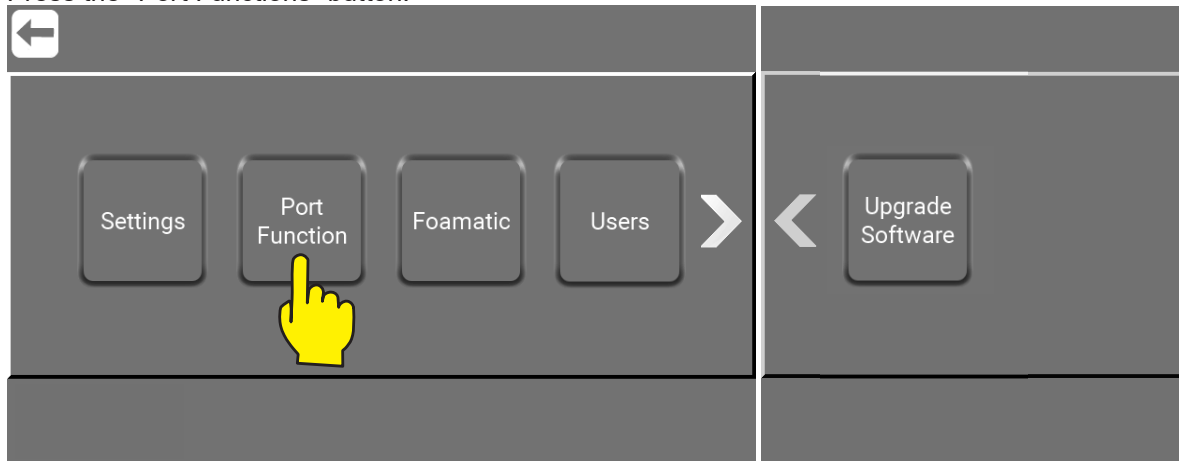

\\Mainmenu\Service\PIN\Menu\

For more go to "8.8.4. What is Inputs, Inputs available and their functionality" on page 43 and see more. And "8.8.6. What is Outputs, Outputs available and their functionality" on page 46 and see more.

8.4. Foamatic / as Service

The Foamatic area is where the automatic system can be set and changed. Things like Wash Programs, Wash Steps, Areas, Adding additional IO Modules etc.

Press the "Foamatic" button.

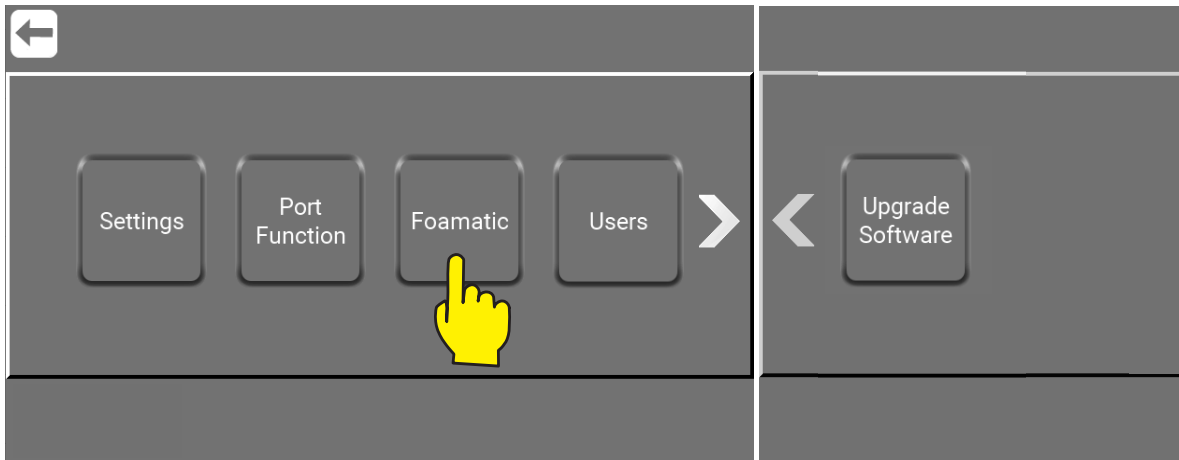

\Mainmenu\Service\PIN\Menu\

Foamatic Subscreen

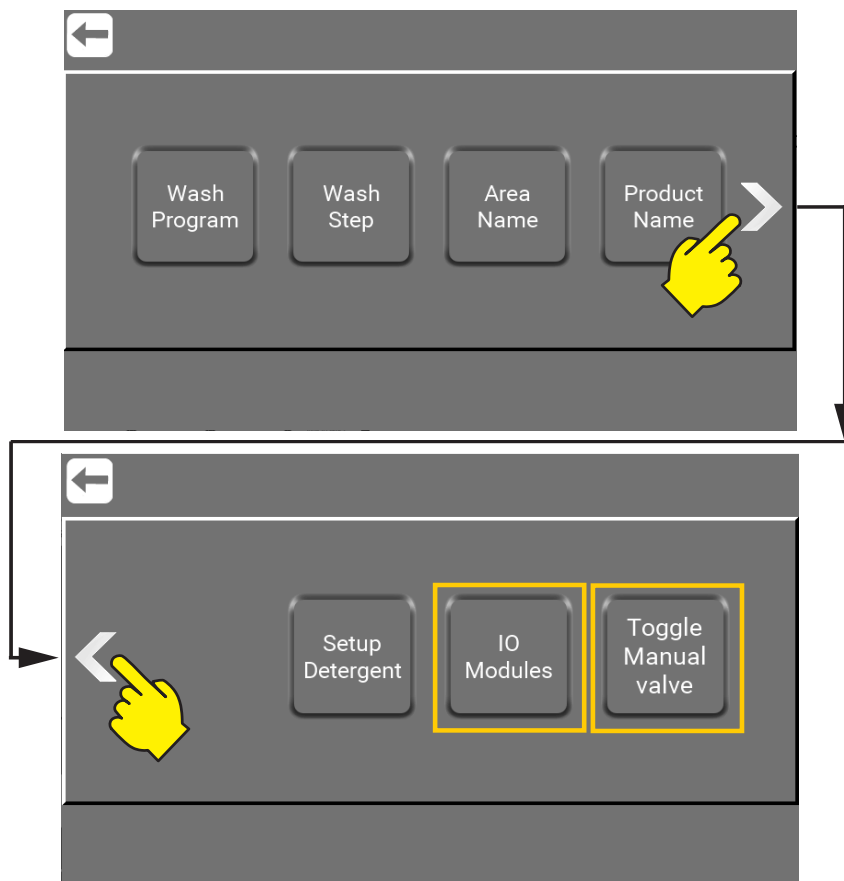

\Service\Menu\Foamatic\

Note : "IO-Module" and "Toggle Manual" Valve is only available as "Service", not as "Manager"

8.4.1. Wash Program / as Service

Wash programs are used for cleaning; it consists of wash steps, up to 100 steps in each program. This menu describes how to make, edit and delete wash programs. The unit can hold up to 16 wash programs. For more and how to use it go to "8.9.15. Wash Programs" on page 61

8.4.1.1. Set Program Pause Time

Set the time the unit can be in pause before it automatically will change from pause to stop, unless it is activated again. Minimum 1 minute, maximum 10 minutes.

Press "Wash Program"

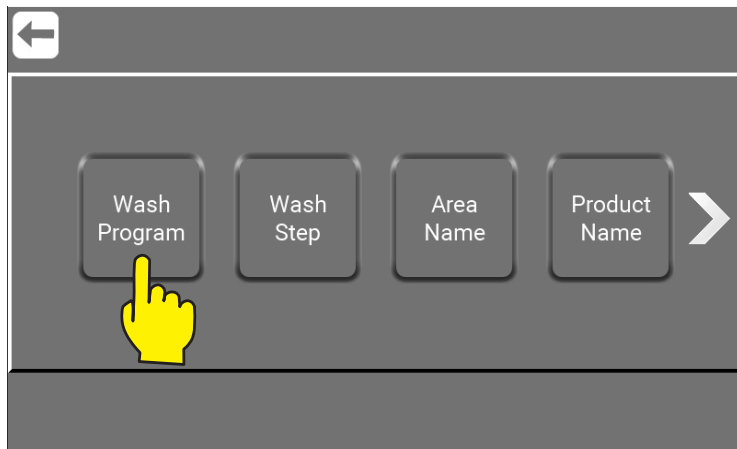

\\Mainmenu\Service\PIN\Menu\Foamatic\...

Press the "Wash program" button.

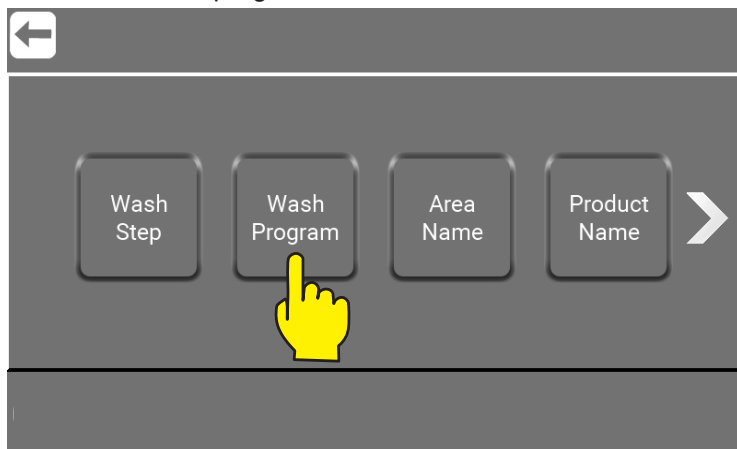

\\Mainmenu\Service\PIN\Menu\Foamatic\...

Press the "Program Pause Time" button.

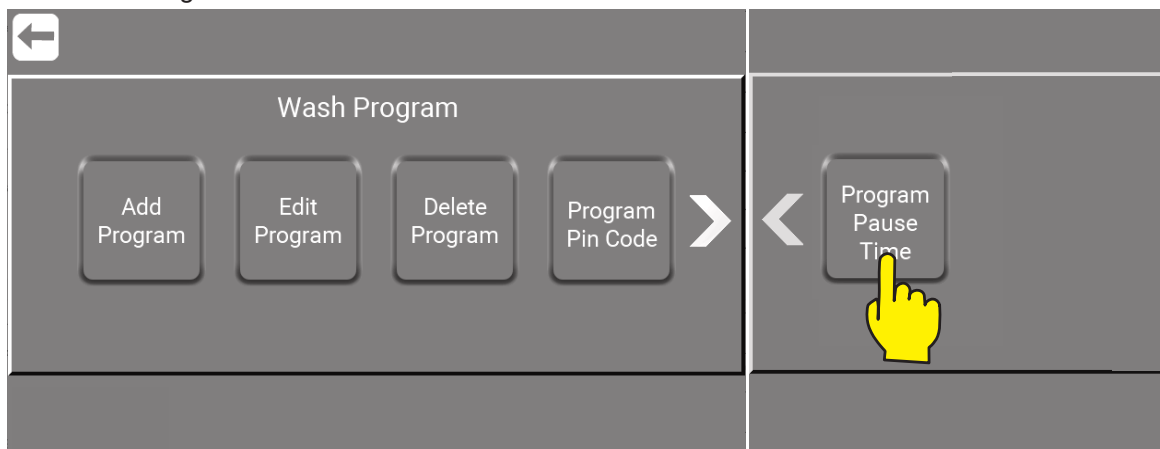

\\Mainmenu\Service\PIN\Menu\Foamatic\WashProgram\...

Set the time the unit can be in pause before it automatically will change from pause until stop, unless it is activated again. Minimum one minute, maximum 10 minutes.

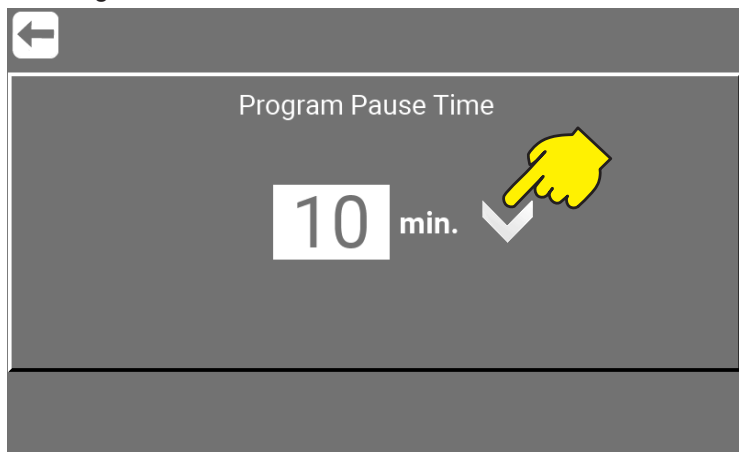

\\Mainmenu\Service\PIN\Menu\Foamatic\WashProgram\ProgramPauseTime\...

8.4.2. Wash Step / as Service

How to use it and more go to "8.9.14. Wash steps" on page 55

8.4.3. Area Names / as Service

How to use it and more go to "8.8.3. Area Name - Setup" on page 42

8.4.4. Product Names / as Service

Area to change names of products connected to the unit.
Press the required product e.g. "Product A" button.

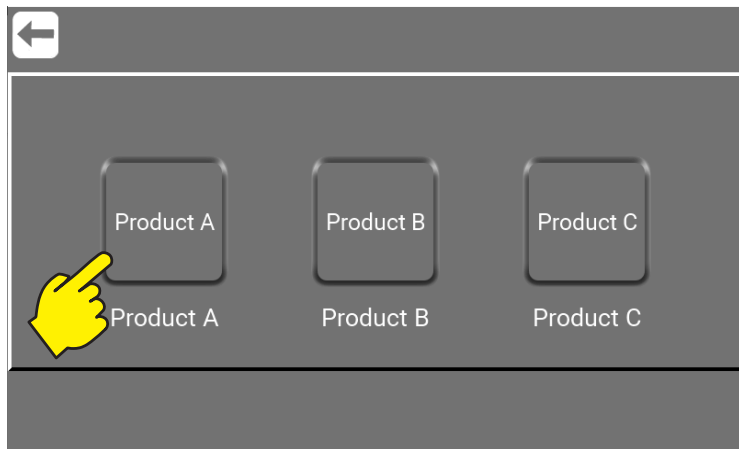

\\Mainmenu\ManagerOrService\PIN\Menu\Foamatic\ProductName\

Enter new name of product and Confirm.



\\Mainmenu\ManagerOrService\PIN\Menu\Foamatic\ProductName\ProductA\

8.4.5. Setup Detergent / as Service

Press the required e.g. "Spray" button.

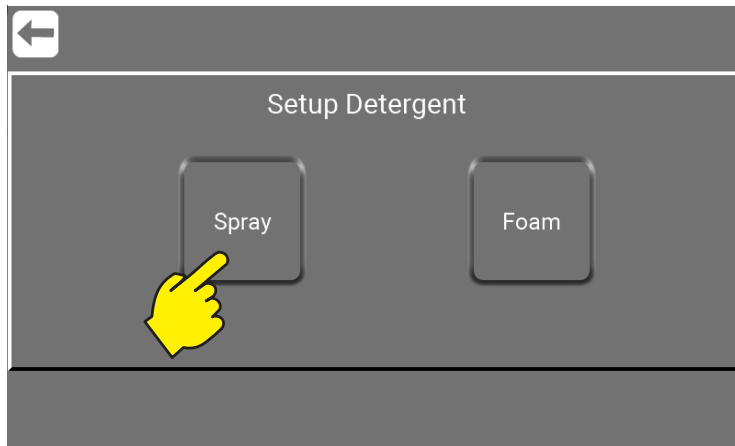

\\Mainmenu\ManagerOrService\PIN\Menu\Foamatic\SetupDetergent\

Spray : is for controlling/adjusting concentration of chemistry in water.

Foam : is for controlling foam quality.

Press the required product e.g. "Product A" button.

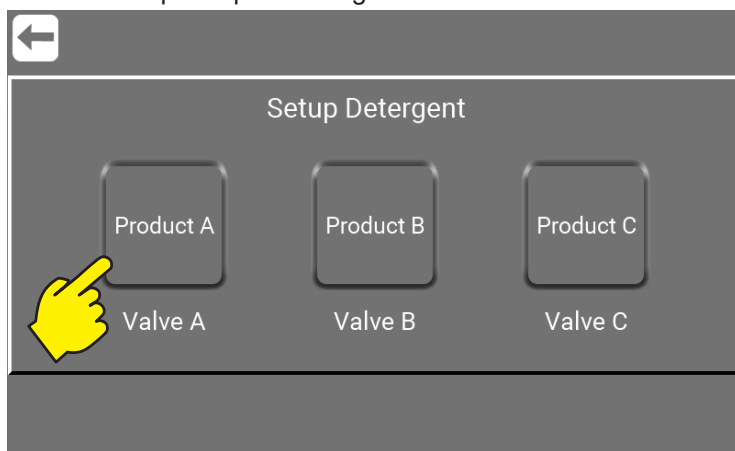

\\Mainmenu\ManagerOrService\PIN\Menu\Foamatic\ProductName\ProductA\

8.4.6. Flow Detect

The time for the unit to detect flow in a washprogram, if valves that creates flow are opened, if no flow is detected an error will occur.

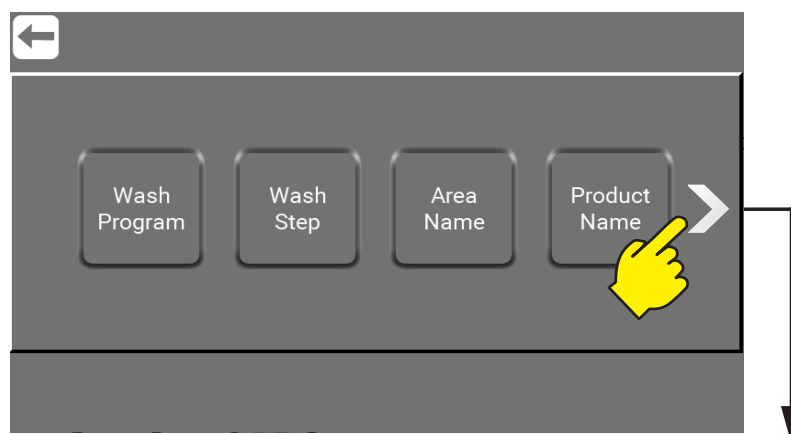

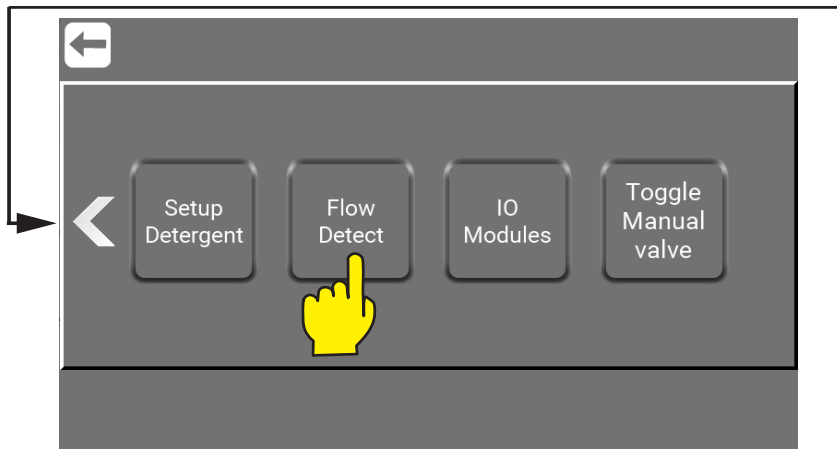

\\Mainmenu\Service\PIN\Menu\Foamatic\RightClick2\...

1. Press to disable "flow detection" or to enable when disabled.
2. Set the required "Detection Delay" by pressing arrow up or down.
Min. value 3 sec., max. 30 sec. (mainstation only).

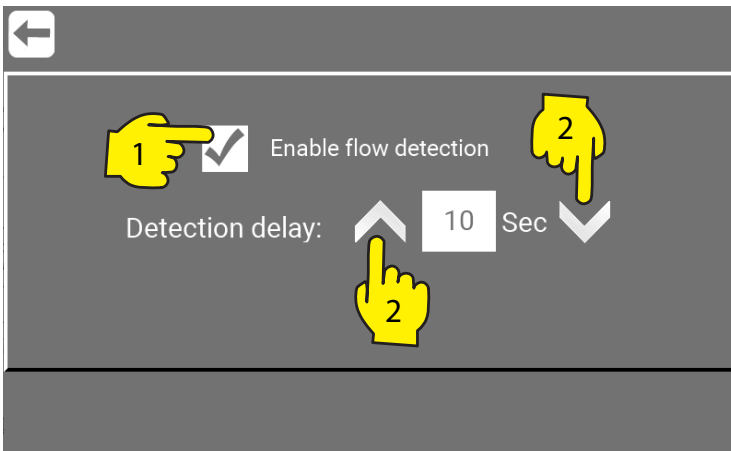

\\Mainmenu\ManagerOrService\PIN\Menu\Foamatic\RightClick2\FlowDetect\...

Error that occurs when running a program and no flow is detected. And "Flow detection" is enabled.

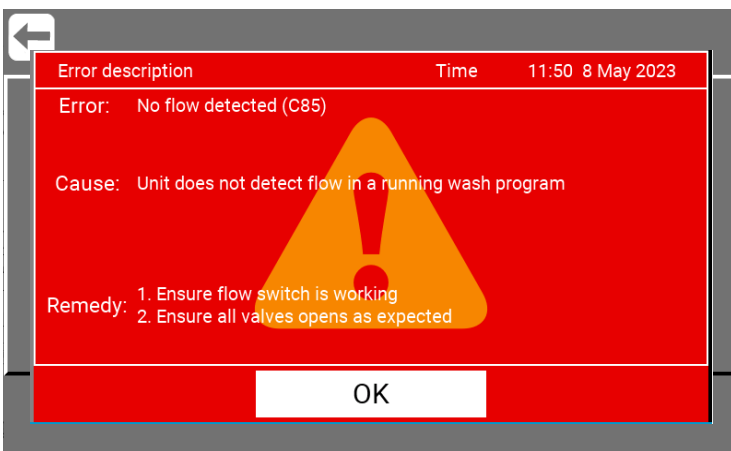

\\Mainmenu\ManagerOrService\PIN\Menu\Foamatic\RightClick2\FlowDetect\...

8.4.7. IO Modules / as Service

Go to "8.8.2. Add external I/O Modules (Accessory / Add on)" on page 41

8.4.8. Toggle Manual Valve / as Service

The "Toggle Manual Valve" button is for adjusting the flowswitch located on the manual outlet. (Button is only available on units with manual outlet) The flowswitch is adjusted from the factory, so this is only for service situations afterwards where adjustment is necessary. (Only available on units with manual outlet).

8.4.9.9. Adjust the flowswitch on manual outlet

Press the "Toggle Manual Valve" and the button will light up green. Valve will open but not start the machine.

Note : "Toggle Manual Valve" button are only available as "Service", not as "Manager"

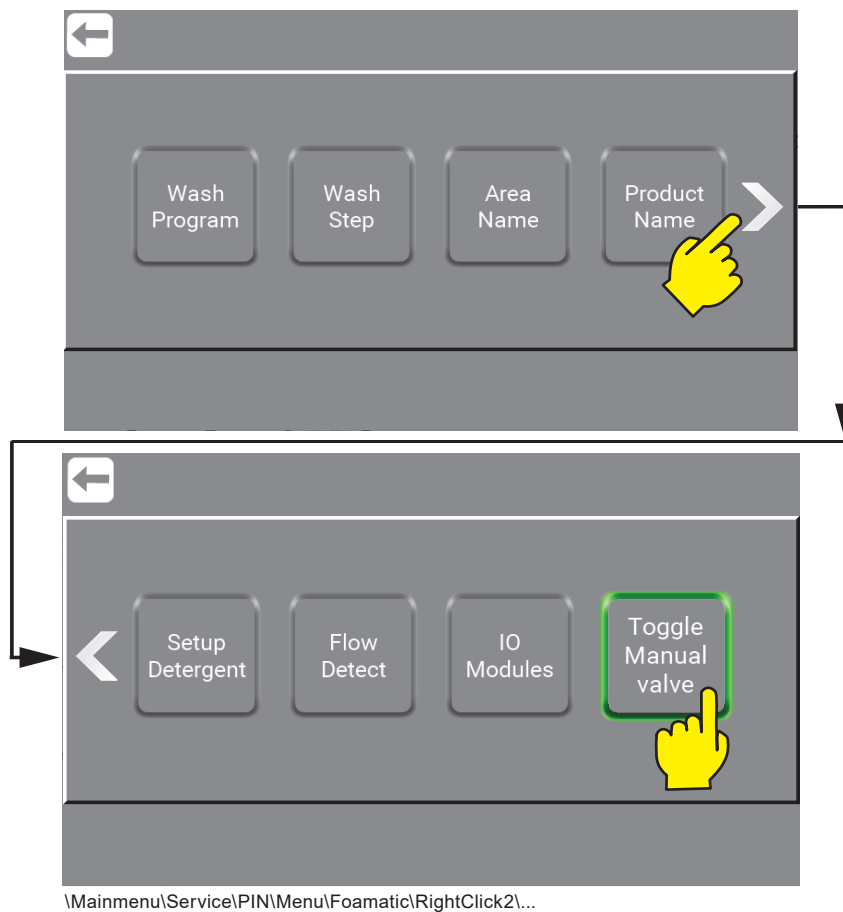

8.5. Users / as Service

The Users area is where Service can make changes regarding the "Manager" like password, name etc. For more go to "4.4. Change PIN Code for Manager / as Service" on page 13

8.6. Upgrade Software / as Service

For instructions for how to Upgrade Software go to "11. Software update" on page 76

8.7. Manual / as Service

The Services test mode (Manual) is a place to test if the unit's setup is as required. Service has access to the settings button in all subscreen in here.

Press the "Manual" button.

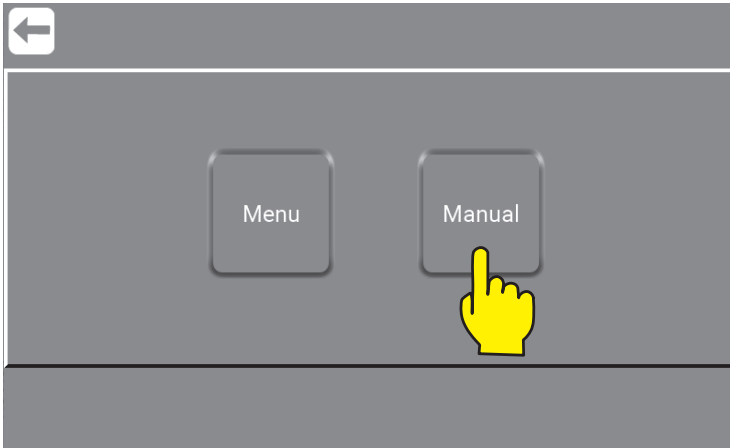

\\Mainmenu\ManagerOrService\PIN\

Press the required preset pressure button to activate the unit.
Manual cleaning is now active and will start running when there is flow.

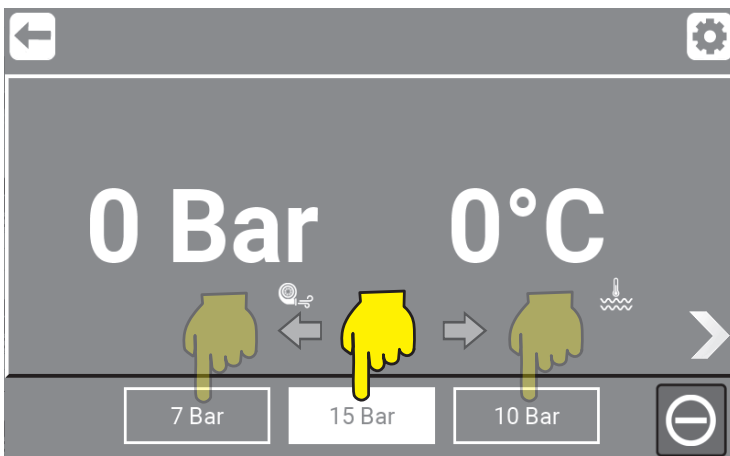

\\Mainmenu\ManagerOrService\PIN\Manual\

8.7.1. Manual mode graphic overview

When pressing "Right Arrow" you will find a graphic overview with data from the running unit. In here Service- and Manager can check data and make changes by pressing "Settings" anytime wanted.

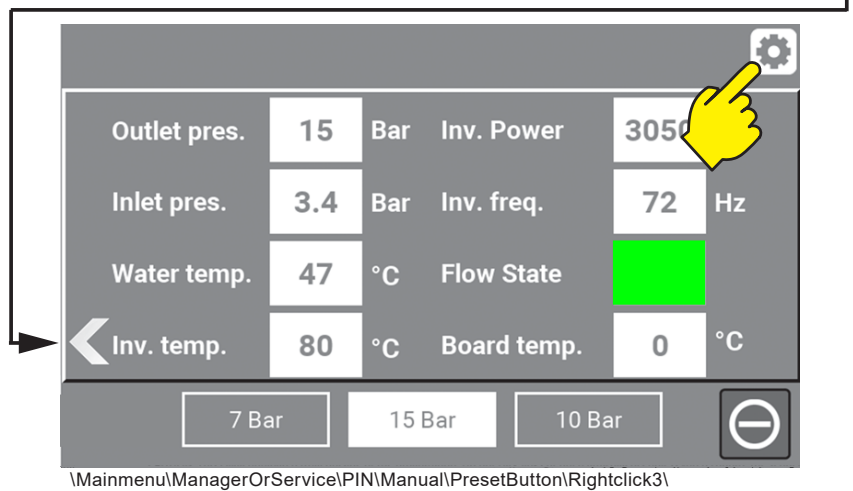
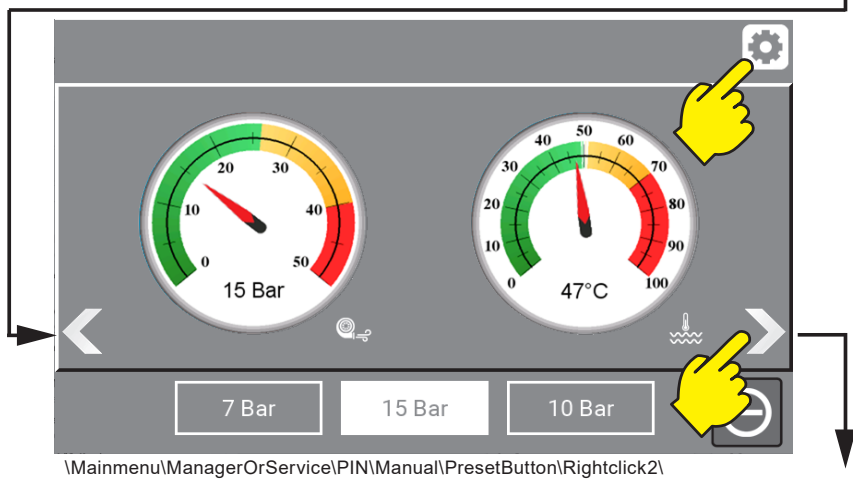
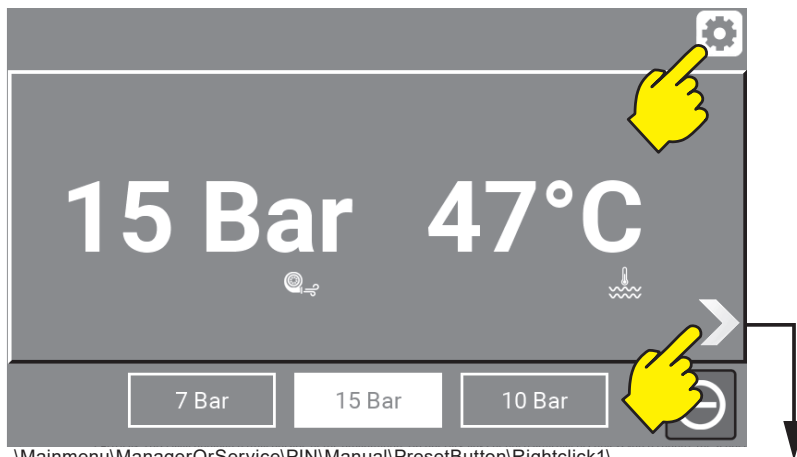

8.8. Quick guide setup - Step by Step / as Service

Below is a quick guide for "Service" to setup this new foamatic unit.

8.8.1. Select Machine Type

Press the right arrow to see all the machine types available.

Go to \Mainmenu\Service\PIN\Menu\Settings\RightClick6\

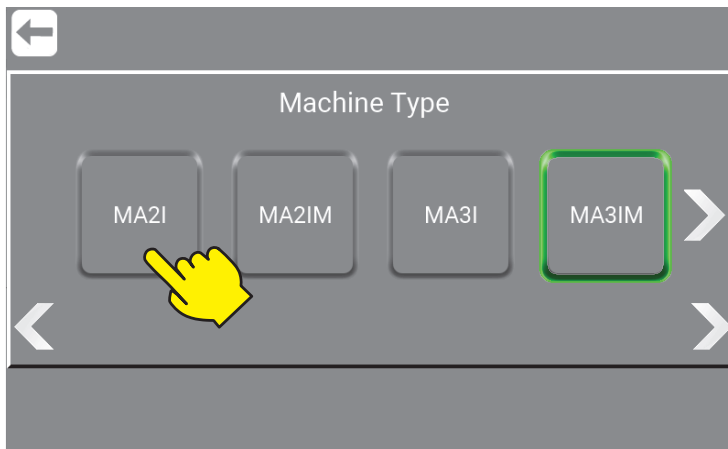

\Mainmenu\Service\PIN\Menu\Settings\RightClick6\

Machine type are defined on the identification plate.

More about this in the Direction for Use manual 110009190 / 110009193.

M/S: M: Mainstation / S: Satellite
A: Automatic
2/3: Number of products
I: I/O Moduls
M: Manual Block

The selected machine type is highlighed with a green frame.

8.8.2. Add external I/O Modules (Accessory / Add on)

If external I/O Modules have been purchased, they need connection to the multicontroller.

How to connect go to \Mainmenu\Service\PIN\Menu\Foamatic\Extra IO Modules\

Press the "Ekstra IO Module" button.

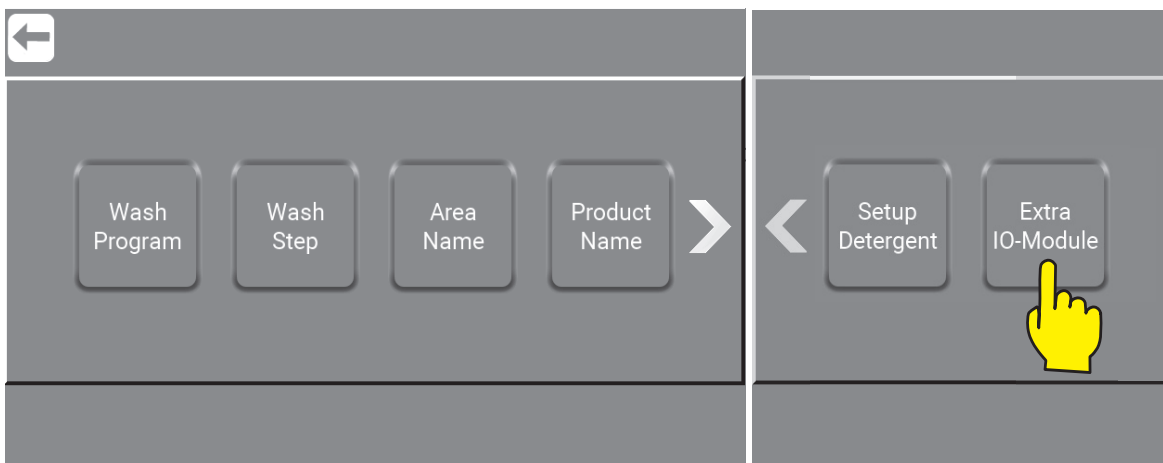

\Mainmenu\Service\PIN\Menu\Foamatic\

Press the arrow up to add 1 or 2 external I/O Moduls.
And then Confirm the number of modules.

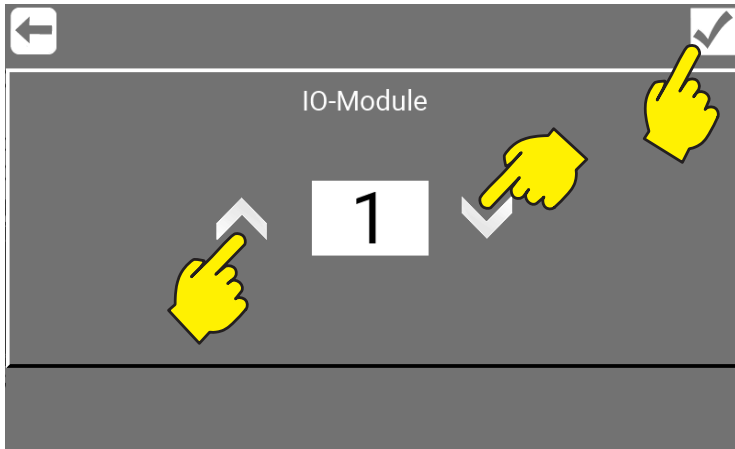

\Mainmenu\Service\PIN\Menu\Foamatic\ExtralOModule\

8.8.3. Area Name - Setup

Naming, the different areas connected to the unit. (Min. 1 Max. 32 Areas).

Go to \Mainmenu\Service\PIN\Menu\Foamatic\AreaName\

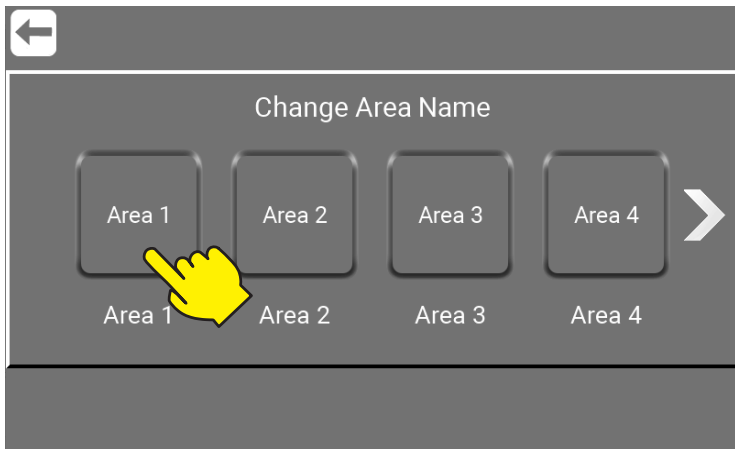

\Mainmenu\Service\PIN\Menu\Foamatic\AreaName\

Enter the new name e.g. "Production 1" and Confirm. (Character limit 1/16).



\Mainmenu\Service\PIN\Menu\Foamatic\AreaName\

8.8.4. What is Inputs, Inputs available and their functionality

Input signals are in general electrical signals given to the unit to achieve a given behavior, for example, start wash program, warning or error. For more about the different kinds of inputs and how to make them follow the next steps. Maximum number of Input is 48 (Standard 1 x IO and 2 x IO modules added).(Assesorys)

8.8.4.1. Start Program

The Wash Program attached to this function will start when input is activated.

8.8.4.2. Stop Program

When this input function is activated, the Wash Program(s) attached to this function will stop.

8.8.4.3. Pause Program

When this input function is activated, the Wash Program(s) attached to this function will be paused. If wash program is not started again within the pause timeout, the wash program will stop.

8.8.4.4. Release Program

When this input function is activated, This signal must be there for the wash program to start, it can be removed again after the start without the wash program stopping.

8.8.4.5. Release Hold Program

If this input is activated, The wash program(s) can only start if the input is active. If input signal is removed during wash program run, the wash program will stop.

8.8.4.6. Lance Empty

Makes it possible for the Multicontroller to make an error when the product can of a specific product is empty. This error will prevent the unit from being started. Input can be either Product A, B, C or Global. Global means that the it doesn't pay attention to which can is empty. Must be connected to a level switch.

8.8.4.7. Lance Low

Warning that indicates that the level in the product can of a specific product is getting critical. If this is activated the program running, will run to the end, but a new program cannot be started. Input can be either Product A, B, C or Global. Global means that the it doesn't pay attention to which can is empty. Must be connected to a level switch.

8.8.4.8. External Error

Function to let an external source generate an error, for example a booster error signal.

8.8.4.9. External Activation

Input if used in a wash step, will hold the wash step at the current action, and wait for this input to be activated before continuing, this signal is related to Zone Valves.

8.8.4.10. Release

If this input is activated, it is a release for the entire machine. This signal is required in order for the machine to run, regardless of whether it is a wash program or manual. If removed it stops the machine.

8.8.4.11. Blocked

If this input is activated, This is a block for the entire machine. This signal is required in order for the machine to run, regardless of whether it is a wash program or manual. If removed it tops the machine.

8.8.4.12. Safety active

Could be used to indicate a safety error, coming from an external component.

8.8.5. Add Input - How to add Input signals

To add functionality to the Multicontroller, inputs are needed.

Go to \Mainmenu\ManagerOrService\PIN\Menu\PortFunction\

Press the "Add Input" button.

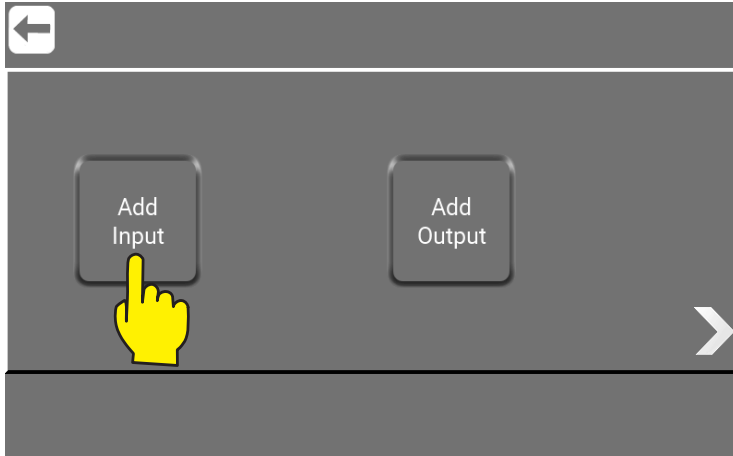

\Mainmenu\ManagerOrService\PIN\Menu\PortFunctions\...

Press the input required e.g. "Lance Empty" button.

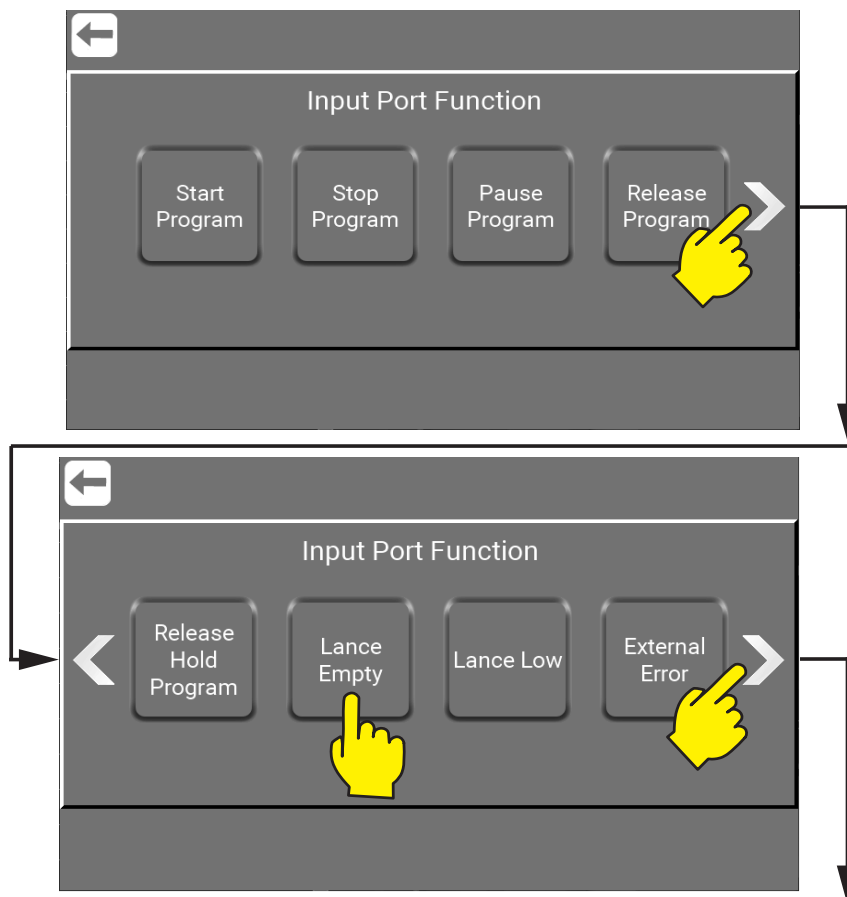

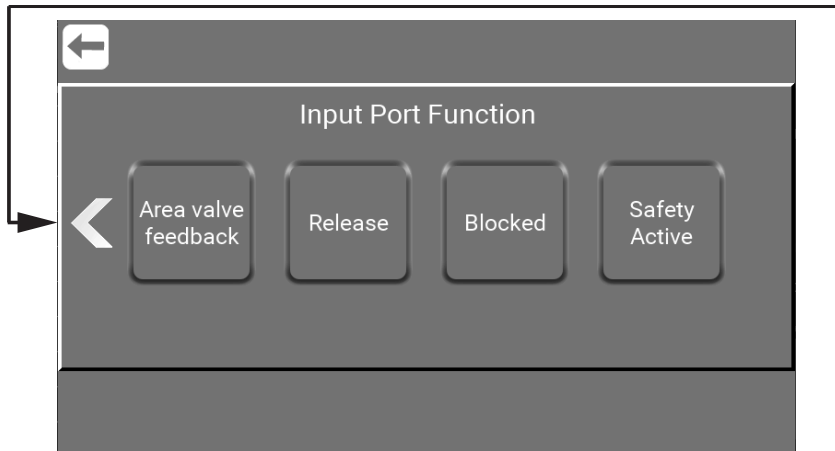

\\Mainmenu\ManagerOrService\PIN\Menu\PortFunctions\AddInput\...

Note : For a complete list of all inputs as well as how to use the setup functions - go to :
"8.9. Show I/O's connected or in use" on page 50

Press the function e.g. "Product A" button.

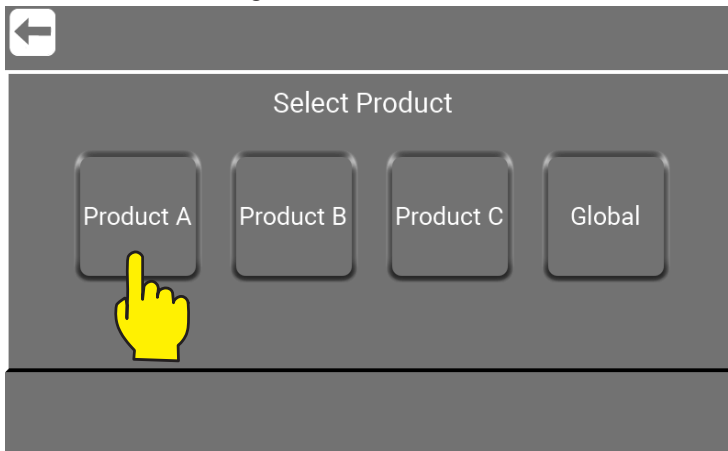

\\Mainmenu\ManagerOrService\PIN\Menu\PortFunctions\AddInput\LanveEmpty\...

Press the required port for input.

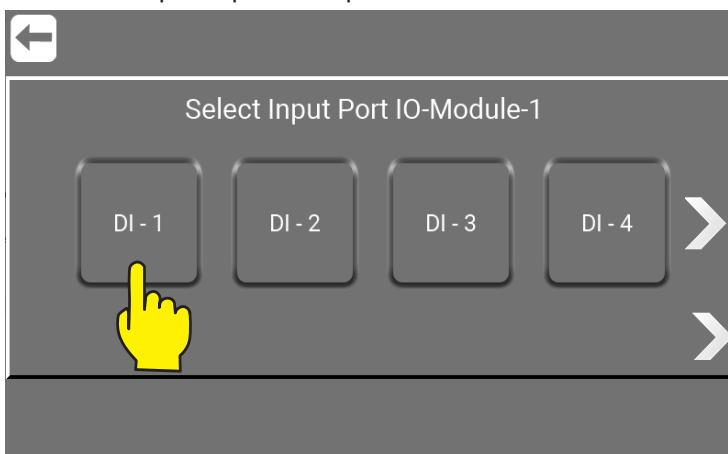

\\Mainmenu\ManagerOrService\PIN\Menu\PortFunctions\AddInput\LanveEmpty\...

Select Input e.g. Port Module -1 by pressing the one of your choice.
("DI - 1" means Direct Input no.1) and outputs ("DO - 1" means Direct Output no.1)

The standard unit has input port 1 and up to 16.

To add more ports 2 external IO Modules can added. (Accessory) Each external module will add editinal 16.

8.8.6. What is Outputs, Outputs available and their functionality

Output signals is used to indicate a given behavior or state, to another control, light tower etc. could for e.g. be system active or program finished.

8.8.6.1. Area Valve

Used for adding Area valves to the installation.

8.8.6.2. Program Active

Output activated when the related wash program(s) is running.

8.8.6.3. Program Finish

Activated when the related wash program(s) is ended.

If a program is stopped when running, this signal will not be activated.

8.8.6.4. System Active

Output activated when the unit is running.

8.8.6.5. System Not Active

Output indicates that the system is Not Active, not running or in standby and no washprogram is active.

8.8.6.6. System Ready

Output indicates that the system is ready to run, no errors is currently pending.

8.8.6.7. Manual Cleaning

Activated when manual cleaning is activated.

8.8.6.8. Running

Activated when pump is running.

8.8.6.9. Not Running

Activated when pump is NOT running

8.8.6.10. Error

Output signal activated when an error is detected in the system, could be low inlet pressure, no communication etc.

8.8.6.11. No Error

Output signal activated when there is no error detected in the system.

8.8.6.12. Stopped

Activated when system is stopped, could be when stop button is pressed.

8.8.6.13. External Release

Ouput activated when the related program is released via the release input function. This to indicate to an external source that the program may/can be started.

8.8.6.14. Hot Water Valve

Hot water valve enables the use of both hot and cold water. To use this function a valve for switching between hot and cold water, must be installed.

8.8.7. Add Output - How to add Output signals.

To add functionality to the Multicontroller, Outputs is needed.

Go to \Mainmenu\ManagerOrService\PIN\Menu\PortFunction\

Press the "Add Output" button.

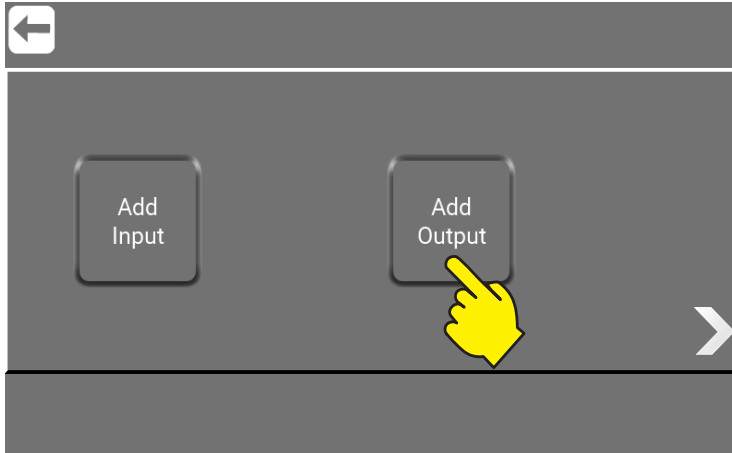

\Mainmenu\ManagerOrService\PIN\Menu\PortFunctions\...

Press the output required e.g. "System Ready" button.

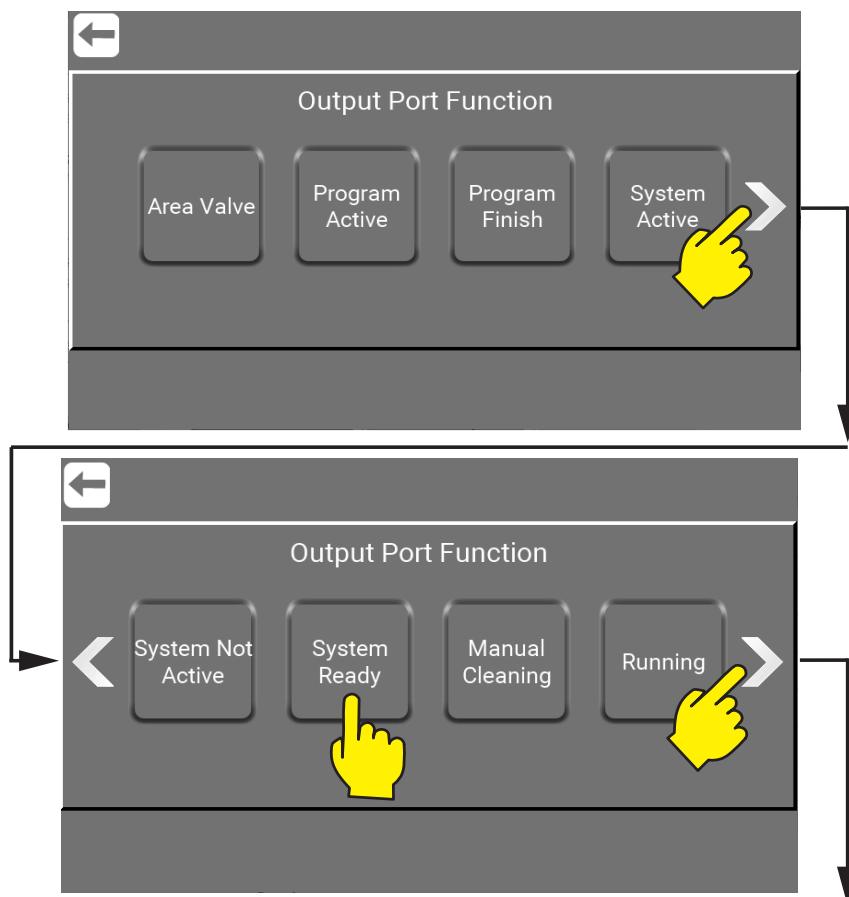

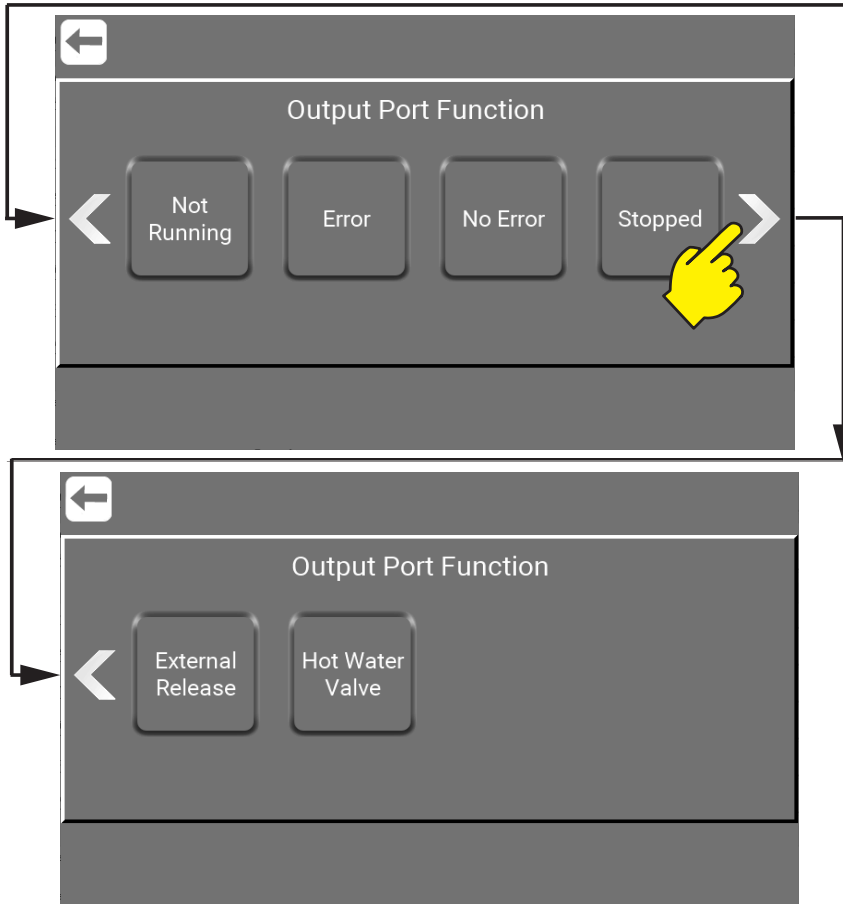

\\Mainmenu\ManagerOrService\PIN\Menu\Foamatic\AddOutput\...

Press the required port for output.

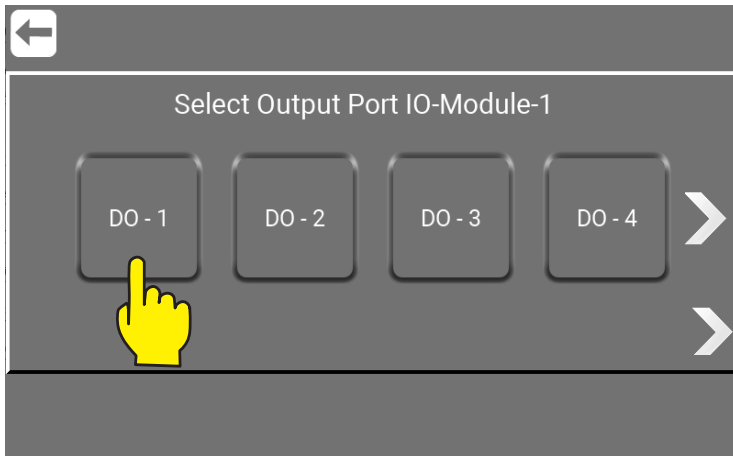

\\Mainmenu\ManagerOrService\PIN\Menu\PortFunctions\AddOutput\...

Select Output e.g. Port Module -1 by pressing the one of your choice.
 ("DI - 1" means Direct Input no.1) and outputs ("DO - 1" means Direct Output no.1)

The standard unit has input port 1 and up to 16.
 To add more ports 2 external IO Modules can added. (Accessory) Each external module will add editinal 16.

8.8.8. Remove Input / Output signals

Press the "Remove Input" or "Remove Output" button.

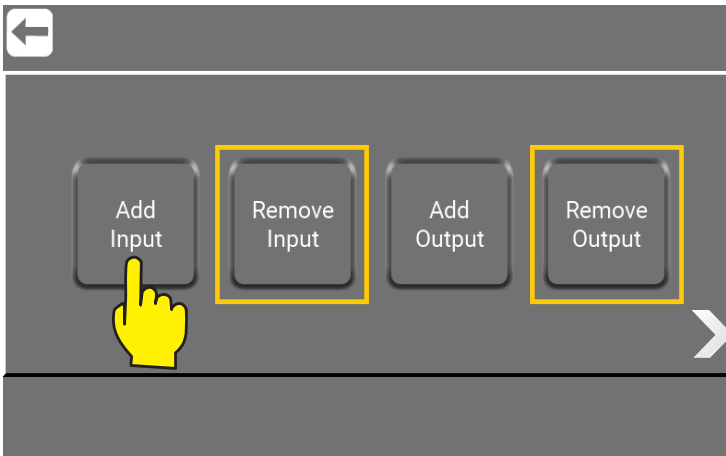

\\Mainmenu\ManagerOrService\PIN\Menu\PortFunctions\...

Note : The "**Remove Input**" and "**Remove Output**" will only be visible when a input or output has been added. (Here marked with yellow boxes.)

Press on the button with the Input / Output to remove.

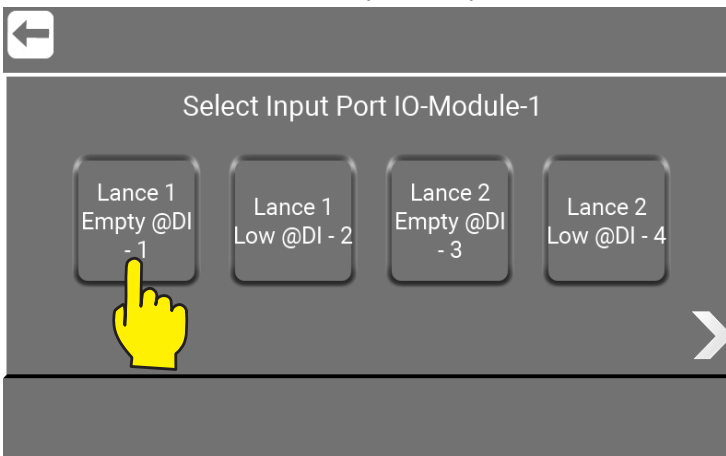

\\Mainmenu\ManagerOrService\PIN\Menu\PortFunctions\RemoveInPutOrOutput\...

8.9. Show I/O's connected or in use

Af graphical overview of which I/Os are connected to the Multicontroller and in use, can be shown by pressing "Right Arrow" in this subscreen \Mainmenu\ManagerOrService\PIN\Menu\PortFunctions\.

To see graphic overview go to :

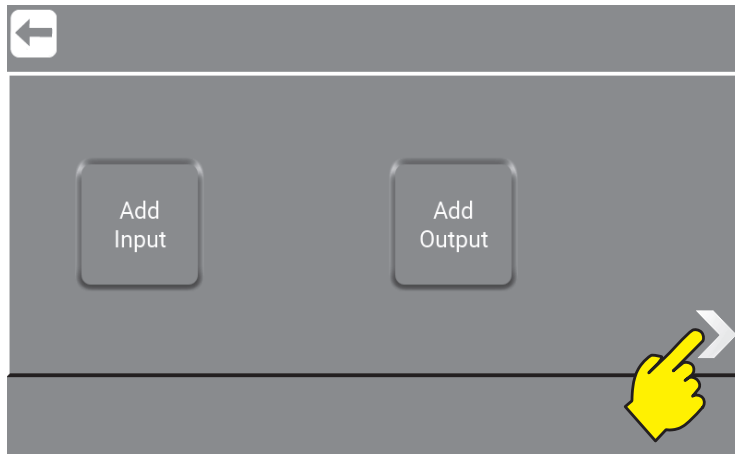

\Mainmenu\ManagerOrService\PIN\Menu\PortFunctions\...

When clicking the "Right Arrow" a sequel of subscreens acure with an overview of inputs ("DI - 1" means Direct Input no.1) and outputs ("DO - 1" means Direct Output no.1) in use or active is marked with a green diode. The subscreens will apperer in this order:

8.9.1.1. Output Port State,

This is the standard outputs.

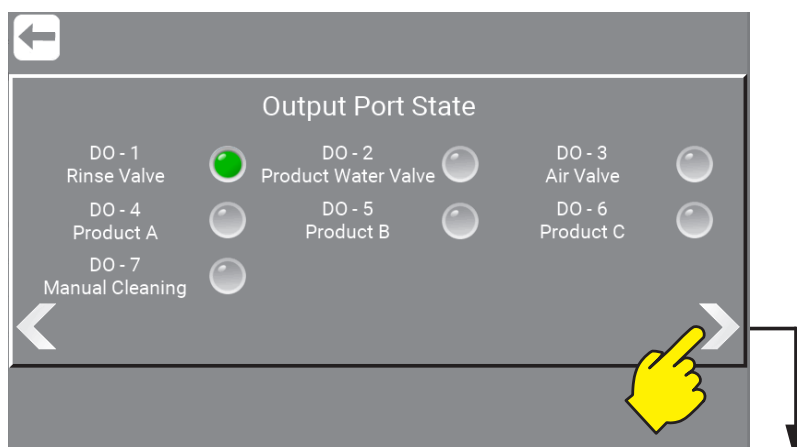

\Mainmenu\ManagerOrService\PIN\Menu\PortFunctions\RightClick1\...

8.9.2.2. IO - Module Input Port State - 1/2,

This is the first 8 inputs (1-8) from the internal IO Module.

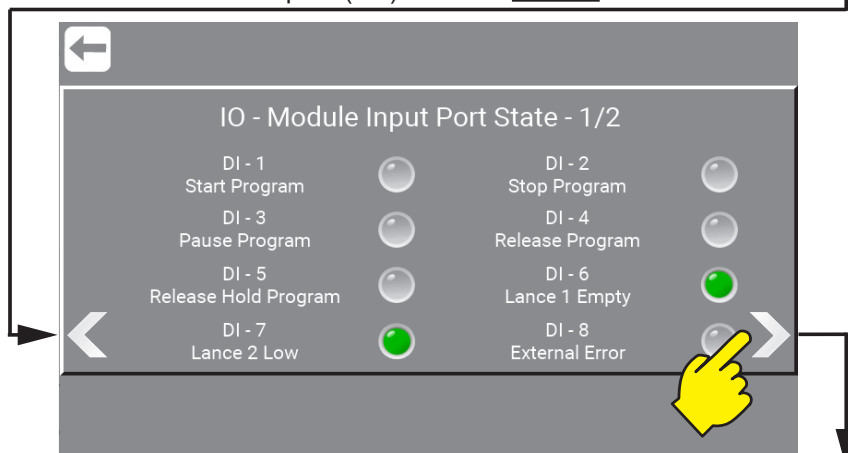

\Mainmenu\ManagerOrService\PIN\Menu\PortFunctions\RightClick2\...

8.9.3.3. IO - Module Input Port State - 2/2,

This is the last 8 inputs (9-16) from the internal IO Module.

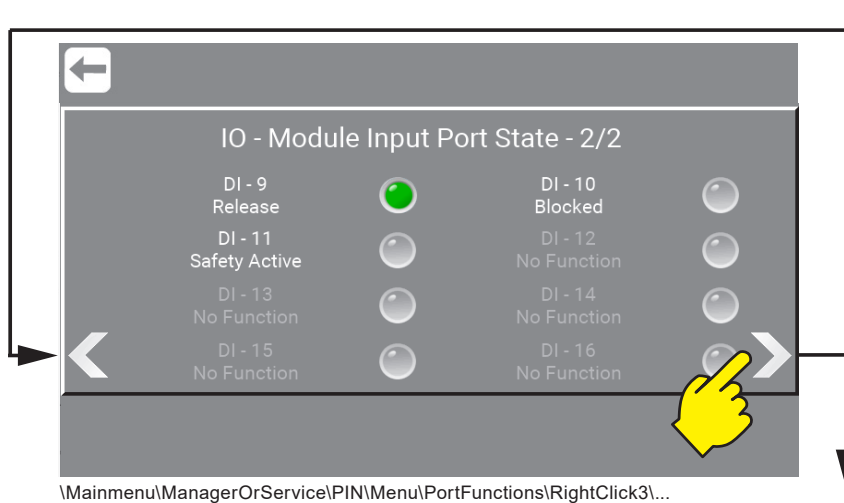

8.9.4.4. IO - Module_2 Input Port State - 1/2,

This is the first 8 inputs (1-8) from the external IO Module.
(Only as Accessory)

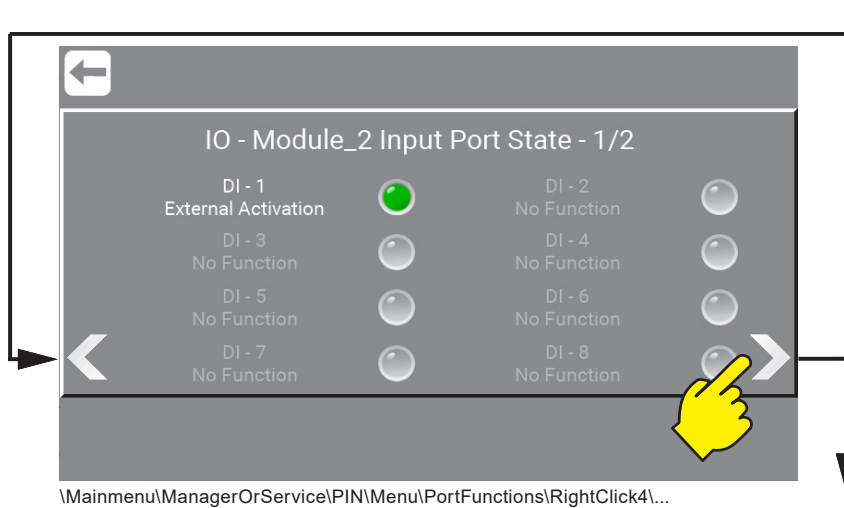

8.9.5.5. IO - Module_2 Input Port State - 2/2,

This is the last 8 inputs (9-16) from the external IO Module.
(Only as Accessory)

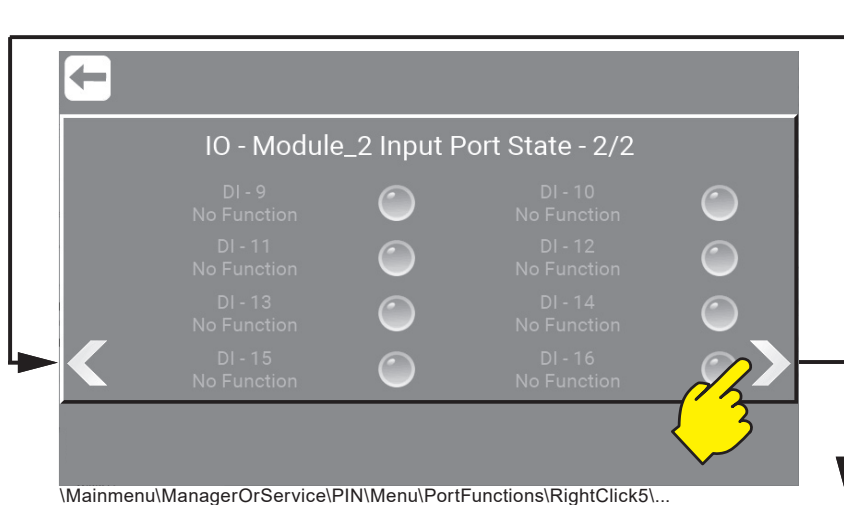

8.9.6.6. IO - Module_3 Input Port State - 1/2,
 This is the first 8 inputs (1-8) from the external IO Module.
 (Only as Accessory)

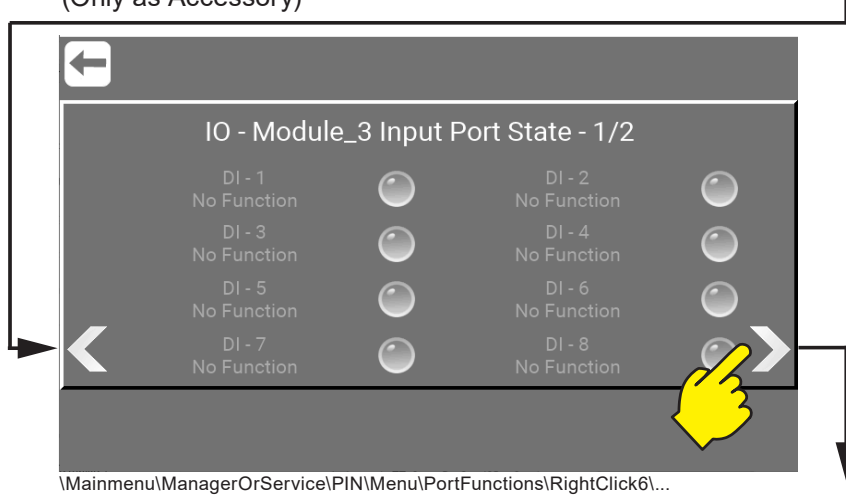

8.9.7.7. IO - Module_3 Input Port State - 2/2,
 This is the last 8 inputs (9-16) from the external IO Module.
 (Only as Accessory)

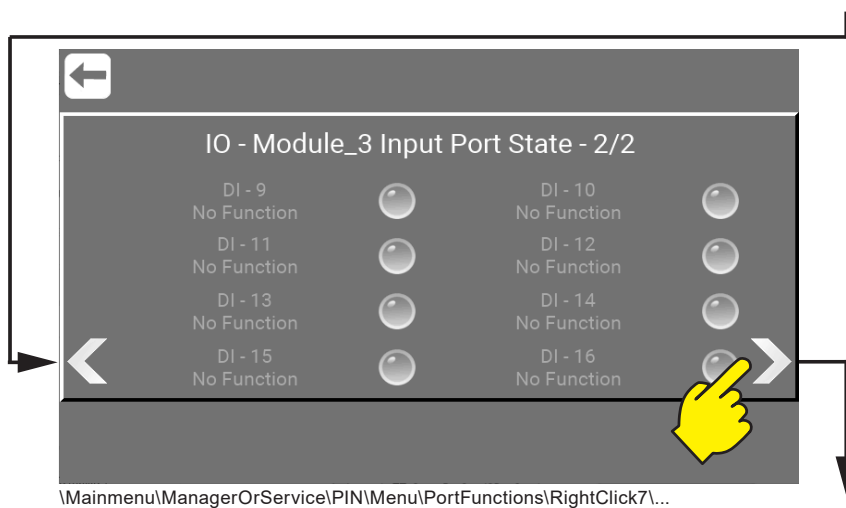

8.9.8.8. IO - Module Output Port State - 1/2,
 This is the first 8 outputs (1-8) from the internal IO Module.
 (Only as Accessory)

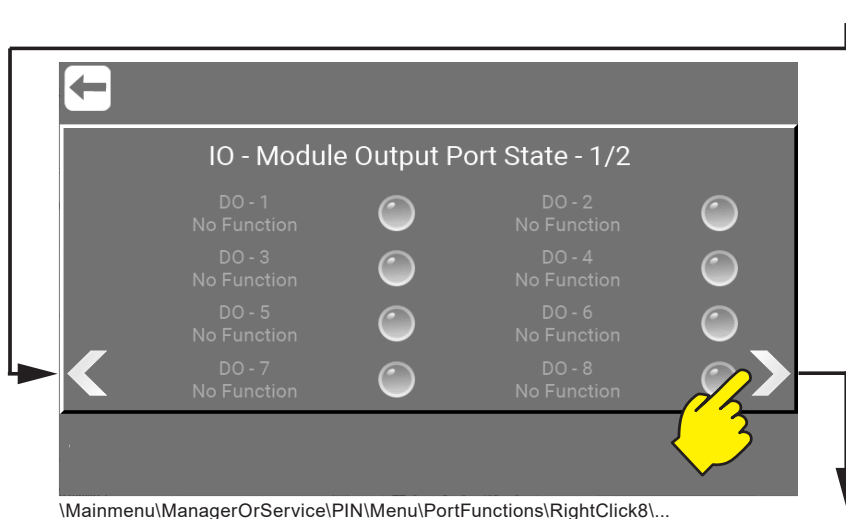

8.9.9.9. IO - Module Output Port State - 2/2,

This is the last 8 outputs (9-16) from the internal IO Module.

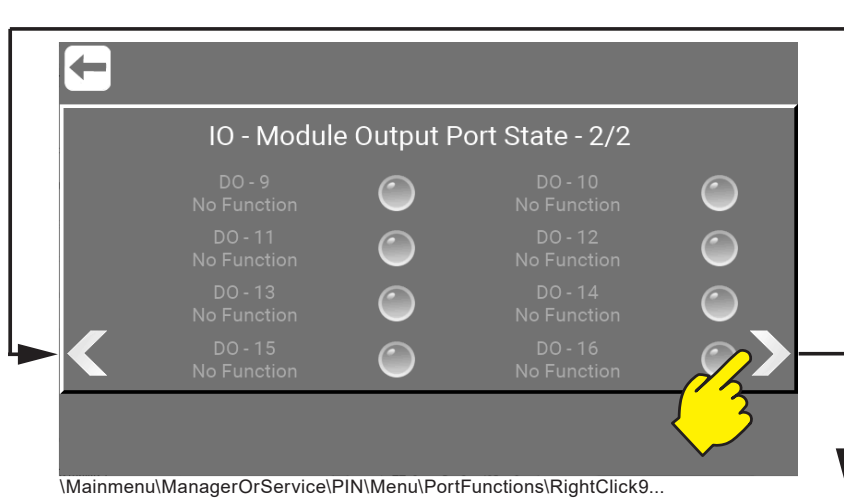

8.9.10.10. IO - Module_2 Output Port State - 1/2,

This is the first 8 outputs (1-8) from the external IO Module.

(Only as Accessory)

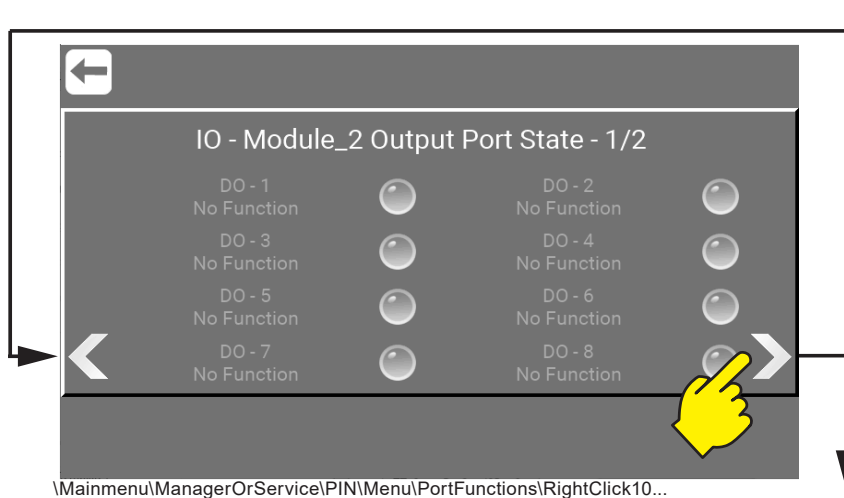

8.9.11.11. IO - Module_2 Output Port State - 2/2,

This is the last 8 outputs (9-16) from the external IO Module.

(Only as Accessory)

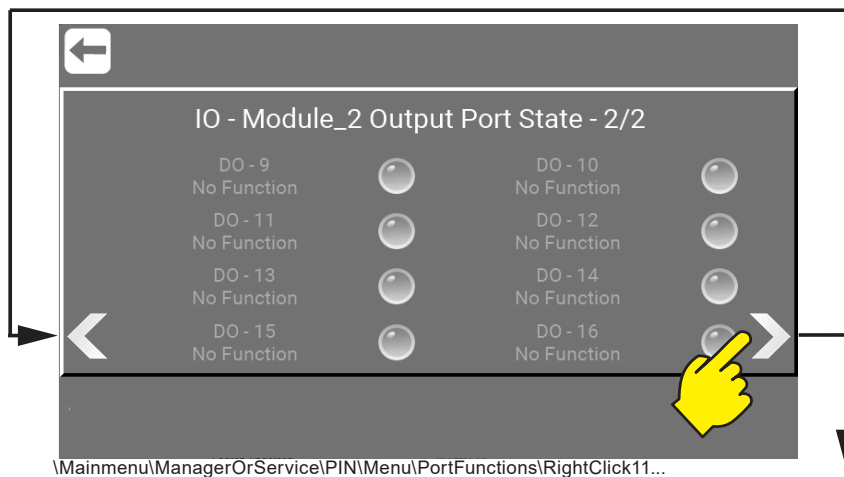

8.9.12.12. IO - Module_3 Output Port State - 1/2,
 This is the first 8 outputs (1-8) from the external IO Module.
 (Only as Accessory)

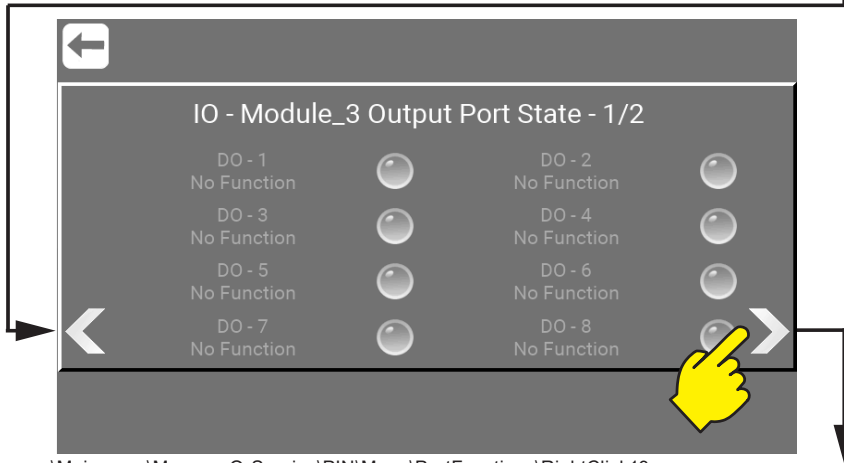

\\Mainmenu\ManagerOrService\PIN\Menu\PortFunctions\RightClick13...

8.9.13.13. IO - Module_3 Output Port State - 2/2,
 This is the last 8 outputs (9-16) from the external IO Module.
 (Only as Accessory)

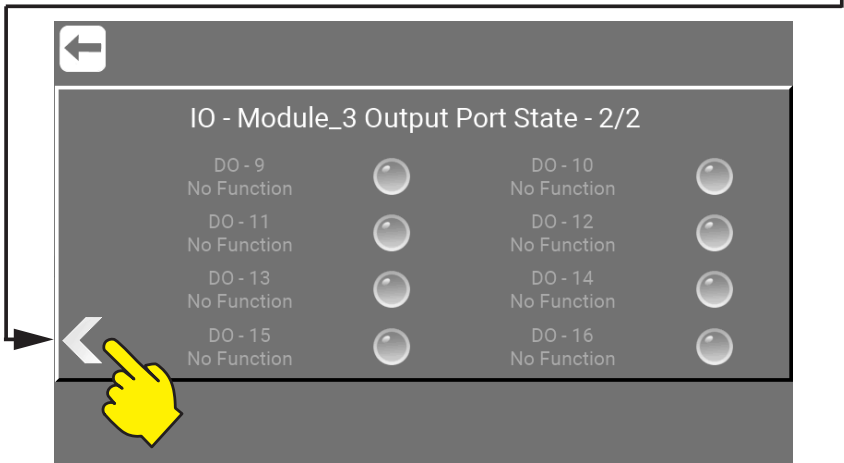

\\Mainmenu\ManagerOrService\PIN\Menu\PortFunctions\RightClick13...

8.9.14. Wash steps

Wash steps are items used to build wash programs. Each wash program is made of a number of wash steps, and each wash step is made of a number of wash actions. This menu is used for building, editing and deleting wash steps. Go to \Mainmenu\ManagerOrService\PIN\Menu\Foamatic\...

8.9.14.1. Add Wash Step

Press the "Wash Step" button.

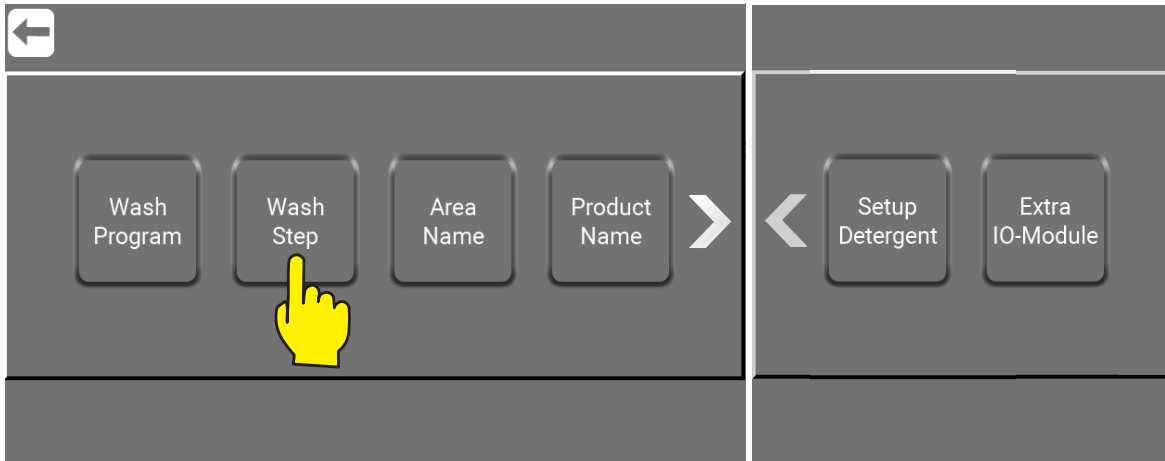

\Mainmenu\ManagerOrService\PIN\Menu\Foamatic\

Press "Add Step".

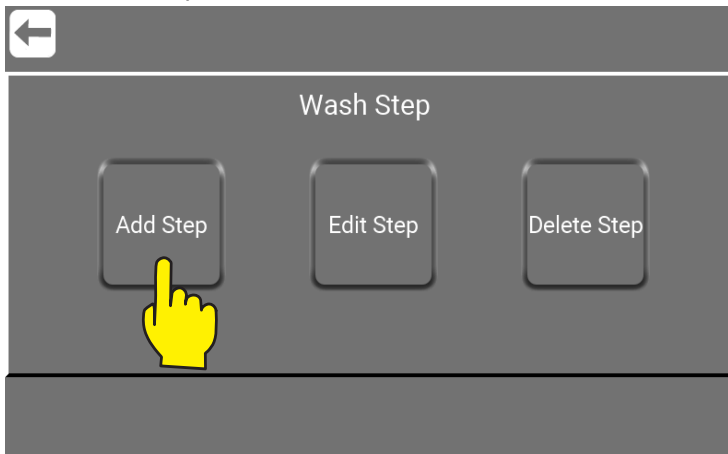

\Mainmenu\ManagerOrService\PIN\Menu\Foamatic\WashStep\

Type in the desired name in for the wash step. Only standard characters and numbers are accepted for the name. It is required for a wash step to have a name, so this field cannot be left blank. The program name can hold a maximum of 16 characters. And then mark if the wash step should use adjustable pressure and/or mix product. When the wash step name, pressure control and mix product is chosen press right arrow.

Press the "Enter Name" field.

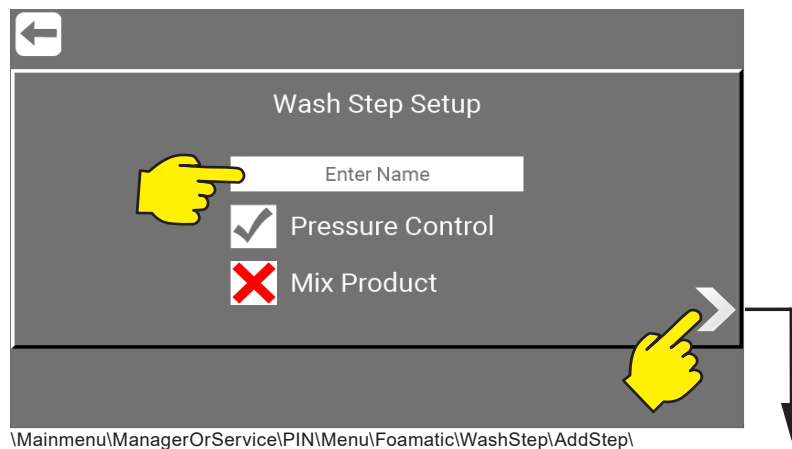

Pressure control: Allows the wash step to use different pressure; the pressure will then be set in the wash program. If the wash step includes an activation/deactivation of product valves, this checkmark has no function. the pressure will always be set to maximum (15 bar).

Mix product: this enables the mix feature of the block, so it will be possible to open two product valves at the same time. Which product valves will be set when adding the wash step to a wash program. Press "Add" to ad a wash step action.

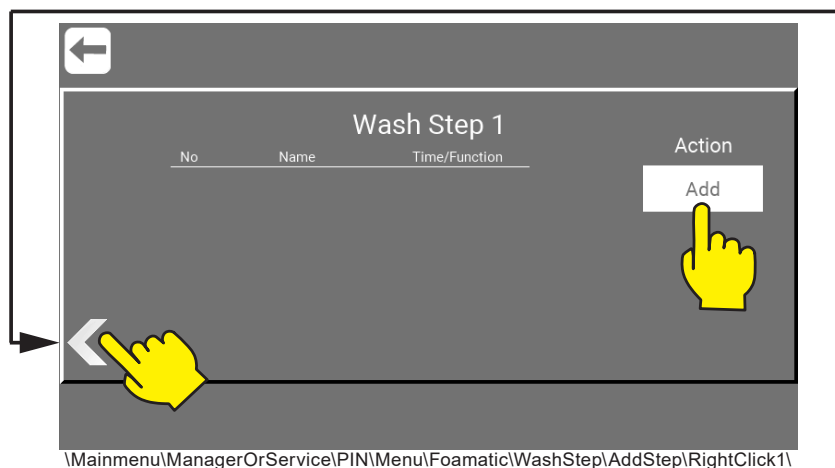

Press the required wash step action e.g. "Activate Output".



\\Mainmenu\ManagerOrService\PIN\Menu\Foamatic\WashStep\AddStep\RightClick1\Add\

Activate Output: function used to let the wash step/program activate an output of the PLC, it could for example be a zone valve, active signal etc. When pressing this symbol a list of available output functions will appear.

Deactivate Output: function used to let the wash step/program deactivate an output. Always make sure outputs activated by previous symbol is also deactivated. The same list as for activating output will appear.

Wait for input: function used when a wash step/program should wait for a given signal before continuing. It could be a feedback signal from a zone valve telling that the zone is actually open or closed.

Wait Time: This function is used to place an adjustable pause in a wash step; the period of the pause is set when creating a wash program. An example could be the time between opening and closing a valve.

Action Pause: this is a pause defined in the wash step; it could for example be a short pause waiting for a valve to close.

Choose the required wash step action, by pressing e.g. "Rinse Valve" button.

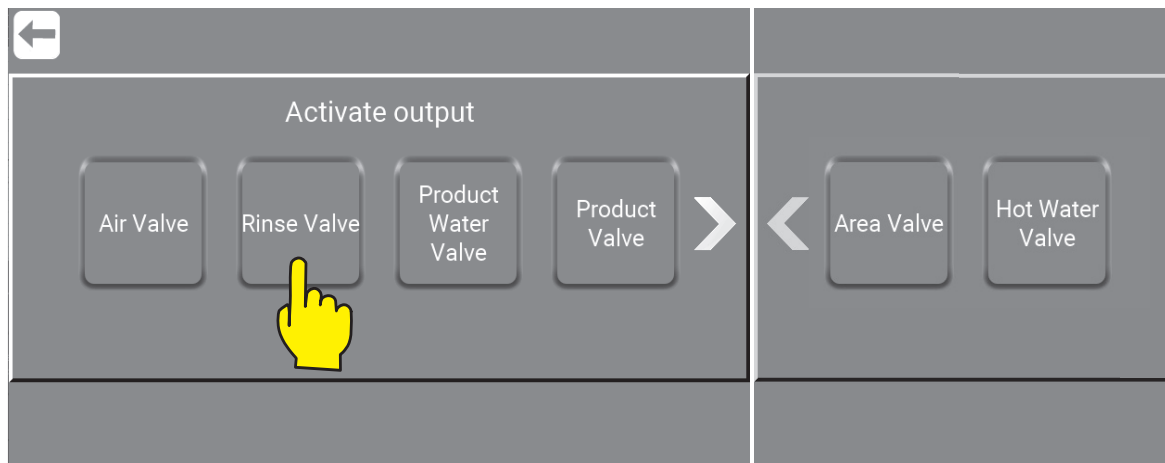

\\Mainmenu\ManagerOrService\PIN\Menu\Foamatic\WashStep\RightClick1\Add\ActivateOutput\...

Description of the different kinds of Outputs possible to activate.

Air Valve : Air valve on automatic block

Rinse Valve : Flush valve on automatic block

Product Water Valve: water to injector on automatic block

Product Valve: chemistry valve from chemistry to injector on automatic block

Area Valve : area valves that are used in the washing program

Hot Water Valve : can be used to open for hot water in the washing program

8.9.14.2. Edit Wash Step

Press "Edit Step".

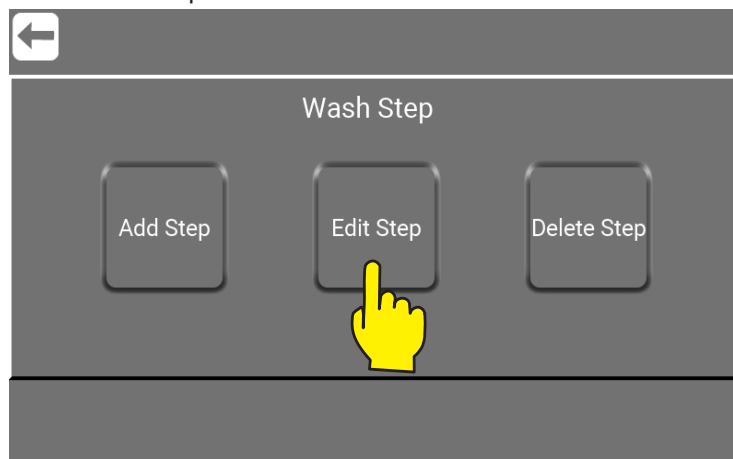

\\Mainmenu\ManagerOrService\PIN\Menu\Foamatic\WashStep\

Choose the required wash step action to edit, by pressing e.g. "Rinse" button.

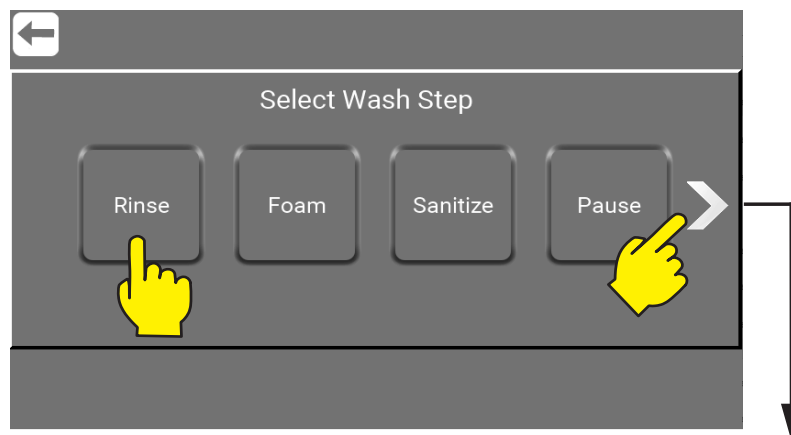

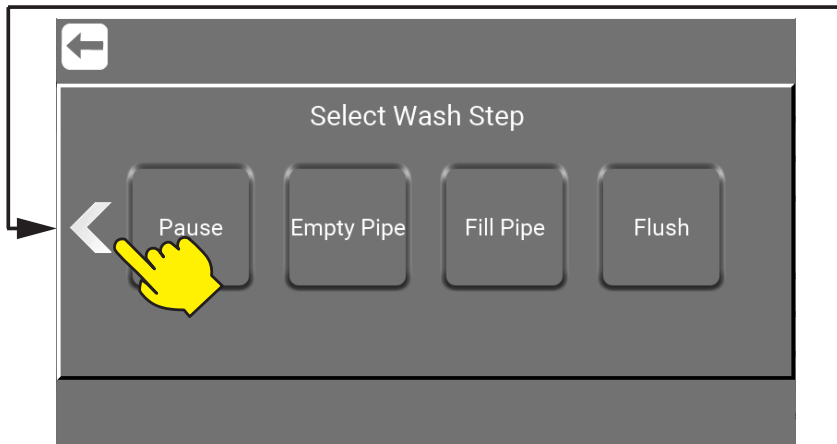

\\Mainmenu\ManagerOrService\PIN\Menu\Foamatic\WashStep\RightClick1\

Select Wash Step e.g. "Rinse" to add it to the wash program.



\\Mainmenu\ManagerOrService\PIN\Menu\Foamatic\WashProgram\EditProgram\WashProgram1\

1) Press to change Wash Step name.

2) Confirm changes.

3) Edit the program wash steps.

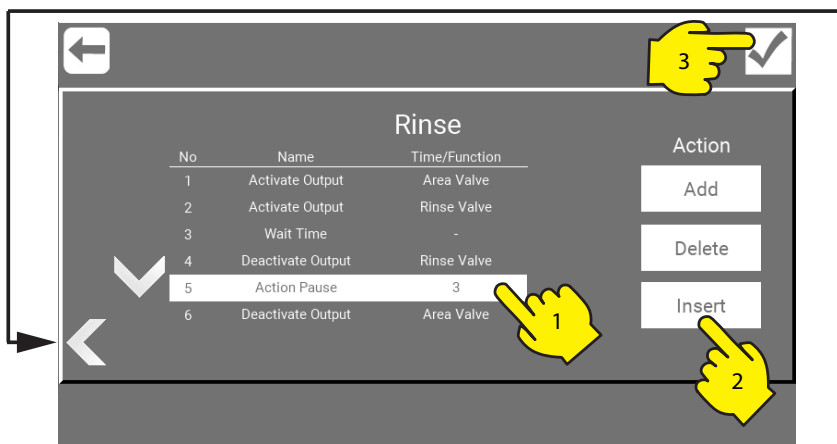

\\Mainmenu\ManagerOrService\PIN\Menu\Foamatic\WashProgram\EditProgram\WashProgram1\RightClick1\

1) Press the the Wash Step that need editing.

2) Add, Delete, Insert og Edit wash step.

3) Confirm changes.

8.9.14.3. Delete Wash Step

Press "Delete Step".

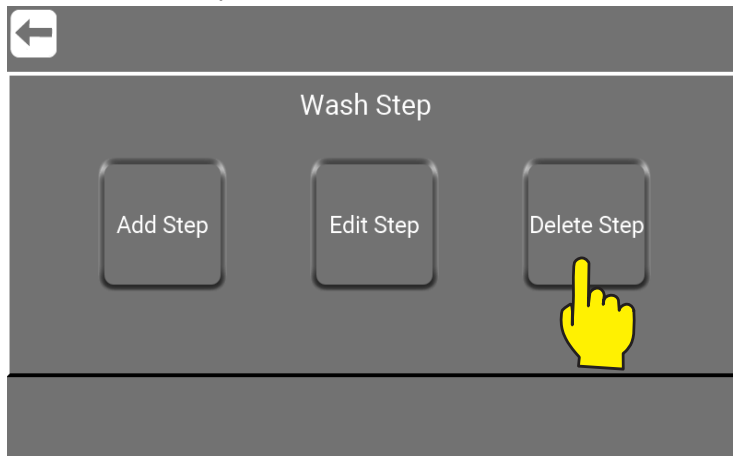

\\Mainmenu\ManagerOrService\PIN\Menu\Foamatic\WashStep\

Choose the required wash step action to delete.
By pressing e.g. "Rinse" button, it will be deleted immediately.

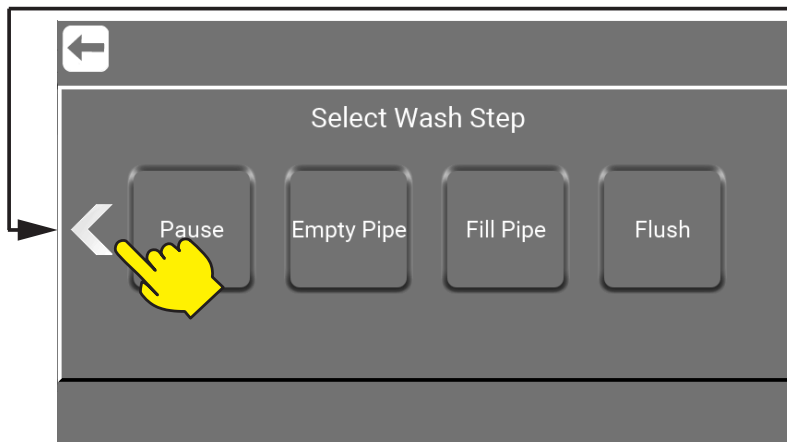
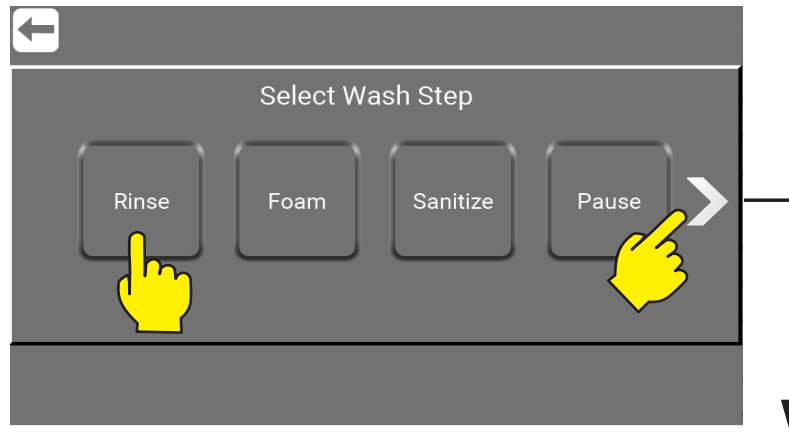

\\Mainmenu\ManagerOrService\PIN\Menu\Foamatic\WashStep\RightClick1\

8.9.15. Wash Programs

Wash programs are used for cleaning; they consists of wash steps, up to 100 steps in each program. This menu describes how to make, edit and delete wash programs. The unit can hold up to 16 wash programs. The wash programs can be created in two ways. In the GUI as shown below or in Nilfisk FOOD Foamatic App.

Important : If the wash program is created in Nilfisk FOOD Foamatic App the file must always for the Multicontroller to be able to recognize it be named **washprg.js**.

8.9.15.1. Create wash program

Press the "Wash Step".

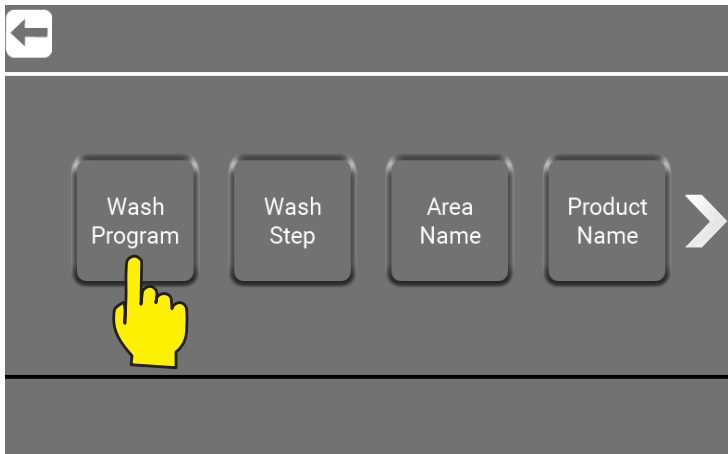

\\Mainmenu\ManagerOrService\PIN\Menu\Foamatic\

Press the "Add Program" button.



\\Mainmenu\ManagerOrService\PIN\Menu\Foamatic\WashProgram\

Press the "Enter Name" field.

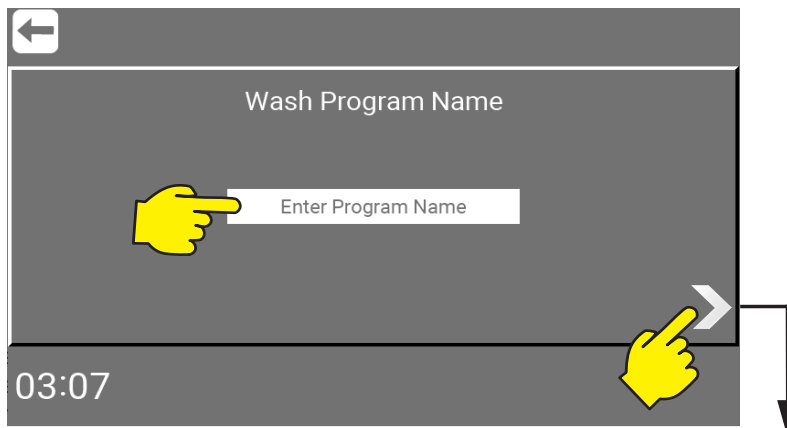

Type in the desired name in for the wash step. Only standard characters and numbers are accepted for the name. It is required for a wash program to have a name, so this field cannot be left blank. The program name can hold a maximum of 16 characters. When done press right arrow.

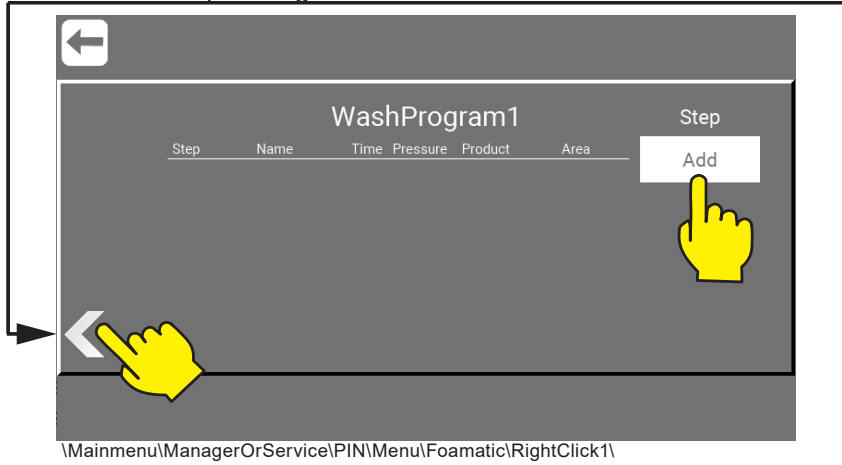

Select Wash Step e.g. "Rinse" to add it to the wash program.

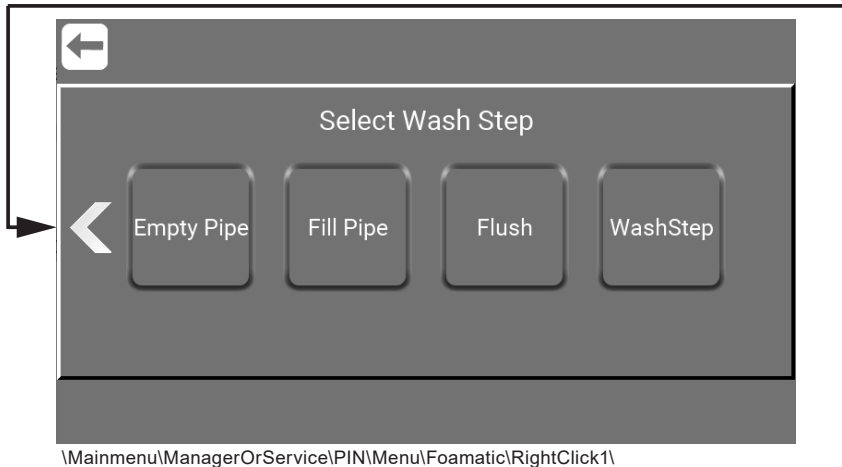
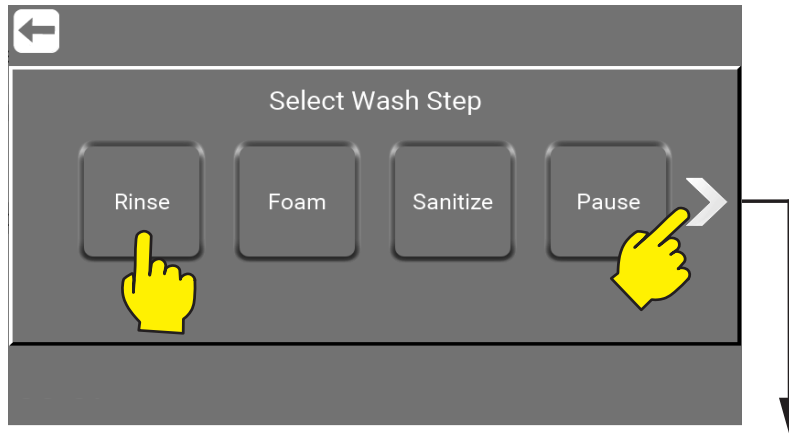

Press time field and press arrow up / down to Set Step Time.

Set Step Time: is the time for wait step time in wash step setup, normally the time the wash step will run. For example the time for rinsing, the maximum time is 166 minutes and 36 sec (9999 sec).

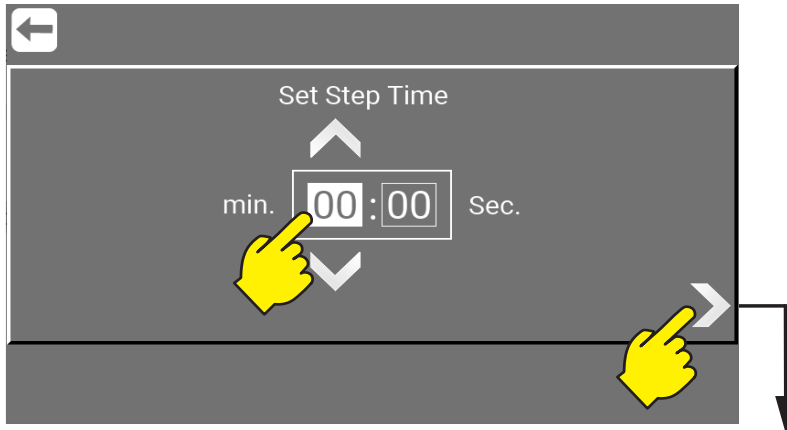

Press arrow up / down to set Step Pressure.

Pressure: Select the desired pressure for the current wash step. Pressure is only visible if the wash step support pressure control, and do not include an activate/deactivate product valve step action, under these circumstance, pressure is set to max (15 bar), for optimal function of the injector

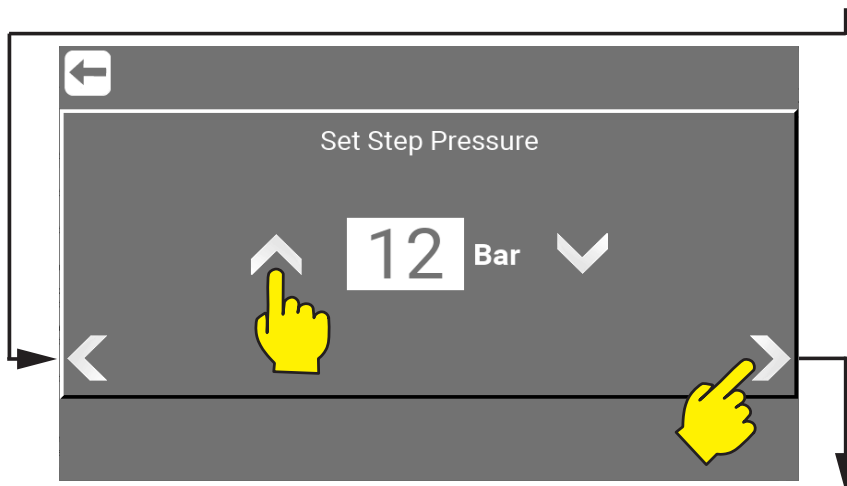

Select Step Area: select which areas that will be activated during wash step. Only enabled if wash step includes an activate / deactivate Area valve action. Only one of the five needs to be set but all five can be set.

More about area go to :
"8.8.3. Area Name - Setup" on page 42

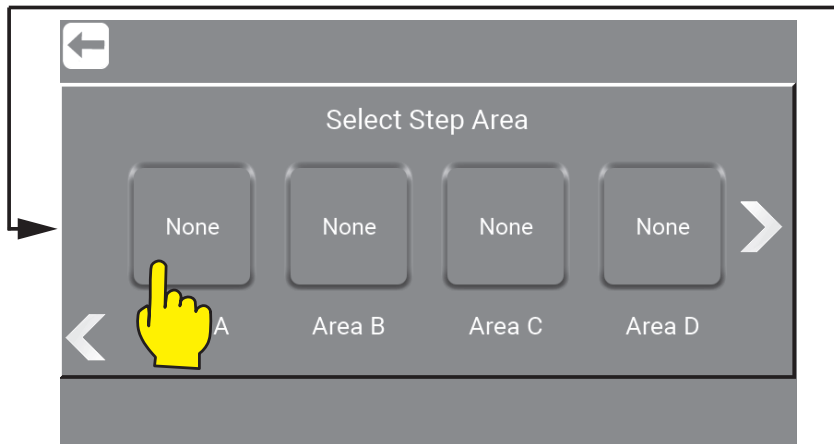

\Mainmenu\ManagerOrService\PIN\Menu\Foamatic\RightClick1\

8.9.15.2. Edit wash program

Press the "Edit Program" button.

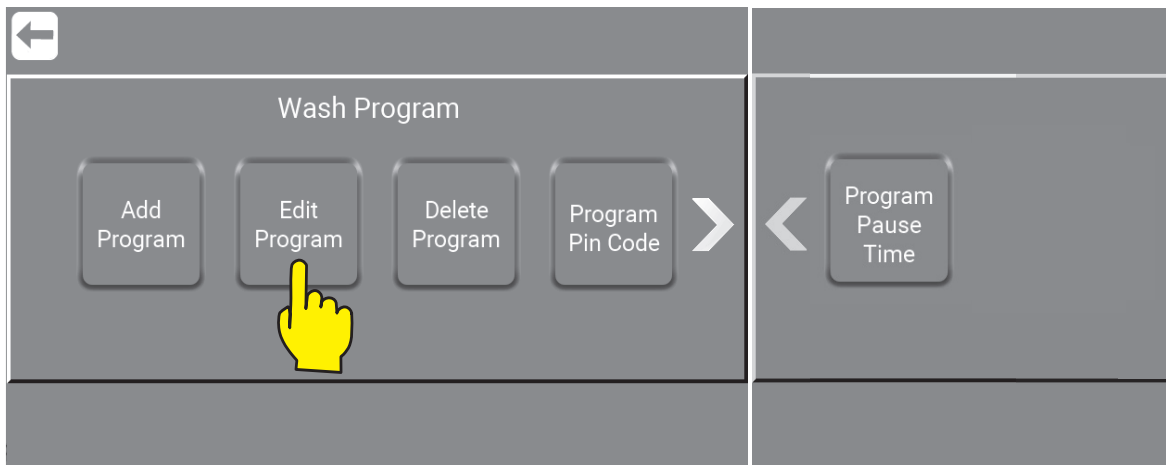

\Mainmenu\ManagerOrService\PIN\Menu\Foamatic\WashProgram\

Press the wash program needed to be edited.

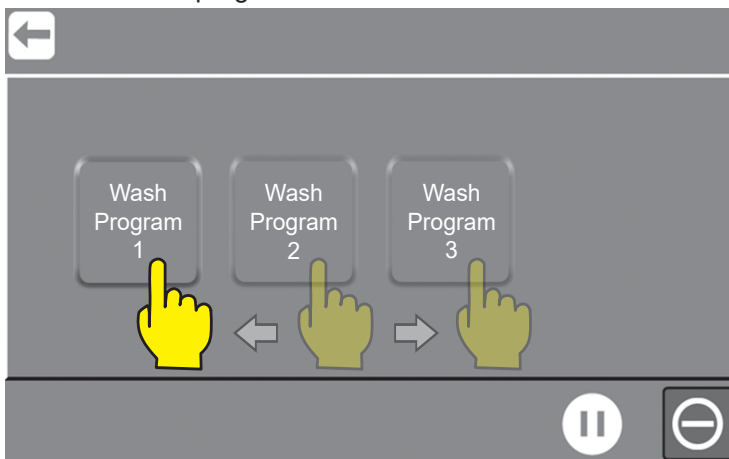

\Mainmenu\ManagerOrService\PIN\Menu\Foamatic\WashProgram\EditProgram\

Select Wash Step e.g. "Rinse" to add it to the wash program.

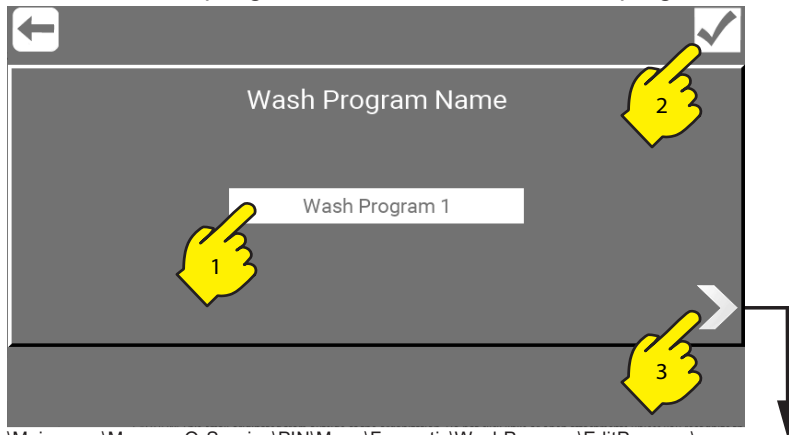

\Mainmenu\ManagerOrService\PIN\Menu\Foamatic\WashProgram\EditProgram\WashProgram1\

- 1) Press to change Wash Program name.
- 2) Confirm changes.
- 3) Edit the program wash steps.

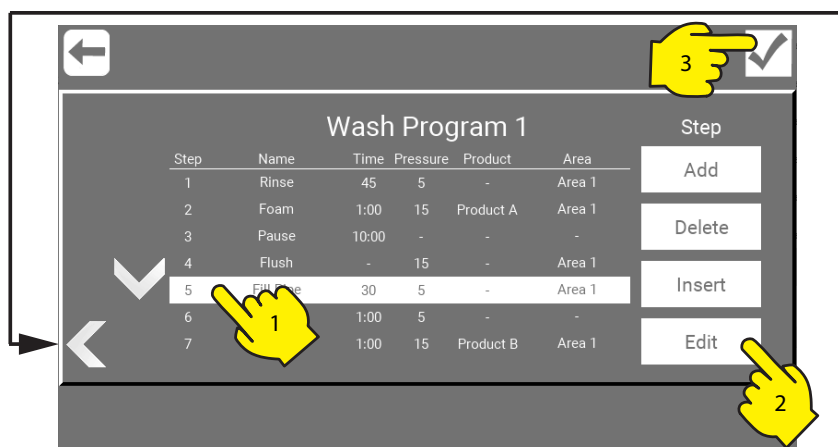

\Mainmenu\ManagerOrService\PIN\Menu\Foamatic\WashProgram\EditProgram\WashProgram1\RightClick1\

- 1) Press the the Wash Step that need editing.
- 2) Add, Delete, Insert og Edit wash step.
- 3) Confirm changes.

8.9.15.3. Delete wash program

Press the "Edit Program" button.

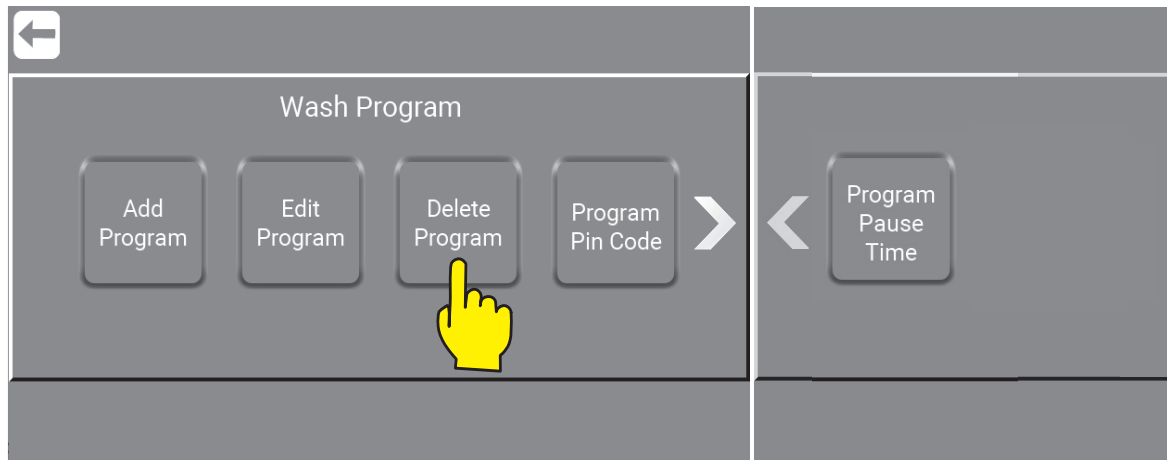

\\Mainmenu\ManagerOrService\PIN\Menu\Foamatic\WashProgram\

Press the wash program needed to be deleted.

By pressing e.g. "Wash Program 1" button, it will be deleted immediately.

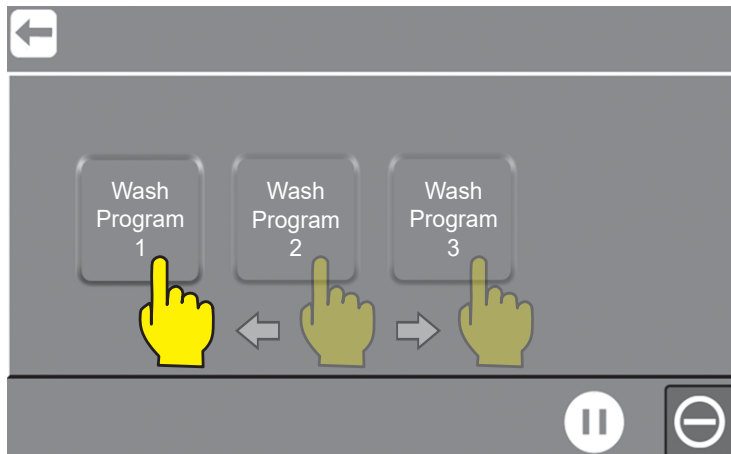

\\Mainmenu\ManagerOrService\PIN\Menu\Foamatic\EditProgram\

8.9.15.4. Program PIN Code

Go to : "4.1. Change PIN Code for Auto / as Manager" on page 12

Go to : "4.2. Change PIN Code for Auto / as Service" on page 12

9. Info

Info about the satellite or mainstations data like machine type, software versions, installation date and different kind of time parameters regarding performance. All data will always automatically be stored / logged.

9.1. Where to find "Info" menu

From the main menu, press the option "Info".

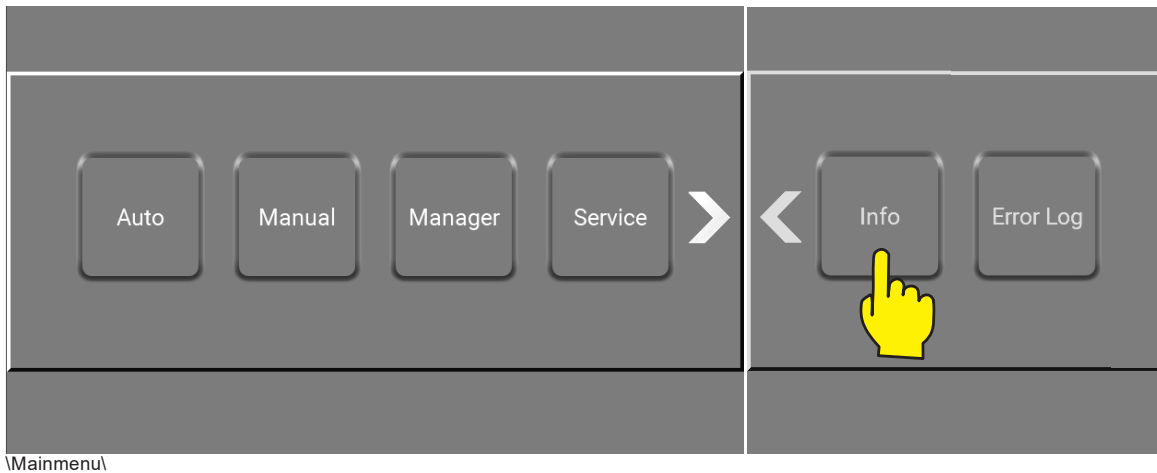

9.1.1. What kind of data to find in "Info".

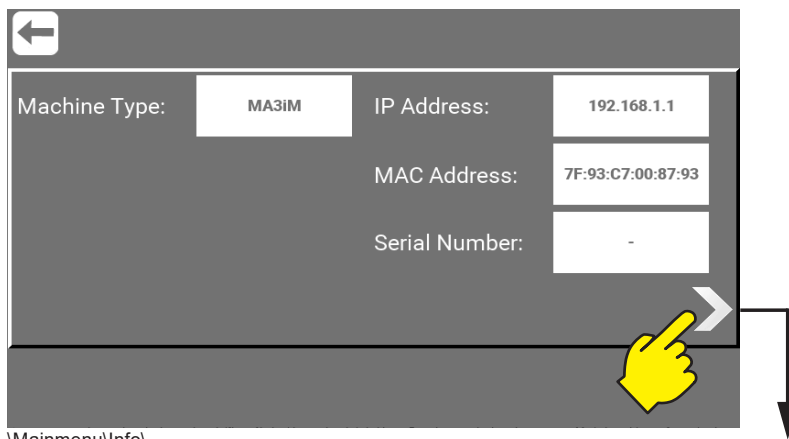

9.1.2.2. Machine type

Machine type is defined on the identification plate.
More about this in Direction for Use manual.

M/S: M: Mainstation / S: Satellite
A: Automatic
2/3: Number of products
I: I/O Moduls
M: Manual Block

9.1.3.3. IP Address

IP Adress, for this unit.

9.1.4.4. MAC Adress

MAC Adress, for this unit.

9.1.5.5. Serial Number

Serial Number, for this unit.

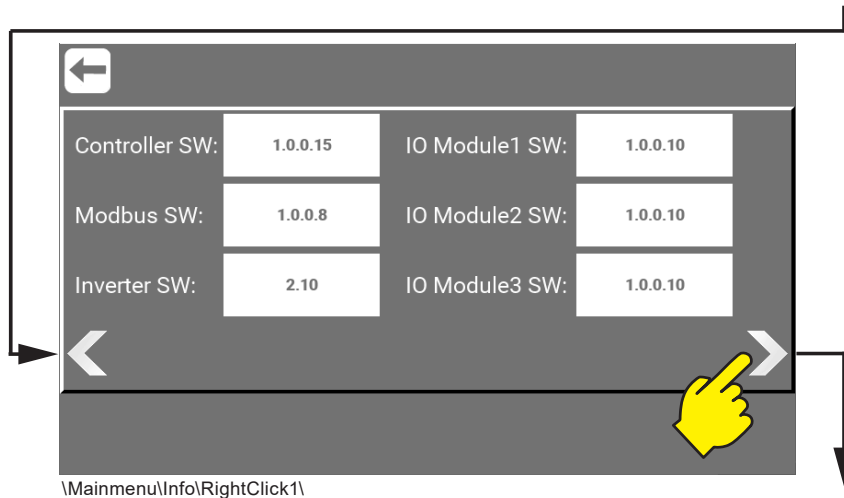

9.1.6.6. Controller SW version

MultiController software, this is the current version.

9.1.7.7. GUI SW version

Graphic User Interface (GUI) software, this is the current version.

9.1.8.8. Modbus SW version

Modbus software, this is the current version.

9.1.9.9. Inverter SW version

Inverter software, this is the current version.

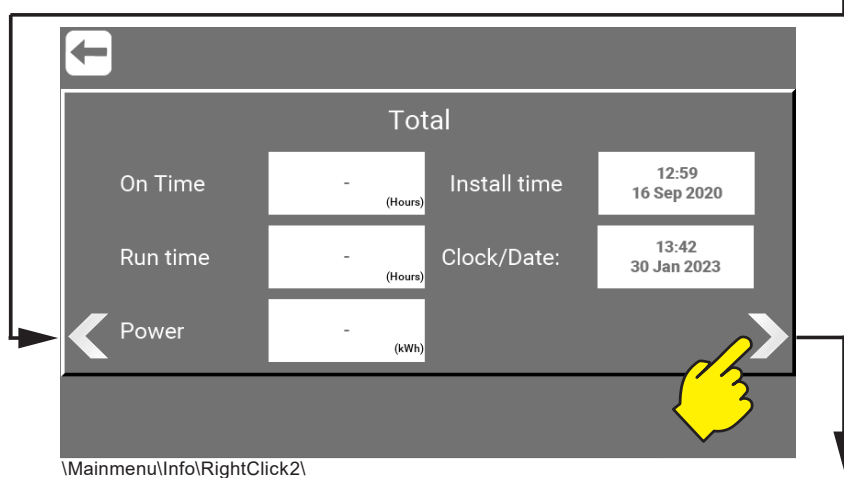

9.1.10.10. On Time

The total amount of hours the unit has been turned on.

9.1.11.11. Run Time

The total amount of hours the unit has been running.

9.1.12.12. Power

The total amount kWh used in the units lift time.

9.1.13.13. Install time

The time, date and year for the units installation.

9.1.14.14. Clock/Date

The current time, date and year.

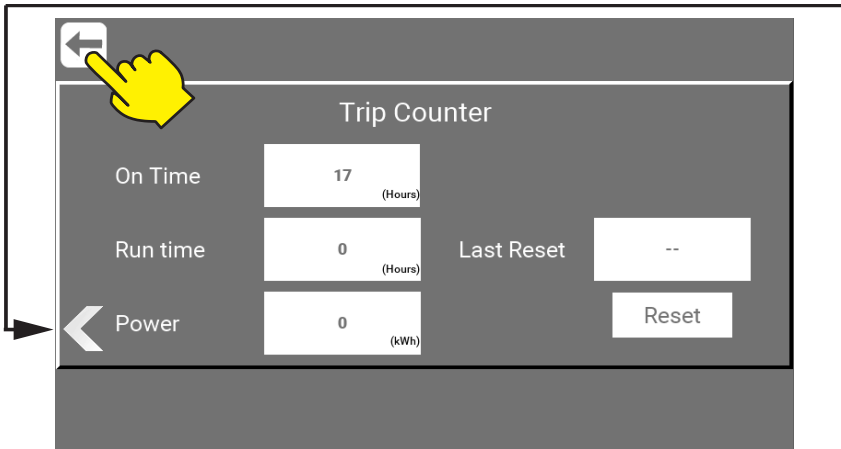

\\Mainmenu\Info\RightClick3\

9.1.15.15. On Time

The number of hours the unit has been turned on since last reset.

9.1.16.16. Run Time

The total number of hours running since last reset.

9.1.17.17. Power

The total amount kWh used since last reset.

9.1.18.18. Last Reset

The time, date and year when the last reset took place.

9.1.19.19. Reset button

This button will reset trip counter.

10. Error Log

In the Error log menu it is possible to see the latest errors and warnings (up to 200 logs). All data will always automatically be stored / logged.

From the main menu, press the "Error Log" button.

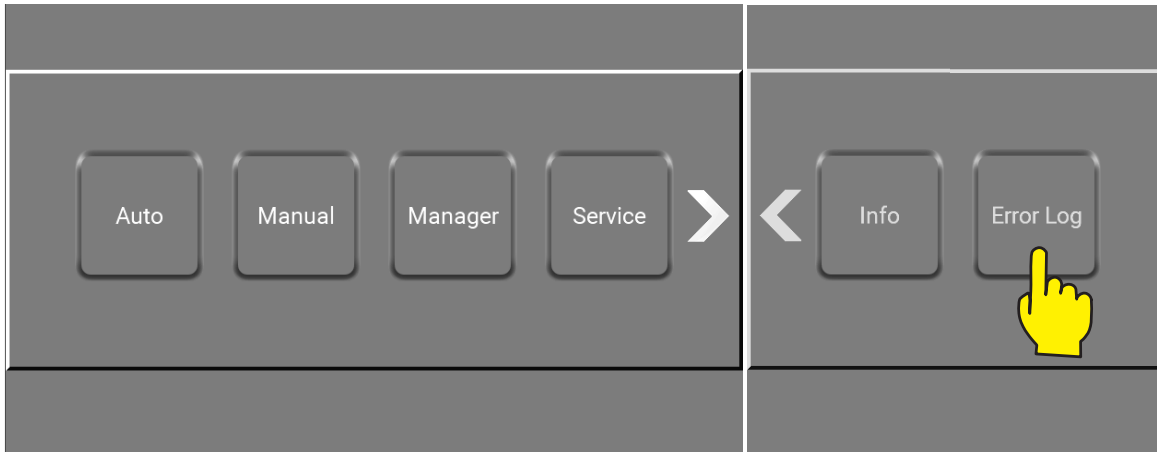

\Mainmenu\

When entering the Error Log menu, the errors and warnings will be shown in chronological order. New ones first. To go to next error or warning press right arrow.

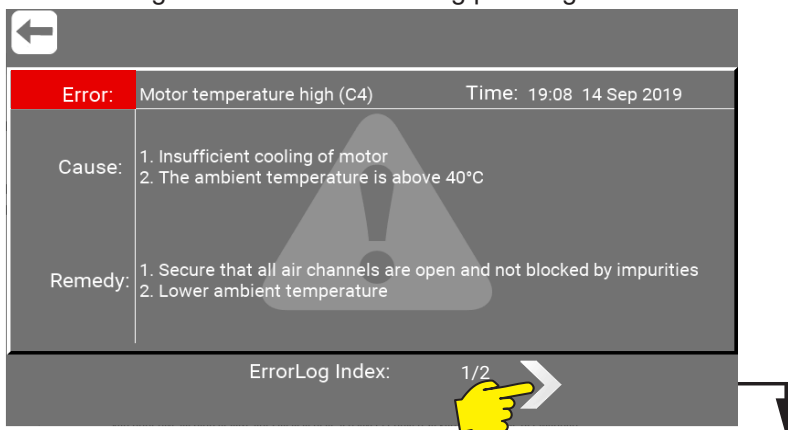

The type of error or warning will be shown in top. In this case:
 Error (Red) : "Motor temperature high (C4)" and
 Warning (Yellow) : Critical inlet pressure (C11).
 A complete list of error and warning codes as
 can be found here. "10.1. Cause/Remedy" on page 72.

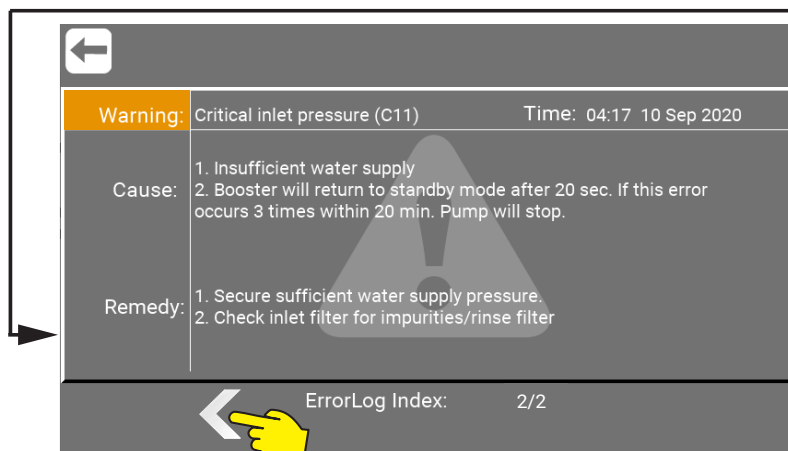

\Mainmenu\ErrorLog\

10.1. Cause/Remedy

This is a complete list of all Error and Warning codes.

Column 1 : Show the identification code. Underneath there is a "E" if it is an error and a "W" if it is a Warning.

Column 2 : Show the description of the error or warning.

Column 3 : Show the cause of the error or warning.

Column 4 : Show what can be done to resolve the error or warning.

Code	Error or Warning	Cause	Remedy
C2 W	Low Supply Pressure	Insufficient water supply	1. Secure sufficient water supply pressure. 2. Check inlet filter for impurities/ rinse filter
C3 E	Water temperature high	1. Water pump top temperature is above 70°C 2. Water consumption is too low (pump column has been overheated)	1. Lower the inlet water temp. (max 70°C) 2. Secure sufficient water consumption
C4 E	Motor temperature high	1. Insufficient cooling of motor 2. The ambient temperature is above 40°C	1. Secure that all air channels are open and not blocked by impurities 2. Lower ambient temperature
C7 E	No Communication	1. No Communication between Display and Inverter.	1. Check cables between display and inverter 2. Power unit off and on
C11 W	Critical inlet pressure	1. Insufficient water supply 2. Booster will return to standby mode after 20 sec. If this error occurs 3 times within 20 min. Pump will stop.	1. Secure sufficient water supply pressure. 2. Check inlet filter for impurities/ rinse filter
C13 W	Inlet Pressure Low	Insufficient water supply. The machine will keep on working, but the maximum speed of the pump will be reduced until sufficient inlet pressure is present	1. Secure sufficient water supply pressure. 2. Check inlet filter for impurities/ rinse filter.
C14 W	Leakage start	1. Booster start condition changed to flow, due to leakage in pipe	1. Check for leakage in pipe system 2. Press "OK" button, and restart
C16 W	Inlet sensor load low	Current consumption from inlet sensor low	1. Check cable and connection to sensor 2. Change sensor
C17 E	Water temperature low	1. Water supply temperature is below limit.	1. Secure higher temperature for supply water. 2. Lower water consumption.
C18 E	Suction Lance 2, empty	Level of product in chemistry canister for product B is insufficient	1. Replace chemistry canister and ensure level of product is above min. limit

C20 W	Low Sensor Signal Outlet Sensor	1. Pressure signal from outlet sensor, out of range	1. Check cable connection to outlet sensor 2. Check outlet sensor 3. Press "OK" button, and restart
C22 W	Low Sensor Signal Inlet sensor	1. Pressure signal from inlet sensor, out of range	1. Check cable connection to inlet sensor 2. Check inlet sensor 3. Press "OK" button, and restart
C26 W	Outlet sensor load low	Current consumption from Outlet sensor low	1. Check cable and connection to sensor 2. Change sensor
C27 W	Flowswitch Load Low	Flowswitch current consumption is below limit	1. Check cable and connection to sensor 2. Change sensor
C28 W	Suction Lance 1, Low	Level of product in chemistry canister for product A is low	1. Replace chemistry canister for product A
C29 W	Suction Lance 2, Low	Level of product in chemistry canister for product B is low	1. Replace chemistry canister for product B
C40 W	Sensor Load High Outlet Sensor	1. Outlet sensor using too much current	1. Press "OK" button, and restart 2. Change Outlet sensor
C43 W	Flowswitch load high	1. Flowswitch using too much current	1. Press "OK" button, and restart 2. Change flowswitch
C44 E	Suction Lance 1, empty	1. Level of product in chemistry canister for product A is insufficient	1. Replace chemistry canister and ensure level of product is above min. limit
C45 W	Inverter Module Temperature too high.	1. Water consumption too high. 2. Ambient temperature too high.	1. Lower the load for inverter. 2. Lower the ambient temperature.
C46 W	Inverter Board Temperature high.	1. Water consumption too high. 2. Ambient temperature too high. 3. Load at board high.	1. Lower the load for inverter. 2. Lower the ambient temperature. 3. Lower the load at board.
C50 E	Current phase 1,	Too high current on motor phase 1	1. Control power on all 3 phases 2. Reduce motor load
C51 E	Current phase 2,	Too high current on motor phase 2	1. Control power on all 3 phases 2. Reduce motor load
C52 E	Current phase 3,	Too high current on motor phase 3	1. Control power on all 3 phases 2. Reduce motor load
C53 E	Motor sum current too high	1. In-balance between motor-currents. 2. Current leaking to Earth, Ground Fault.	1. Check Motor and Cable.
C54 E	Supply Low Weak Supply.	1. Power to inverter too low 2. Missing a phase	1. Secure stable power supply.
C55 E	Supply to high	1. Supply out of range.	1. Secure stable power supply.

C56 E	Current too high	Short circuit between motor-current cable and earth or other motor-current cable.	1. Check Motor and Cables.
C57 E	Safe Torque off	1. Emergency circuit has been opened / broken.	1. Check all emergency switches and cables.
C58 E	Inverter Module Temperature too high.	1. Water consumption too high. 2. Ambient temperature too high.	1. Lower the load for inverter. 2. Lower the ambient temperature.
C59 E	Serial no. or Rev. no. not correct	1. No.'s has not been read correct 2. No. not written to memory	1. Repower unit 2. Call service technician
C68 W	Suction Lance 3, low	Level of product in chemistry canister for product C is low	1. Replace chemistry canister for product C
C69 E	Suction Lance 3, Empty	1. Level of product in chemistry canister for product 3 is insufficient.	1. Replace chemistry canister for product is above minimum limit.
C70 E	Suction Lance Global, empty	Level of product in any chemistry canister is insufficient	1. Replace chemistry canister and ensure level of product is above min. limit
C71 W	Suction Lance Global, low	Level of product in any chemistry canister is low	1. Control and Replace chemistry canisters
C72 W	Wash program not released	Release signal not present when starting wash program	Ensure correct signal at input for release wash program
C73 W	No release hold for washprogram	Release hold signal removed during running wash program	Ensure correct signal at input for release hold of wash program
C74 E	External Error	1. Error input signal coming from external device.	1. Reset signal from external device.
C75 E	Safety Active	Input signal indicating safety circuit is activated	1. Remove cause of safety error 2. Reset Error
C76 E	USB Setup file invalid	1. Content of setup file at USB invalid 2. USB defective	1. Copy backup file to USB 2. Replace USB flash with new incl. correct setup file
C77 W	USB Setup file reset to last known valid state.	Content of setup file at USB invalid.	1. Restart Foamatic unit 2. Verify washprograms and port settings
C78 W	USB Setup file reset to default state	Content of setup file at USB invalid and no known setup in memory	1. Restart Foamatic unit 2. Reprogram washprograms and port settings
C79 E	No Communication to IO module-1	1. No power to IO module 2. Com. cable to IO module not mounted 3. Dip switch setting not correct	1. Remove lid and verify light in LED 24V and 3V3 2. Ensure com cable is connected correct in both ends 3. Verify dip switch position (1:OFF / 2:OFF)

C80 E	No Communication to IO module-2	1. No power to IO module 2. Com. cable to IO module not mounted 3. Dip switch setting not correct\n"	1. Remove lit and verify light in LED 24V and 3V3 2. Ensure com cable is connected correct in both ends 3. Verify dip switch position (1:OFF / 2:OFF)
C81 E	No Communication to IO module-3	1. No power to IO module 2. Com. cable to IO module not mounted 3. Dip switch setting not correct\n"	1. Remove lit and verify light in LED 24V and 3V3 2. Ensure com cable is connected correct in both ends 3. Verify dip switch position (1:OFF / 2:OFF)
C82	External activation timeout	1. Area valve not activated 2. Feedback signal from area valve not connected	1. Verify that all signals are connected 2. Control area valves are opening as expected 3. Measure feedback signal from area valve
C83 E	Release signal is not activated	Unit can not run due to one or more Release function inputs are not activated	1. Control all inputs causing Release machine is present. 2. Restart unit"
C84 E	Blocked signal is activated	Unit can not run due to one or more blocked function inputs are activated	1. Control all inputs causing Blocked machine is no longer present. 2. Restart unit
C85 E	No Flow detected	Unit does not detect flow in running wash program.	1. Ensure flow switch is working 2. Ensure all valves opens as expected.

When in doubt or if error still occurs, please contact your local service technician.

11. Software update

To update software for Multicontroller, Inverter, Internal I/O and / or external I/O Modules use the following instructions.

11.1. Hardware needed to update software

We recommend using a USB flash drive with Min. 1GB and Max. 32GB.
Sparepart no.: 110009400 with newest HYBRID 7 Software on it.



Important : The USB flash drive must be formatted in **FAT32** format.

It is also highly recommended to use a separate USB flash drive for the units software updates, and not use the same as for other things.

Important : We highly recommend that a backup of the Washprg folder is stored on secondary location before the software upgrade is started.

11.2. Download of the new software

The software for updating the Multicontroller, Inverter, Internal I/O and / or external I/O Modules can be found at Nilfisk Food website www.nilfiskfood.com in the automatic download section.

When the software is located and verified :

1. **Download the zip file to a PC.**
2. **Open and extract the zip file,**
3. **Copy the files to a USB Flash Drive.**
4. **The file structure should look like this (No prioriticed order):**

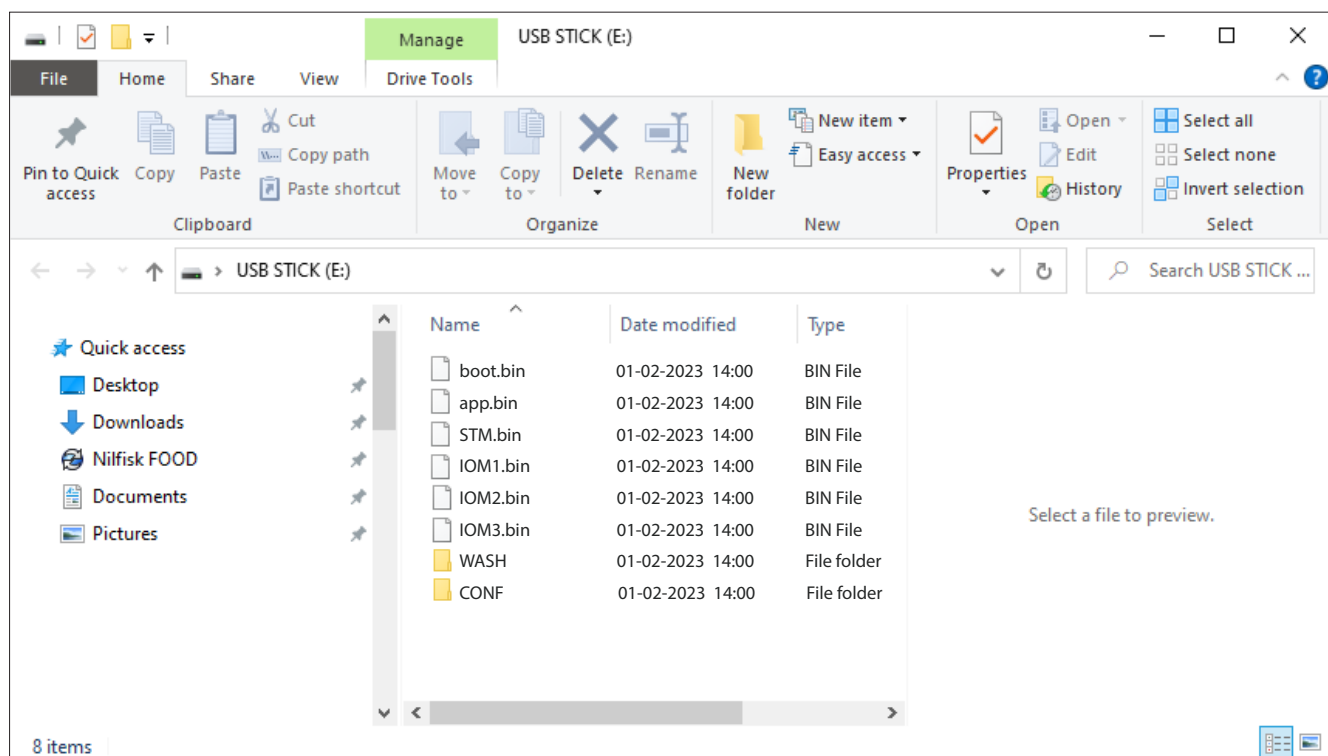

This is the order in which the software / update files should be used.

11.3. Update files and their functions

When the software needs an update each of the 6 files have functions of their own. These functions are specified here:

boot.bin :

Bootloader for Nilfisk FOOD software updates.

The Bootloader is the first file you need to run as it provides an interface for the user to load the applications.

app.bin :

Update file for the MultiController application.

Update file for the Grafich User interface (GUI)

Update file for the Inverter communication.

STM.bin :

Update file for the Inverter communication.

Update file for the Modbus.

IOM1.bin :

Update file for the **internal** I/O module application.

Updates for the communication between I/O module 1 and the Multicontroller.

IOM2.bin :

Update file for the **external** I/O module application.

Updates for the communication between I/O module 2 and the Multicontroller.

IOM3.bin :

Update file for the **external** I/O module application.

Updates for the communication between I/O module 3 and the Multicontroller.

11.4. Installation of the updates

Press "Upgrade Software".

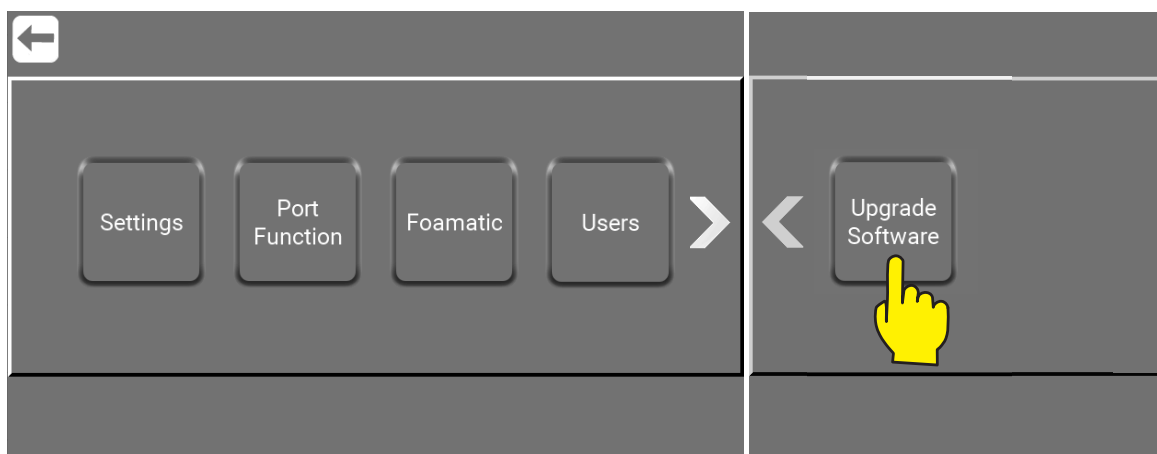

\\Mainmenu\Service\PIN\Menu\

Press "Upgrade Local"

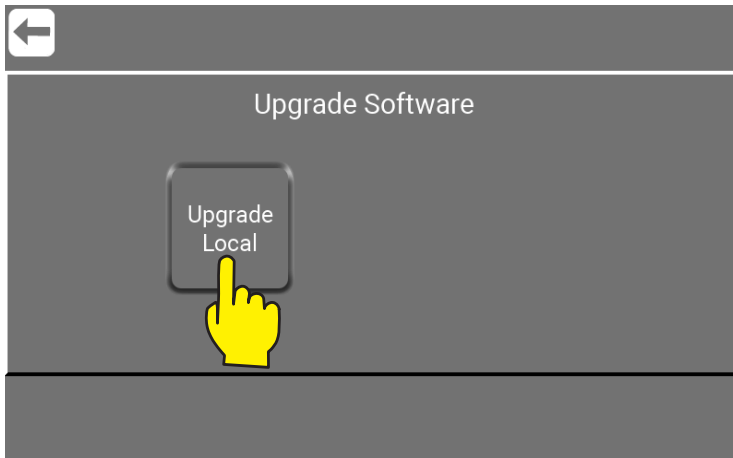

\\Mainmenu\Service\PIN\Menu\UpgradeSoftware\

1. Remove the 7 screws in front to open the multicontroller.

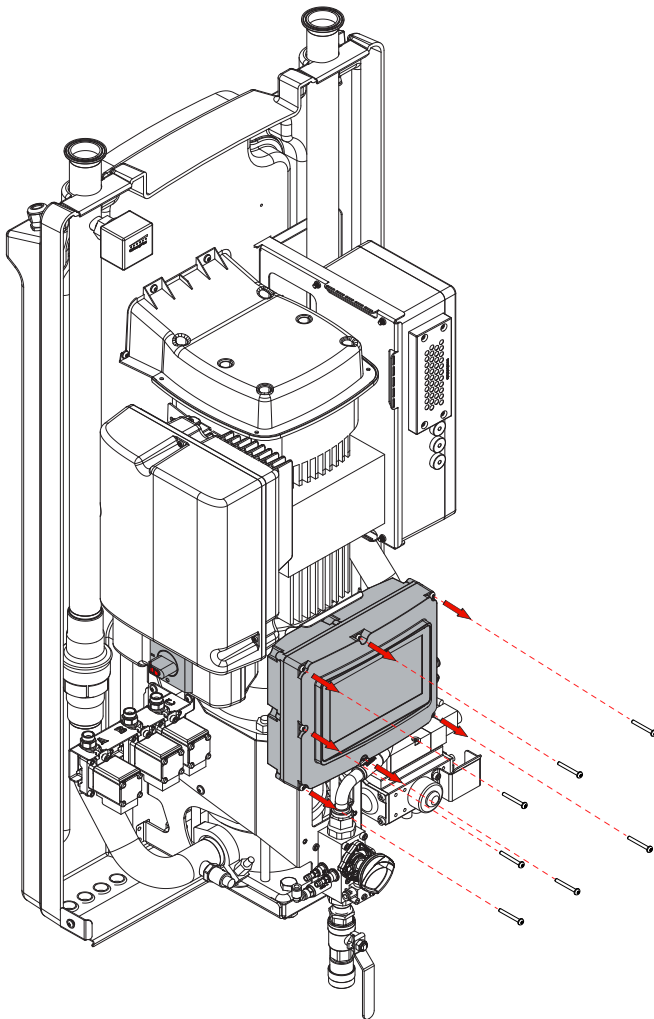

2. When the multicontroller is open you will inside see a USB connection in the right part.

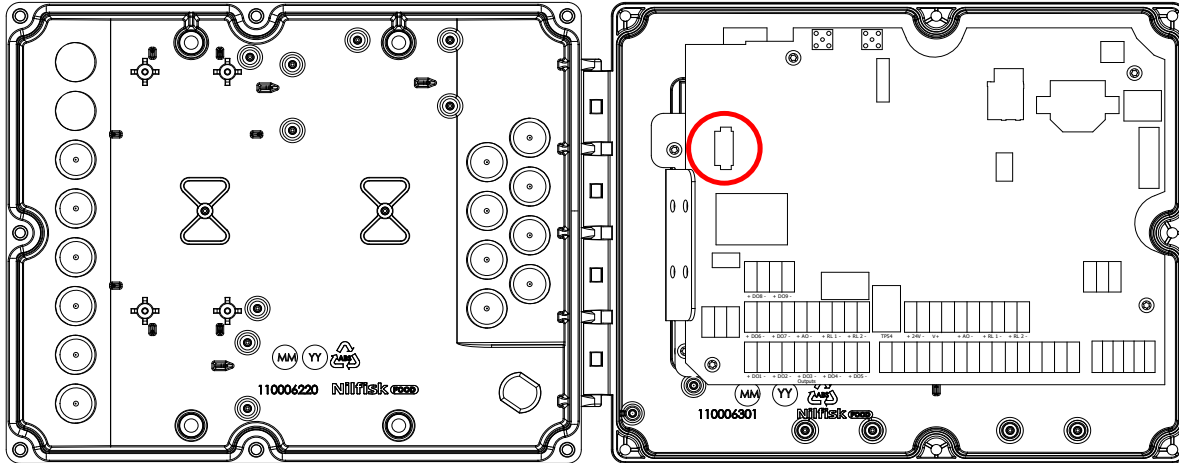

3. Insert the USB flash drive with the new software in to the USB Connection. Make sure the USB flash drive is in the USB connector and Press "OK".

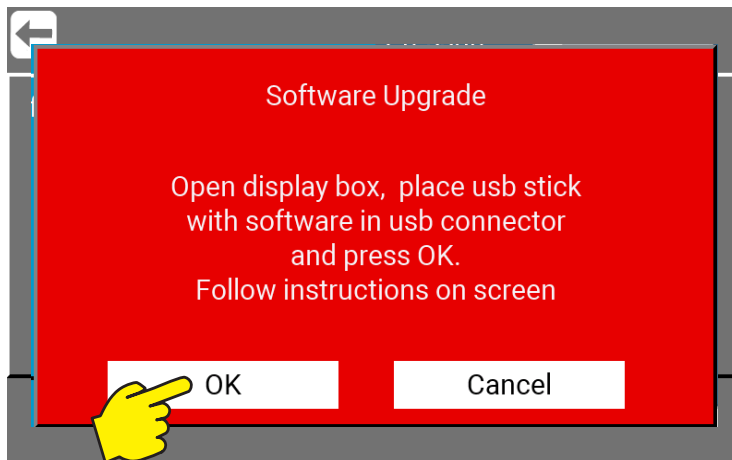

\\Mainmenu\Service\PIN\Menu\UpgradeSoftware\UpgradeLocal\

4. The Multicontroller will by it self check the USB for new versions of software and firmware. And if found start the upload. See the display for status, that could look like this :

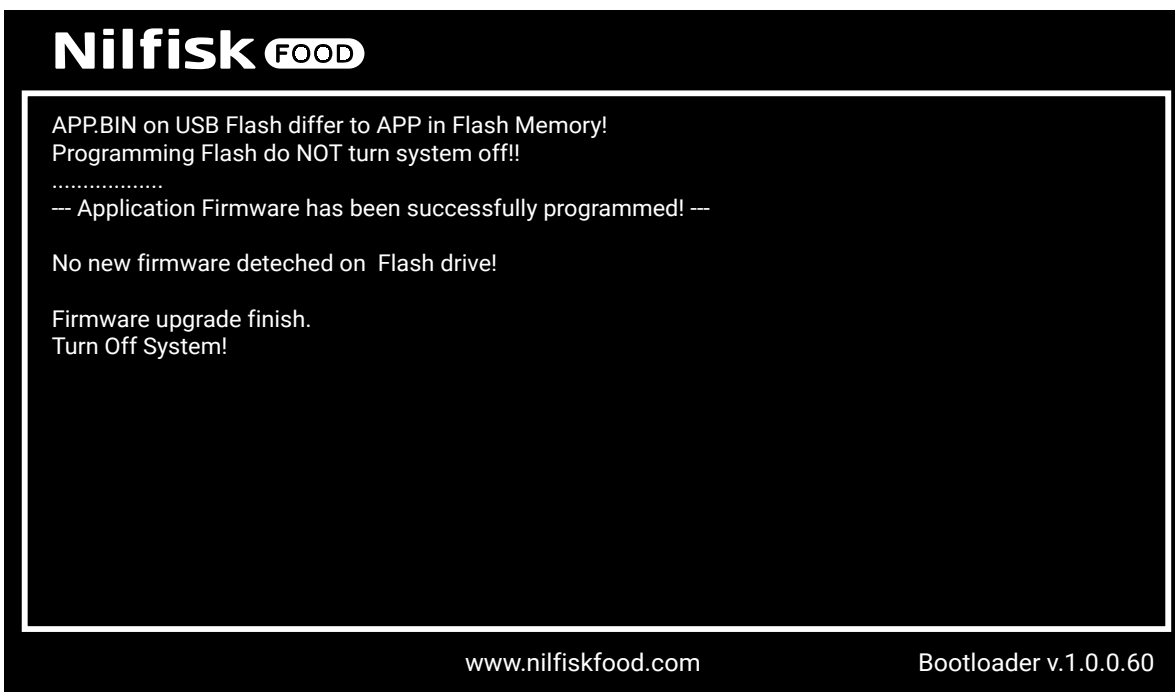

5. Now the USB Flash Drive can be removed, left or replace with the one normally used for wash programs and I/O setup.

IMPORTANT !

Be careful that the USB Flash drive is **max. 20 mm long** if left inside the Multicontroller ! If too long it can damage the print and hardware. A USB flash drive like the one delivered with the unit, can be ordered with the newest HYBRID 7 Software on it. Sparepart no.: 11009400.

6. Close the Multicontroller and remount again all the 7 screws.
7. Turn off the power, on the Inverter.
An wait for the display and then wait for additional 5-10 sec.



8. Turn on power, on the Inverter.



9. The Multicontroller will restart automatically.
10. Go verify that the software version is correct.
See "9.1.5.5. Controller SW version" on page 68

12. I/O Modul setup

If more inputs / outputs are wanted it is possible to purchase and add additional two external I/O Modules, each modules giving 16 outputs and 16 inputs more.

12.1. Add I/O Module

Enter the Service menu.

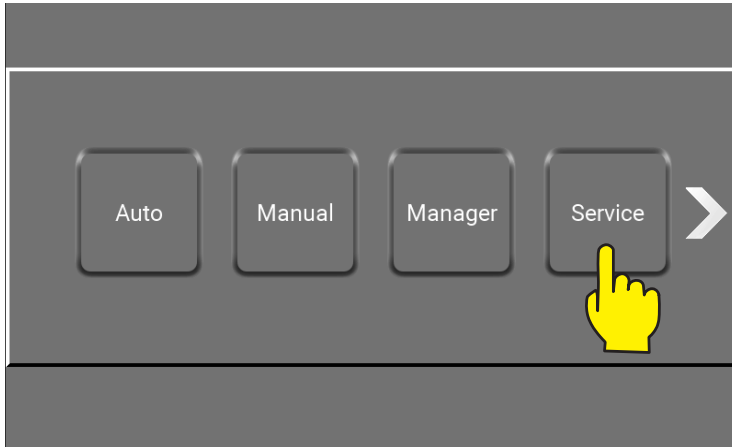

\\Mainmenu\Service\

The Service button in main menu is password protected and a numeric keypad will show up. Enter the correct code and complete with OK.



\\Mainmenu\Service\

Press Menu.

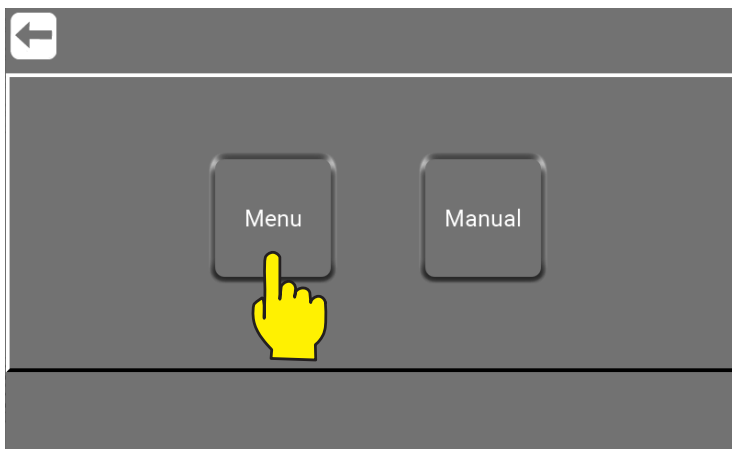

\\Mainmenu\Service\PIN\

Press the "Foamatic" button.

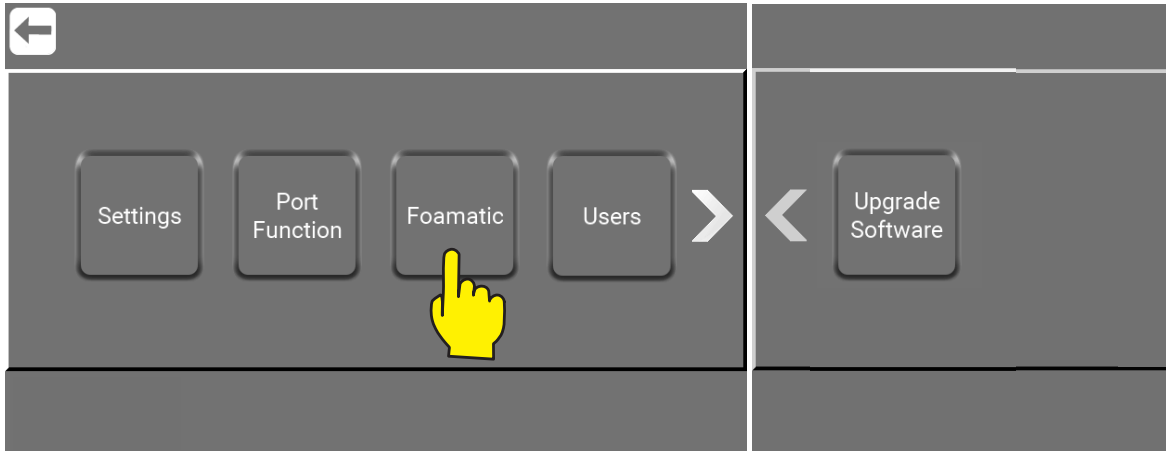

\\Mainmenu\Service\PIN\Menu\

Press the "Ekstra IO Module" button.

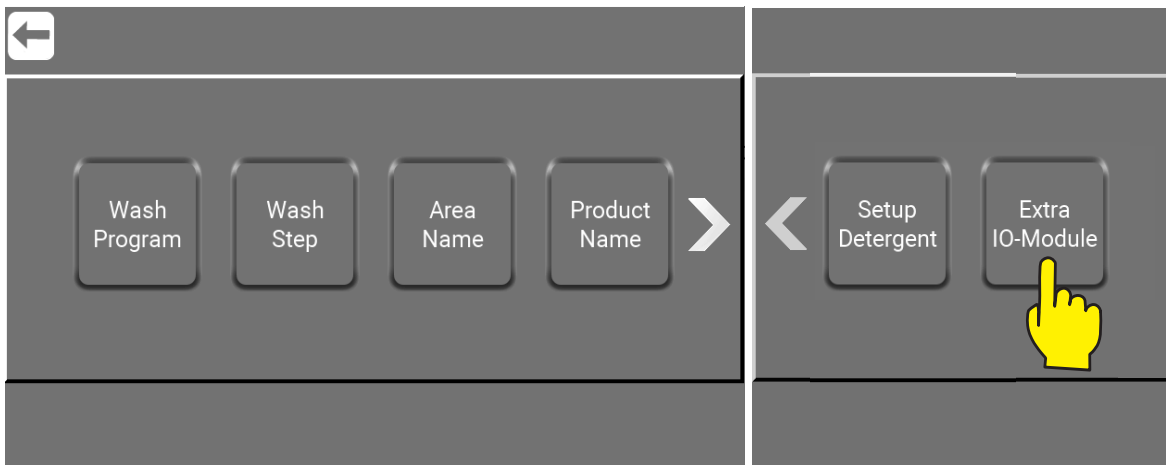

\\Mainmenu\Service\PIN\Menu\Foamatic\

Press the arrow up to add 1 or 2 external I/O Moduls.
And then Confirm number of modules.

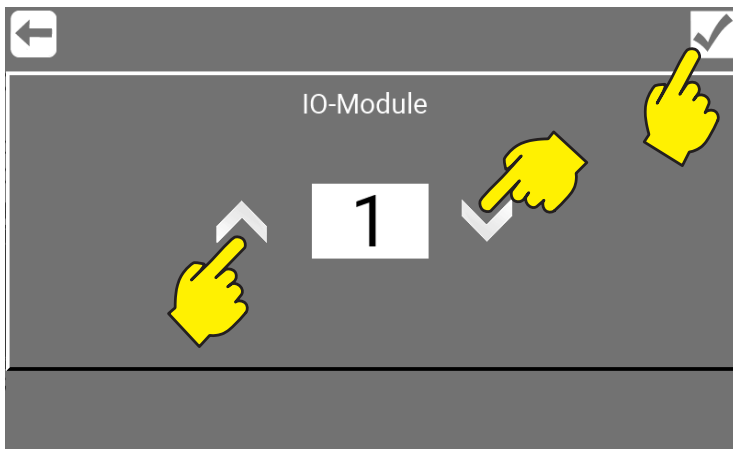

\\Mainmenu\Service\PIN\Menu\Foamatic\ExtraIOModule\

Serial no. 204.01.000XXX
110009192C/110009195C
05/2023