

Hybrid 7 Foamatic

MA2iM, MA3iM, MA2i, MA3i, MA2, MA3, MA2M, MA3M, SA2iM, SA3iM, SA2i, SA3i.

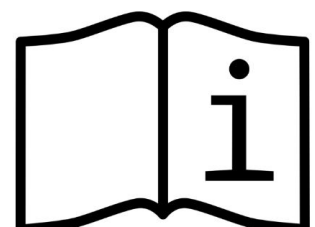

(EN) Directions for use (original)



Available manuals for this unit:

110009190 Direction for use - Hybrid7 Foamatic MA/SA

110009191 Userguide - Hybrid7 Foamatic MA/SA

110009192 Software manual - Hybrid7 Foamatic MA/SA

110009305 Installation manual Hybrid7 Foamatic I/O Extension module (Accessory)

Where to find them :

Direction for use and Userguide will be enclosed as physical paper manuals with the unit.

The software manual must be downloaded from www.nilfiskfood.com - in order to ensure that you always have the latest updated version. (It is not supplied with unit in paper form).

Installation manual Hybrid7 Foamatic I/O Extension module will be enclosed as physical paper manuals with the extension module purchased as an accessory.

At any given time, all manuals can be obtained online at www.nilfiskfood.com.

Declaration of Conformity

EN Declaration of Conformity	DE Konformitätserklärung
FR Déclaration de Conformité	IT Dichiarazione di Conformità
ES Declaración de Conformidad	PT Declaração de Conformidade
EL Δήλωση Συμμόρφωσης	NL Overeenkomstigheidsverklaring
SV Försäkran om överensstämmelse	FI Vaatimustenmukaisuusvakuutus
DA Overensstemmelseserklæring	PL Deklaracja zgodności
RU Декларация о соответствии	HU Megfelelőségi nyilatkozat
SI Izjava o skladnosti	HR Izjava o usklađenosti
HU Deklaracija o konformitetu	RO Declarație de Conformitate
BG Декларация за съответствие	CZ Prohlášení o shodě
SK Prehlásenie o konformite	TR Uygunluk Bildirgesi
EST Vastavusdeklaratsioon	LT Atitikties deklaracija
LV Paziņojums par atbilstību prasībām	UK Свідчення про відповідність вимогам

Nilfisk FOOD
Blytaekkervej 2
9000 Aalborg
Denmark

EN Declaration of Conformity

We Nilfisk FOOD, declare under our sole responsibility that the products **MA2iM, MA3iM, MA2i, MA3i, MA2, MA3, MA2M, MA3M, SA2iM, SA3iM, SA2i, SA3i**, to which this declaration relates, are in conformity with these Council directives on the approximation of the laws of the EC member states:

Machinery Directive (2006/42/EC).

- EN 60335-2-79:2012

EMC Directive (2014/30/EU)

- EN 55014-1:2021

- EN 55014-2:2021

- EN 61000-3-2:2019

- EN 61000-3-3: 2013

FR Déclaration de conformité

Nous, Nilfisk FOOD, déclarons sous notre seule responsabilité, que les produits **MA2iM, MA3iM, MA2i, MA3i, MA2, MA3, MA2M, MA3M, SA2iM, SA3iM, SA2i, SA3i**, auxquels se réfère cette déclaration, sont conformes aux Directives du Conseil concernant le rapprochement des législations des Etats membres CE relatives aux normes énoncées ci-dessous :

Directive Machines (2006/42/EC).

- EN 60335-2-79:2012

Directive Compatibilité Electromagnétique CEM (2014/30/EU)

- EN 55014-1:2021

- EN 55014-2:2021

- EN 61000-3-2:2019

- EN 61000-3-3: 2013

ES Declaración de conformidad

Nosotros, Nilfisk FOOD, declaramos bajo nuestra entera responsabilidad que los productos **MA2iM, MA3iM, MA2i, MA3i, MA2, MA3, MA2M, MA3M, SA2iM, SA3iM, SA2i, SA3i**, a los cuales se refiere esta declaración, están conformes con las Directivas del Consejo en la aproximación de las leyes de los Estados Miembros del EM: Directiva de Maquinaria (2006/42/EC).

- EN 60335-2-79:2012

Directiva EMC (2014/30/EU)

- EN 55014-1:2021

- EN 55014-2:2021

- EN 61000-3-2:2019

- EN 61000-3-3: 2013

EL Δήλωση συμμόρφωσης

Εμείς, η Nilfisk FOOD, δηλώνουμε με αποκλειστικά δική μας ευθύνη ότι τα προϊόντα **MA2iM, MA3iM, MA2i, MA3i, MA2, MA3, MA2M, MA3M, SA2iM, SA3iM, SA2i, SA3i**, στα οποία αναφέρεται η παρούσα δήλωση, συμμορφώνονται με τις εξής Οδηγίες του Συμβουλίου περί προσέγγισης των νομοθεσιών των κρατών μελών της ΕΕ: Οδηγία για μηχανήματα (2006/42/EC).

- EN 60335-2-79:2012

Οδηγία Ηλεκτρομαγνητικής Συμβατότητας (EMC) (2014/30/EU).

- EN 55014-1:2021

- EN 55014-2:2021

- EN 61000-3-2:2019

- EN 61000-3-3: 2013

DE Konformitätserklärung

Wir, Nilfisk FOOD, erklären in alleiniger Verantwortung, dass die Produkte **MA2iM, MA3iM, MA2i, MA3i, MA2, MA3, MA2M, MA3M, SA2iM, SA3iM, SA2i, SA3i**, auf die sich diese Erklärung bezieht, im Einklang mit diesen Richtlinien des Rates zur Angleichung der Rechtsvorschriften der EG Mitgliedstaaten stehen:

Maschinenrichtlinie (2006/42/EC).

- EN 60335-2-79:2012

EMV Richtlinie (2014/30/EU)

- EN 55014-1:2021

- EN 55014-2:2021

- EN 61000-3-2:2019

- EN 61000-3-3: 2013

IT Dichiarazione di conformità

Nilfisk FOOD dichiara sotto la sua esclusiva responsabilità che i prodotti **MA2CM, MA2iM, MA3iM, MA2i, MA3i, MA2, MA3, MA2M, MA3M, SA2iM, SA3iM, SA2i, SA3i**, ai quali si riferisce questa dichiarazione, sono conformi alle seguenti direttive del Consiglio riguardanti il riavvicinamento delle legislazioni degli Stati membri CE:

Direttiva Macchine (2006/42/EC).

- EN 60335-2-79:2012

Direttiva EMC (2014/30/EU)

- EN 55014-1:2021

- EN 55014-2:2021

- EN 61000-3-2:2019

- EN 61000-3-3: 2013

PT Declaração de Conformidade

A Nilfisk FOOD declara sob sua única responsabilidade que os produtos **MA2iM, MA3iM, MA2i, MA3i, MA2, MA3, MA2M, MA3M, SA2iM, SA3iM, SA2i, SA3i**, aos quais diz respeito esta declaração, estão em conformidade com as seguintes Directivas do Conselho sobre a aproximação das legislações dos Estados Membros da CE: Directiva Máquinas (2006/42/EC).

- EN 60335-2-79:2012

Directiva EMC (2014/30/EU)

- EN 55014-1:2021

- EN 55014-2:2021

- EN 61000-3-2:2019

- EN 61000-3-3: 2013

NL Verklaring van overeenstemming

Wij, Nilfisk FOOD, verklaren geheel onder eigen verantwoordelijkheid dat de producten **MA2iM, MA3iM, MA2i, MA3i, MA2, MA3, MA2M, MA3M, SA2iM, SA3iM, SA2i, SA3i**, waarop deze verklaring betrekking heeft, in overeenstemming zijn met de Richtlijnen van de Raad in zake de onderlinge aanpassing van de wetgeving van de EG Lidstaten betreffende:

Machine Richtlijn (2006/42/EC).

- EN 60335-2-79:2012

EMC Richtlijn (2014/30/EU).

- EN 55014-1:2021

- EN 55014-2:2021

- EN 61000-3-2:2019

- EN 61000-3-3: 2013

- EN 61000-3-3: 2013

SV Försäkran om överensstämmelse

Vi, Nilfisk FOOD, försäkrar under ansvar att produkterna **MA2iM, MA3iM, MA2i, MA3i, MA2, MA3, MA2M, MA3M, SA2iM, SA3iM, SA2i, SA3i**, som omfattas av denna försäkran, är i överensstämmelse med rådets direktiv om inbördes närmande till EU-medlemsstaternas lagstiftning, avseende:

Maskindirektivet (2006/42/EG).

- EN 60335-2-79:2012

EMC-direktivet (2014/30/EU).

- EN 55014-1:2021

- EN 55014-2:2021

- EN 61000-3-2:2019

- EN 61000-3-3: 2013

DA Overensstemmelseserklæring

Vi, Nilfisk FOOD, erklærer under ansvar at produkterne **MA2iM, MA3iM, MA2i, MA3i, MA2, MA3, MA2M, MA3M, SA2iM, SA3iM, SA2i, SA3i**, som denne erklæring omhandler, er i overensstemmelse med disse af Rådets direktiver om indbyrdes tilnærmelse til EF-medlemsstaternes lovgivning:

Maskindirektivet (2006/42/EF).

- EN 60335-2-79:2012

EMC-direktivet (2014/30/EU).

- EN 55014-1:2021

- EN 55014-2:2021

- EN 61000-3-2:2019

- EN 61000-3-3: 2013

RU Декларация соответствия

Мы, компания Nilfisk FOOD, со всей ответственностью заявляем, что изделия **MA2iM, MA3iM, MA2i, MA3i, MA2, MA3, MA2M, MA3M, SA2iM, SA3iM, SA2i, SA3i**, к которым относится настоящая декларация, соответствуют следующим Директивам Совета Евросоюза об унификации законодательных предписаний стран-членов ЕС:

Механические устройства (2006/42/ЕС).

- EN 60335-2-79:2012

Электромагнитная совместимость (2014/30/EU)

- EN 55014-1:2021

- EN 55014-2:2021

- EN 61000-3-2:2019

- EN 61000-3-3: 2013

SL Izjava o skladnosti

V Nilfisk FOODu s polno odgovornostjo izjavljamo, da so naši izdelki **MA2iM, MA3iM, MA2i, MA3i, MA2, MA3, MA2M, MA3M, SA2iM, SA3iM, SA2i, SA3i**, na katere se ta izjava nanaša, v skladu z naslednjimi direktivami Sveta o približevanju zakonodaje za izenačevanje pravnih predpisov držav članic ES:

Direktiva o strojih (2006/42/ES).

- EN 60335-2-79:2012

Direktiva o elektromagnetni združljivosti (EMC) (2014/30/EU).

- EN 55014-1:2021

- EN 55014-2:2021

- EN 61000-3-2:2019

- EN 61000-3-3: 2013

FI Vaatimustenmukaisuusvakuutus

Me, Nilfisk FOOD, vakuutamme omalla vastuullamme, että tuotteet **MA2iM, MA3iM, MA2i, MA3i, MA2, MA3, MA2M, MA3M, SA2iM, SA3iM, SA2i, SA3i**, joita tämä vakuutus koskee, ovat EY:n jäsenvaltioiden lainsäädännön yhdenmukaistamiseen tähtäävien Euroopan neuvoston direktiivien vaatimusten mukaisia seuraavasti:

Konedirektiivi (2006/42/EY).

- EN 60335-2-79:2012

EMC-direktiivi (2014/30/EU).

- EN 55014-1:2021

- EN 55014-2:2021

- EN 61000-3-2:2019

- EN 61000-3-3: 2013

PL Deklaracja zgodności

My, Nilfisk FOOD, oświadczamy z pełną odpowiedzialnością, że nasze wyroby **MA2iM, MA3iM, MA2i, MA3i, MA2, MA3, MA2M, MA3M, SA2iM, SA3iM, SA2i, SA3i**, których deklaracja niniejsza dotyczy, są zgodne z następującymi wytycznymi Rady d/s ujednolicenia przepisów prawnych krajów członkowskich WE:

Dyrektywa Maszynowa (2006/42/WE).

- EN 60335-2-79:2012

Dyrektywa EMC (2014/30/EU).

- EN 55014-1:2021

- EN 55014-2:2021

- EN 61000-3-2:2019

- EN 61000-3-3: 2013

HU Megfelelőségi nyilatkozat

Mi, Nilfisk FOOD, izjavljujemo pod vlastitom odgovornostu da je proizvod **MA2iM, MA3iM, MA2i, MA3i, MA2, MA3, MA2M, MA3M, SA2iM, SA3iM, SA2i, SA3i**, na koji se ova izjava odnosi, u skladu s direktivama ovog Vijeća o usklađivanju zakona država članica EU:

Direktiva za strojeve (2006/42/EZ).

- EN 60335-2-79:2012

Direktiva za elektromagnetsku kompatibilnost (2014/30/EU).

- EN 55014-1:2021

- EN 55014-2:2021

- EN 61000-3-2:2019

- EN 61000-3-3: 2013

HR Izjava o usklađenosti

Mi, Nilfisk FOOD, izjavljujemo pod vlastitom odgovornostu da je proizvod **MA2iM, MA3iM, MA2i, MA3i, MA2, MA3, MA2M, MA3M, SA2iM, SA3iM, SA2i, SA3i**, na koji se ova izjava odnosi, u skladu s direktivama ovog Vijeća o usklađivanju zakona država članica EU:

Direktiva za strojeve (2006/42/EZ).

- EN 60335-2-79:2012

Direktiva za elektromagnetsku kompatibilnost (2014/30/EU).

- EN 55014-1:2021

- EN 55014-2:2021

- EN 61000-3-2:2019

- EN 61000-3-3: 2013

SR Deklaracija o konformitetu

Mi, Nilfisk FOOD, izjavljujemo pod vlastitom odgovornošću da je proizvod **MA2iM, MA3iM, MA2i, MA3i, MA2, MA3, MA2M, MA3M, SA2iM, SA3iM, SA2i, SA3i**, na koji se ova izjava odnosi, u skladu sa direktivama, Saveta za usklađivanje zakona država članica EU:

Direktiva za mašine (2006/42/EC).

- EN 60335-2-79:2012

EMC direktiva (2014/30/EU).

- EN 55014-1:2021

- EN 55014-2:2021

- EN 61000-3-2:2019

- EN 61000-3-3: 2013

RO Declarație de conformitate

Noi, Nilfisk FOOD, declarăm pe propria răspundere că produsele **MA2iM, MA3iM, MA2i, MA3i, MA2, MA3, MA2M, MA3M, SA2iM, SA3iM, SA2i, SA3i**,

la care se referă această declarație, sunt în conformitate cu aceste Directive de Consiliu asupra armonizării legilor Statelor Membre CE: Directiva Utilaje (2006/42/CE).

- EN 60335-2-79:2012

Directiva EMC (2014/30/EU)

- EN 55014-1:2021

- EN 55014-2:2021

- EN 61000-3-2:2019

- EN 61000-3-3: 2013

BG Декларация за съответствие

Ние, фирма Nilfisk FOOD, заявяваме с пълна отговорност, че продуктите **MA2iM, MA3iM, MA2i, MA3i, MA2, MA3, MA2M, MA3M, SA2iM, SA3iM, SA2i, SA3i**, за които се отнася настоящата декларация, отговарят на следните указания на Съвета за уеднаквяване на правните разпоредби на държавите членки на ЕС:

Директива за машините (2006/42/EC).

- EN 60335-2-79:2012

Директива за електромагнитна съвместимост (2014/30/EU).

- EN 55014-1:2021

- EN 55014-2:2021

- EN 61000-3-2:2019

- EN 61000-3-3: 2013

CS Prohlášení o shodě

My firma Nilfisk FOOD prohlašujeme na svou plnou odpovědnost, že výrobky **MA2iM, MA3iM, MA2i, MA3i, MA2, MA3, MA2M, MA3M, SA2iM, SA3iM, SA2i, SA3i**, na něž se toto prohlášení vztahuje, jsou v souladu s ustanoveními směrnice Rady pro sblížení právních předpisů členských států Evropského společenství v oblastech: Směrnice pro strojní zařízení (2006/42/ES).

- EN 60335-2-79:2012

Směrnice pro elektromagnetickou kompatibilitu (EMC) (2014/30/EU)

- EN 55014-1:2021

- EN 55014-2:2021

- EN 61000-3-2:2019

- EN 61000-3-3: 2013

SK Prehlásenie o zhode

My firma Nilfisk FOOD prehlasujeme na svoju plnú zodpovednosť, že výrobky **MA2iM, MA3iM, MA2i, MA3i, MA2, MA3, MA2M, MA3M, SA2iM, SA3iM, SA2i, SA3i**, na ktoré sa toto prehlásenie vzťahuje, sú v súlade s ustanovením smernice Rady pre zblíženie právnych predpisov členských štátov Európskeho spoločenstva v oblastiach: Smernica pre strojové zariadenie (2006/42/EC).

- EN 60335-2-79:2012

Smernica pre elektromagnetickú kompatibilitu (2014/30/EU).

- EN 55014-1:2021

- EN 55014-2:2021

- EN 61000-3-2:2019

- EN 61000-3-3: 2013

TR Uygunluk Beyanı

Nilfisk FOOD olarak bu beyannameye konu olan **MA2iM, MA3iM, MA2i, MA3i, MA2, MA3, MA2M, MA3M, SA2iM, SA3iM, SA2i, SA3i**, ürünlerinin, AB Üyesi Ülkelerin kanunlarını birbirine yaklaştıranma üzere Konsey Direktifleriyle uyumlu olduğunun yalnızca bizim sorumluluğumuz altında olduğuna beyan ederiz: Makineler Yönetmeliği (2006/42/EC).

- EN 60335-2-79:2012

EMC Direktifi (2014/30/EU).

- EN 55014-1:2021

- EN 55014-2:2021

- EN 61000-3-2:2019

- EN 61000-3-3: 2013

ET Vastavusdeklaratsioon

Meie, Nilfisk FOOD, deklareerime enda ainuvastutusel, et tooted **MA2iM, MA3iM, MA2i, MA3i, MA2, MA3, MA2M, MA3M, SA2iM, SA3iM, SA2i, SA3i**, mille kohta käesolev juhend käib, on vastavuses EÜ Nõukogu direktiividega EMÜ liikmesriikide seaduste ühitamise kohta, mis käsitlevad: Masinate ohutus (2006/42/EC).

- EN 60335-2-79:2012

Elektromagnetilise ühilduvus (EMC direktiiv) (2014/30/EU).

- EN 55014-1:2021

- EN 55014-2:2021

- EN 61000-3-2:2019

- EN 61000-3-3: 2013

LT Atitikties deklaracija

Kompanija Nilfisk FOOD заявляє про свою виключну відповідальність за те, що продукти **MA2iM, MA3iM, MA2i, MA3i, MA2, MA3, MA2M, MA3M, SA2iM, SA3iM, SA2i, SA3i**, на які поширюється дана декларація, відповідають таким рекомендаціям Ради з уніфікації правових норм країн -членів ЕС:

Механічні прилади (2006/42/EC).

- EN 60335-2-79:2012

Електромагнітна сумісність (2014/30/EU).

- EN 55014-1:2021

- EN 55014-2:2021

- EN 61000-3-2:2019

- EN 61000-3-3: 2013

LV Atbilstības deklarācija

Sabiedrība NILFISK FOOD ar pilnu atbildību dara zināmu, ka produkti **MA2iM, MA3iM, MA2i, MA3i, MA2, MA3, MA2M, MA3M, SA2iM, SA3iM, SA2i, SA3i**, uz kuriem attiecas šis paziņojums, atbilst šādām Padomes direktīvām par tuvināšanos EK dalībvalstu likumdošanas normām:

Mašīnbūves direktīva (2006/42/EK).

- EN 60335-2-79:2012

Elektromagnētiskās saderības direktīva (2004/108/EK).

- EN 55014-1:2021

- EN 55014-2:2021

- EN 61000-3-2:2019

- EN 61000-3-3: 2013

UK Свідчення про відповідність

ВИМОГАМ

Компанія Nilfisk FOOD заявляє про свою виключну відповідальність за те, що продукти **MA2iM, MA3iM, MA2i, MA3i, MA2, MA3, MA2M, MA3M, SA2iM, SA3iM, SA2i, SA3i**, на які поширюється дана декларація, відповідають таким рекомендаціям Ради з уніфікації правових норм країн -членів ЕС:

Механічні прилади (2006/42/EC).

- EN 60335-2-79:2012

Електромагнітна сумісність (2004/108/EC).

- EN 55014-1:2021

- EN 55014-2:2021

- EN 61000-3-2:2019

- EN 61000-3-3: 2013

Technical file responsible:

Flemming Asp

Nilfisk FOOD

Blytækkervej 2

9000 Aalborg, Denmark

Signature:



Flemming Asp

R & D Manager













Aalborg d. 01-03-2023

1. Contents

2. Document symbols	9
3. General information	10
3.1. MA	10
3.2. SA	10
3.3. Identification plate	11
3.4. Supplier	11
3.5. Specifications	12
4. Safety	13
4.1. Operation safety	13
4.2. Product safety	13
4.3. Emergency shutdown	14
4.3.1. Turn off the power supply	14
4.3.2. Closing valve for water supply	14
4.3.3. Closing valve for air supply	14
4.4. Noise	14
4.5. Vibrations	14
4.6. Anticipated failures and precautions	14
4.6.1. Bursted air tube in unit	14
4.6.2. Breakdown of non-return valves for air and water	14
4.7. Residual risk	14
4.7.1. Damaged unit	14
4.7.2. Repair of unit	14
5. Transportation & installation	15
5.1. Transportation	15
5.2. Installation preparations	15
5.3. Mounting Instructions	15
5.4. Electrical installation	15
5.4.1. Power supply	15
5.4.2. Earth leakage circuit breaker (ELCB)	15
5.4.3. Service switch	15
5.5. I/O Modules	15
5.6. Water connection	15
5.7. Air connection	16
5.8. Supply of product	16
5.8.1. User pack system	16
5.8.2. Can holder system	16
5.8.3. Use of Direct Chemical Injection (DI)	17
5.9. Hose connection	17
6. System preparation	18
6.1. Start up of new system	18
6.2. Bleeding guidelines	18
6.2.1. Bleeding the pipe system	18
6.2.2. Bleeding the pump (MA only)	18
6.3. Adjustments	18
6.3.1. Instruction and setup	18
6.3.2. Adjustment of air	18
6.3.3. Adjustment of product - manual block	18
6.3.4. Adjustment of product - automatic block	18

7. Operation	20
7.1. Start/Stop	20
8. Maintenance, troubleshooting & service	21
8.1. Maintenance personnel	21
8.2. Long production stops	21
8.3. Components	21
8.3.1. Control system	21
8.3.2. Flow switch	21
8.3.3. Pump/motor	21
8.3.4. Product solenoid valve	21
8.4. Preventive/regular maintenance	22
8.4.1. Rinsing the product supply/injector system	22
8.4.2. Change of injector	22
8.4.3. Delimiting	22
8.4.4. Coupling	22
8.4.5. Internal cleaning of the unit	22
8.5. Trouble shooting and remedy	23
8.6. Service address	23
9. End of Use	24
9.1. Dismounting	24
9.2. Disposal	24
10. Spare part list	25
10.1. MA overview	26
10.2. SA overview	28
10.3. Manual block	30
10.4. Automatic block	32
10.5. Inlet & outlet pipe MA	34
10.6. Inlet & outlet pipe SA	36
10.7. Product solenoid valve	38
10.8. Controller with display	40
11. Sensors & diagrams MA	43
11.1. Operating Diagram MA	44
11.2. Electrical ratings MA	45
11.3. Component location MA	46
11.4. Circuit diagrams & sensor diagrams MA2IM, MA3IM, MA2I, MA3I	47
11.5. Pump curve	63
12. Sensors & diagrams SA	65
12.1. Operating Diagram SA	66
12.2. Electrical ratings SA	67
12.3. Component location SA	68
12.4. Circuit diagrams & sensor diagrams SA	69
13. Installation, mounting & layout	75
13.1. Installation & mounting MA	76
13.2. Vertical Adjustment MA	77
13.3. Installation & mounting SA	78
13.4. Layout MA	79
13.5. Layout SA	80

2. Document symbols

	<p>Read before use.</p>		<p>Danger: Warning! Sharp edges – watch your fingers.</p>
	<p>Wear glasses when using the unit.</p>		<p>Hot Surfaces Risk of burns! Possible consequences: Severe injuries.</p>
	<p>Wear gloves and suitable clothing when using the unit.</p>		<p>Power off The device may be powered for up to 180 seconds after the main power supply has been disconnected.</p>
	<p>Safety boots must be worn.</p>		
	<p>Note: A potentially damaging situation. Possible consequences: The product or something in its vicinity could be damaged. Prevention.</p>		
	<p>Caution: A dangerous situation. Possible consequences: light or minor injuries. Can also be used to warn against damage to property or other goods prevention.</p>		
	<p>Warning: A Potentially dangerous situation. Possible consequences: Death or severe injury.</p>		
	<p>Danger: A dangerous situation. Possible consequences: Death or severe injury.</p>		
	<p>Danger: Risk of electric shock! Possible consequences: Death or severe injury.</p>		

3. General information

Nilfisk FOOD congratulates you on your new low-pressure foam and sanitising cleaning equipment.

The equipment provides the latest standard of technology in low pressure cleaning equipment in your factory.

The equipment can be used for rinsing, foaming and application of disinfectants.

It is important that your operational staff read these directions for use prior to installation, start up and use of the equipment.

3.1. MA

The Hybrid 7 mainstations are fully functional hygiene and pumping systems that supply pressurized water to the integrated hygiene points (optional) and multiple connected cleaning areas.

It features a frequency-controlled pump that ensures consistent working pressure, regardless of usage.

To operate, the mainstation must be supplied with sufficient water, power, compressed air, and product(s).

3.2. SA

The Hybrid 7 satellites are cleaning units that supply pre-pressurized water to the integrated hygiene points (optional) and several connected cleaning areas.

To operate, the satellite must be supplied with sufficient pressurized water, power, compressed air, and product(s).

3.3. Identification plate

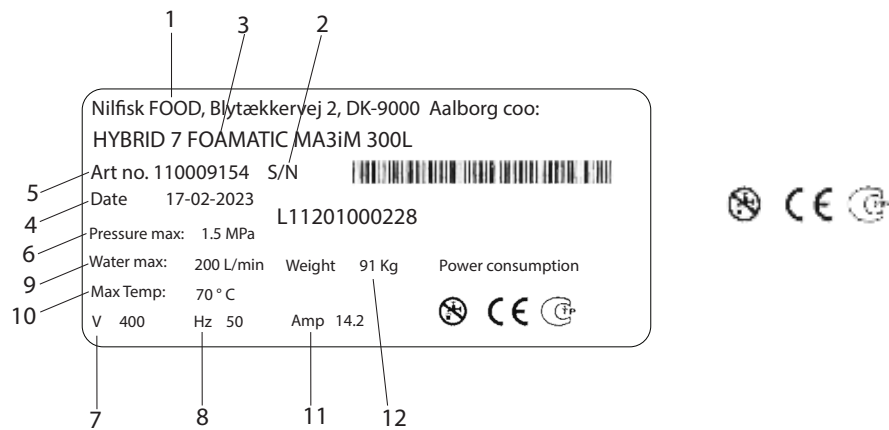

- 1. Producer
- 2. Serial no
- 3. Type
- 4. Date of production
- 5. Article no
- 6. Maximum pressure
- 7. Supply voltage
- 8. Frequency
- 9. Maximum water consumption
- 10. Maximum temperature
- 11. Current
- 12. Weight

3.4. Supplier

Nilfisk FOOD
 Blytækkervej 2
 DK-9000 Aalborg, Denmark
 Tel.: +45 2969 5100
 CVR no. 6257 2213
 www.nilfiskfood.com

3.5. Specifications

General	Unit	MA	SA
Sound level ISO 11202	dB	<70	<70
Dimensions HxWxD	mm [inches]	1260x560x400 [49x22x15]	530 x 400 x 140 [21x15x6]
Weight	kg [lbs]	96 [211]	40 [88]
IP class		55	55
Water			
Max.outlet pressure.	MPa (bar)[psi]	1.5 (15) [217]	Max. supply pressure
Consumption during rinsing (manual)	L/min [gal/min]	30 [7.9]	30 [7.9]
Consumption during foaming (manual)	L/min [gal/min]	8 [2.1]	1.2 [0.3]
Consumption during rinsing max. (automatic)	L/min [gal/min]	200 [52]	
Consumption during foaming (automatic) @15 bar	L/min [gal/min]	8/16/24 [2/4/6]	8/16/24 [2/4/6]
Min. supply pressure	MPa (bar) [psi]	0.2 (2) [29]	0.7 (7) [101]
Max. supply pressure	MPa (bar) [psi]	0.8 (8) [116]	2.5 (25) [363]
Min. water supply	L/min [gal/min]	200 [52]	
Max water temperature	°C [°F]	70 [158]	70 [158]
Pipe dimension inlet Ø	mm [inches]	38 [1.49]	38 [1.49]
Pipe dimension outlet Ø	mm [inches]	38 [1.49]	38 [1.49]
Clamp connection type/size (Ferrole)	Type/mm	DS-SMS/ø50,4	DS-SMS/ø50,4
Electricity			
Supply voltage	V	3/PE 380-528Vac	3/PE 380-528Vac
Frequency	Hz	50/60Hz	50/60Hz
Motor load (kW)	kW	5.5	
Max total load (kW)	kW	6	0.5
Nominal current	A	14.2	1
Fuse	A	20	13
Internal fuse 5x20mm - 400V	A	1 slow blow	1 slow blow
L1, L2, L3, PE	mm ²	2.5	1.5
Air			
Min/max air pressure.	Mpa (bar) [psi]	0,6-1 (6-10) [87-145]	0,6-1 (6-10) [87-145]
Compressed air consumption.	l/min [gal/min]	300 [79]	300 [79]
Pipe dimension inlet Ø.	mm	8	8

4. Safety

4.1. Operation safety



Wear glasses when using the unit.



Wear gloves and suitable clothing when using the unit.



Safety boots must be worn.

- Never use the unit without proper training sessions on the unit's use and safety instructions. The training must be provided by an educated personnel.
- Read the enclosed guide and safety instructions before use.



CAUTION:

The unit might be hot. Ensure sufficient cooling time.



WARNING:

Do not use the unit within range of persons unless they wear protective clothing.



WARNING:

The spray jets can be dangerous if subjected to misuse. The jets must not be directed at persons, live electrical equipment or the unit itself.



WARNING: Do not use the water from the system for applications other than cleaning.

4.2. Product safety:

- The unit is approved for the use of products and disinfectants.



WARNING:

Risk of chemical residue. Wear protective clothing.

- Product can be supplied through User Pack, standard cans, or piping systems. Refer to section 5.8 for further information.
- Follow safety procedures when handling chemicals during product change, maintenance, or repair. Refer to product labels and MSDS for more information.



WARNING: Do not alter settings made or recommended by the product supplier.



WARNING: Be aware that mixing of products during use can lead to a dangerous chemical reaction potentially dangerous to the user.



WARNING:

This machine has been designed for use with the cleaning agents supplied or recommended by the supplier.



CAUTION

The product supply must always be rinsed thoroughly after use.

- For instructions on rinsing product supply, refer to Section 8.4.1.

4.3. Emergency shutdown

	<p>DANGER: In case of error/defect or service on equipment:</p> <ol style="list-style-type: none"> 1. Turn off power supply. 2. Close the water supply. 3. Close the air supply.
---	--

4.3.1. Turn off the power supply

- Turn off the power supply to the unit.
- (MA only) Turn off the inverter. The inverter can be shut down by turning the button to a vertical position (refer to image below).



4.3.2. Closing valve for water supply.

- With this valve the unit can be isolated from the water supply.
- A non-return valve is built into the unit to prevent water backflow.

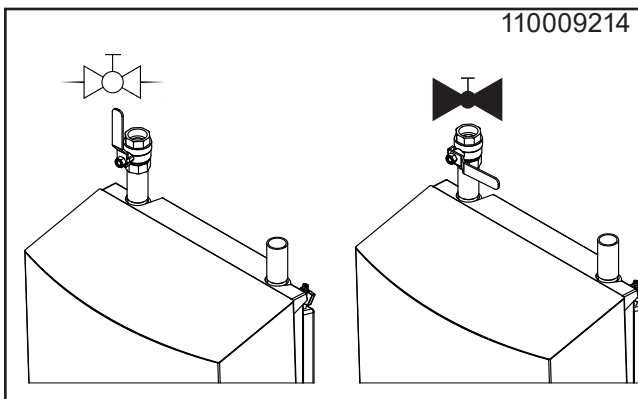

4.3.3. Closing valve for air supply

- This valve can isolate the unit from the water supply.
- Non-return valves are built into the unit to prevent air backflow.

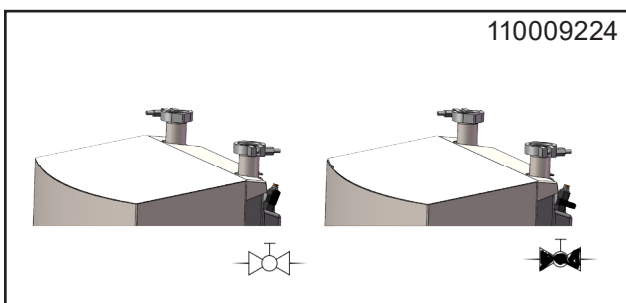

4.4. Noise

Sound level according to ISO 11202: Below 70dB.

4.5. Vibrations

Hand-arm vibrations according to ISO 5349-1.

4.6. Anticipated failures and precautions

4.6.1. Bursted air tube in unit:

- Ensure front cover is mounted and air valve is closed when not in use.
- Regularly inspect air tube and fitting and replace if damaged.

4.6.2. Breakdown of non-return valves for air and water:

- Unit cover must be mounted during use.
- Close air and water valves when not in use.
- Rinse all product non-return valves after use (refer to section 8.4.1.)
- Examine air and water non-return valves once a year by authorized personnel.

4.7. Residual risk

4.7.1. Damaged unit:

- Do not use if isolation valves cannot be operated or required operation cannot be selected.
- Never use the unit if it has been dislodged from its original place of mounting.

4.7.2. Repair of unit:

- Do not attempt to repair a unit by yourself. Always contact an authorized service company. Refer to the back of the manual for service addresses.
- Block and mark any defect unit in order to avoid unintended use.
- For safety reasons only use approved and original spare parts.

5. Transportation & installation

5.1. Transportation

- Secure the unit with straps to prevent sliding or tipping during transport.
- Transport the unit only in a horizontal position.
- Do not place the unit on the front where the control panel is located, or on the top or bottom where connections and outlets are located.
- If the unit is moved when the temperature is near or below 0°C (32°F), make sure it is fully emptied of water to avoid damage.

5.2. Installation preparations

- Read all the included information for safety reasons before installing the equipment.
- Follow the applicable laws and regulations at the time of purchase, in addition to this manual.
- Installation must always be in accordance with local legislation.
- Consider leaving at least 1m free space around the unit for easier maintenance.
- Ensure sufficient wall space for additional I/O module brackets if installing them (refer to the I/O installation manual).
- Rinse the pipeline thoroughly before connecting the unit.

5.3. Mounting Instructions

For safe mounting, note the following:

- Only install the unit in a frost-free area.
- Remove the cover before mounting the unit on the wall.
- Use a stable brick or concrete wall, or a separate frame anchored to the floor.
- Refer to the installation drawing for recommended installation height. The height can be adjusted for the operator's reach to valves and display.
- Mount the bracket on a stable brick or concrete wall using the enclosed screws and rawplugs.
- If the wall is not made of bricks or concrete, ensure it can support the weight of the unit.
- Hang the unit on the bracket and secure it with two screws through designated holes.
- Secure the unit in the top by two screws through the designated holes. Refer to installation drawings in section 13.1 and 13.3.
- Mount the hose holder and user pack holder if any.

5.4. Electrical installation

Refer to section 11 and section 13 for electrical diagrams and ratings.

5.4.1. Power supply

Connection instruction is mounted on the cables. The phase order is subordinated.

5.4.2. Earth leakage circuit breaker (ELCB).

- Use an earth leakage circuit breaker (ELCB), also known as a residual current device (RCD) or a residual current circuit breaker (RCCB), in a system that includes a variable speed drive connected to 3 phase 400V.
- The trip level of the ELCB must be 300mA.
- Note that the 30mA used in households can malfunction due to earth leakage (MA only).

5.4.3. Service switch

The unit must always be connected to the main supply through a separate service switch.

	MAxxx	SAxxx
Voltage:	3/PE 380-528Vac	3/PE 380-528Vac
Frequenz:	50/60 Hz 48-62	50/60 Hz 48-62
Motor load:	5.5 kW	-
Total load	6 kW	0,5 kW
Nominal current:	14.2 A	1 A
Fuse:	20 A	16 A
L1, L2, L3, PE	2.5 mm ²	1.5 mm ²

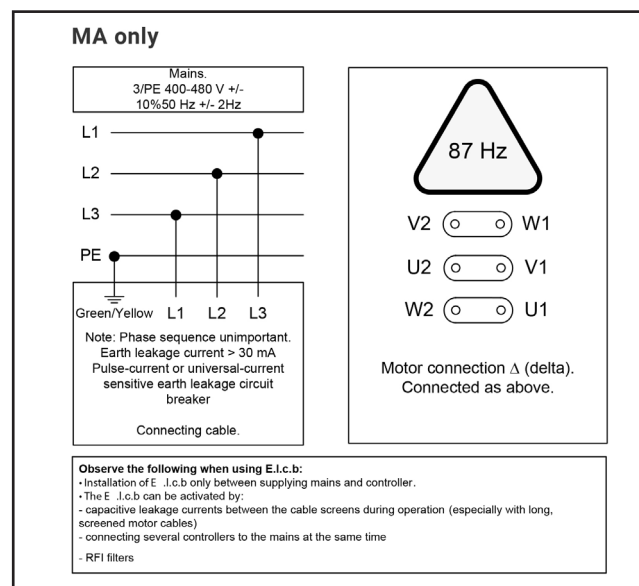

5.5. I/O Modules

For instructions on installation of additional I/O modules, refer to the Hybrid 7 I/O module installation manual.

5.6. Water connection

For technical specifications on water supply, refer to section 3.5.

- Before the unit is connected to the water supply pipe, the supply line should be rinsed thoroughly in order to remove coarse impurities and metal shavings.

- When installing piping, avoid air traps. Use clamp connections for all pipe connections to the unit for easy maintenance and disassembly.
- The connection for water must be made at the top of the unit. Refer to layout drawing in section 13.4 and 13.6.
- Minimum diameter of the supply pipe must be at least Ø38 external (ø35mm internal).
- The unit must be fitted with a closing valve for water on the inlet (see image 110009214 page 14).
- For best performance, install a filter on the inlet to prevent impurities (refer to image below).

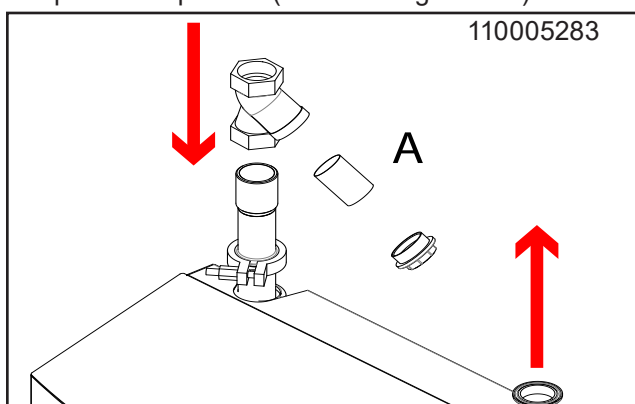

To minimize pressure loss in the supply line:

- Avoid long pipe lines.
- Use low pressure resistance ball valves.
- Avoid fittings with high pressure loss.

5.7. Air connection

For technical specifications on air supply, refer to section 3.5.

- Before the unit is connected to the air supply, the pipe system must be carefully rinsed in order to remove coarse impurities.
- The unit requires an air supply boosting.
- The air inlet of the system has quick connect fittings.

5.8. Supply of product

- It is important to rinse the system with clean water between product changes and after use for safety and maintenance reasons. Refer to the rinsing guides below and section 8.4 for advanced maintenance.

5.8.1. User pack system

Installing a user pack:

1. Insert the user pack in the holder.
2. Use a foam nozzle and open the spray gun/valve

Rinsing the system:

Refer to image 110005307.

1. Replace the user pack containing product with one containing clean water.
2. Use a foam nozzle and open the spray gun/valve for 20 seconds to rinse the system.
3. The system is now ready to be used with a new product.

5.8.2. Can holder system

Refer to image 110005307.

Installing a can:

1. Insert the can in the holder.
2. Check the suction filter for impurities
3. Put the suction hose into the can below the product level to avoid suction of air into the product hose.
4. Use a foam nozzle and open the spray gun/valve.
5. Ensure the hose is below the product level during foam or spray operation.

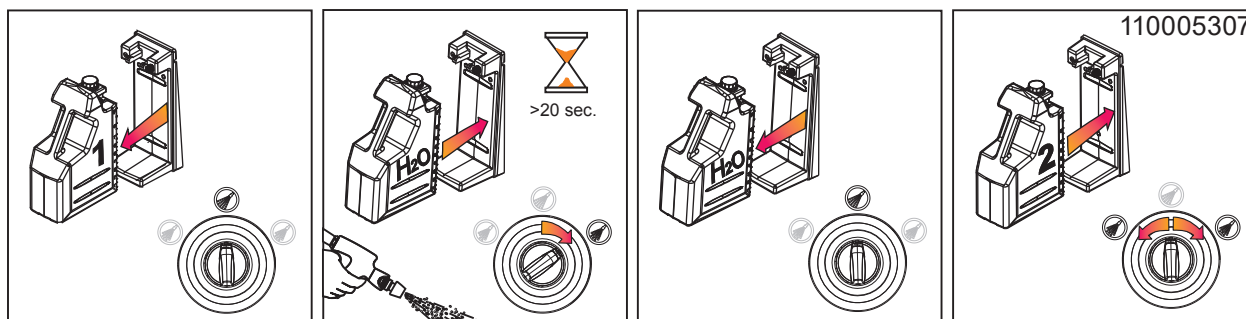
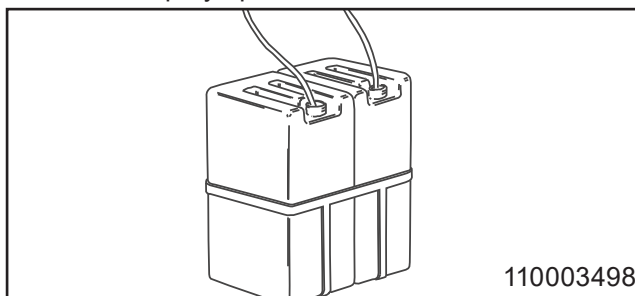

Rinsing the system:

1. Replace the can containing product with one containing clean water.
2. Use a foam nozzle and open the spray gun/valve for 20 seconds to rinse the system.
3. The system is now ready to be used with a new product.

5.8.3. Use of Direct Chemical Injection (DI)

- It is possible to use the unit with direct piping system.
- Refer to the installation and safety instructions provided by the supplier for proper installation.

5.9. Hose connection

- The special hose fitted with spray gun/outlet valve is connected to the outlet quick coupling of the unit (refer to layout drawing).
- Maximum hose length: 30 m.
- It is recommended only to use Nilfisk FOOD hoses, which have been tested for resistance.

6. System preparation

6.1. Start up of new system

To ensure smooth start-up of the new system, follow these guidelines.

6.2. Bleeding guidelines

6.2.1. Bleeding the pipe system

- Close water and air supply after use.
- Leaving the air supply open may allow air to enter the water pipe.
- Regular bleeding may be necessary after prolonged shutdowns.

6.2.2. Bleeding the pump (MA only)

- Start the pump to force any remaining air pockets to the top of the pump.
- Stop the pump.
- Loosen the relief plug 1-2 turns again and bleed until only water flows.
- Tighten the relief plug.
- Never loosen the relief plug while the pump is in operation as this may damage the gasket.

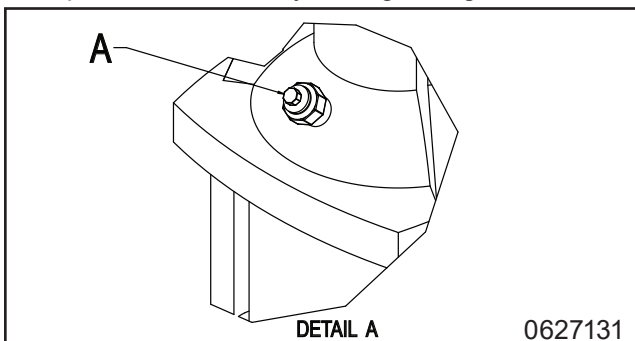

- The mainstation is now ready for use.

6.3. Adjustments

6.3.1. Instruction and setup

Refer to the user guide for general machine operation instructions.

Refer to the software manual for guidance on setting up automatic wash programs and area valves.

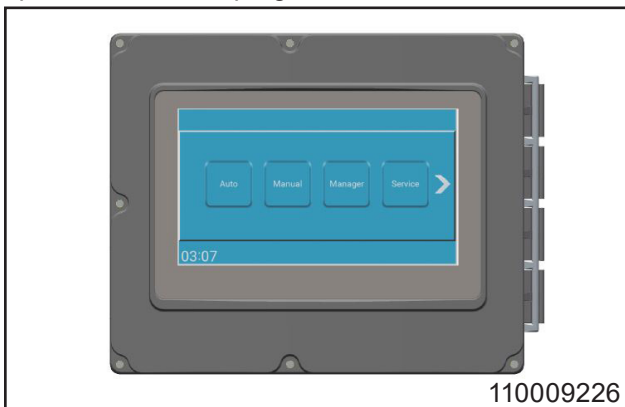

6.3.2. Adjustment of air

To adjust air, remove the unit cover and set air pressure on the reduction valve for desired foam quality.



When setting the regulator, carefully pull up the knob and turn it clockwise for pressure increase and counter clockwise for pressure decrease.

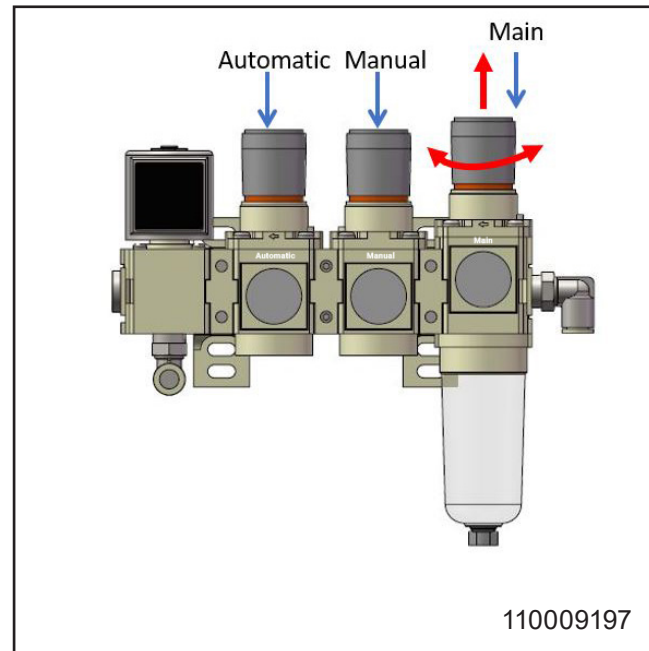

6.3.3. Adjustment of product - manual block

Adjust product for the manual block by using a limiting nozzle located in the suction nipple of the non-return valve (image 110009231).

- Remove the unit cover.
- Replace the nozzle with a smaller or larger one to adjust concentration. Refer to the table for guidance.

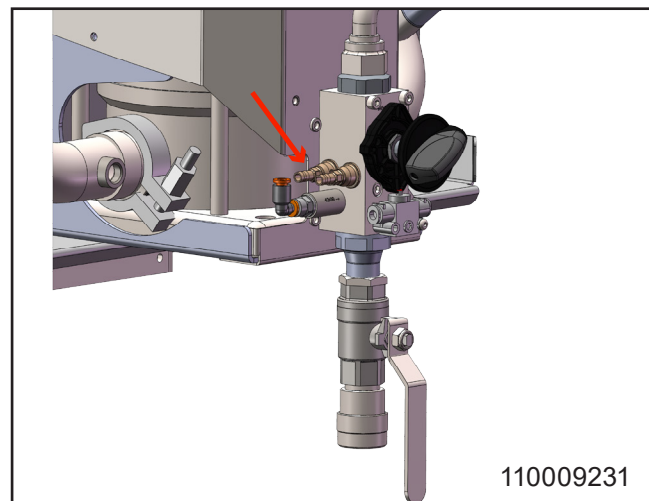



Nozzle colour	Concentration by 20 Bar /290PSI	mm	Inch
Light blue	0.64%	0.3	0.012
Turquios	1.07%	0,4	0.016
Yellow	1.79%	0.5	0.020
Orange	2.36%	0.6	0.024
Green	3.15%	0.7	0.028
Black	4.26%	0.8	0.032
Beige	5.05 %	0.9	0.036
Blå	6,12%	1.1	0.044
White	7.00%	1.3	0.052
Red	7.35%	1.5	0.060

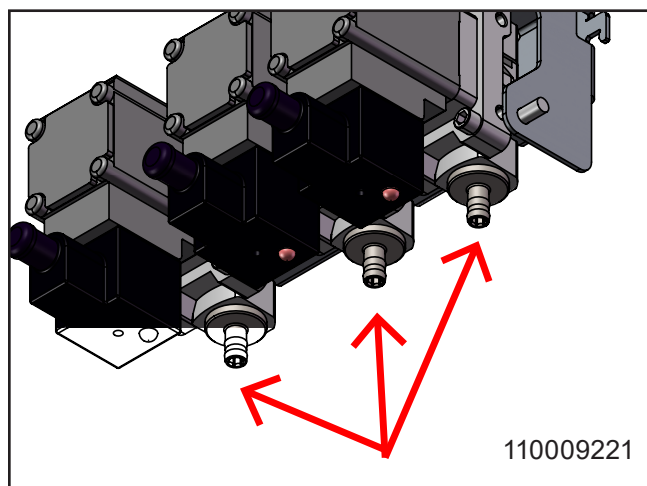

6.3.4. Adjustment of product - automatic block

Adjust product for the automatic block by using a limiting nozzle located in the suction nipple of the solenoid valve (image 110009221).

- Remove the unit cover.
- Replace the nozzle with a smaller or larger one to adjust concentration. Refer to the table for guidance.

7. Operation



Wear glasses when using the unit.



Wear gloves and suitable clothing when using the unit.



Safety boots must be worn.

- Refer to the user guide for general machine operation instructions.
- Refer to the software manual for guidance on setting up automatic wash programs and area valves.
- Only trained personnel are allowed to operate this unit. Refer to section 4.1 for operation safety guidelines.

7.1. Start/Stop

- Close water and air supply after use.
- Rinse product supply after use (refer to section 8.4.1).

Start

1. Verify that water and air supplies for the system are open.
2. Ensure water and air supply to unit is open.
3. If using direct piping for product supply, ensure that the supply is activated.
4. Select the desired function and follow the instructions provided in the user guide.

Stop

1. Stop the system by pressing the relevant button on the control display (refer to image below).

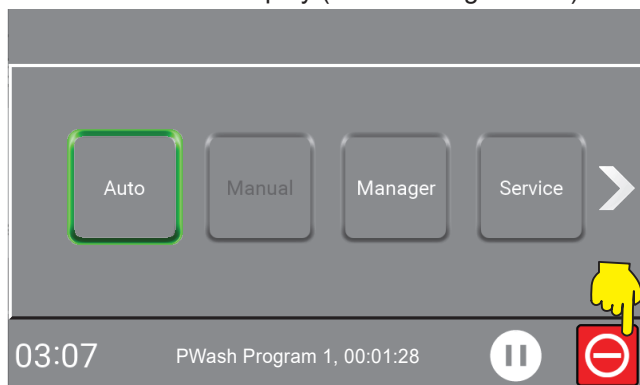

2. Turn off the water supply.
3. Close the air supply.
4. Deactivate the product supply by lifting the suction hose, removing the user pack, or turning off the direct piping system.

8. Maintenance, troubleshooting & service



Service may only be carried out by authorized and qualified personnel.

8.1. Maintenance personnel

Maintenance should be performed by an authorized service engineer at least once a year to ensure proper operation and prevent defects. Authorized engineers must have knowledge of hygiene systems, safety regulations, and national technical standards.

This cleaning unit is compliant with EU regulations and has a CE marking. Contact the service department for more information (see back of manual).

8.2. Long production stops

For production stops exceeding 6 months, empty and secure the pump:

1. Remove the coupling safety guard.
2. Apply a few drops of silicone oil to the axle between the top section and the coupling.

Follow pump supplier manual instructions carefully. Do not store or use the equipment in below freezing temperature.

8.3. Components

8.3.1. Control system

No maintenance needed.

If defective: Call a service technician.

8.3.2. Flow switch

No maintenance needed.

If defective, replace the flow switch.

Flow switch installation

- Ensure the dot on the sensor nut indicating the contact point is within 30° parallel to the flow direction (refer to image below).
- The factory uses threadlocker to secure the thread, but packing yarn or tape can also be used.

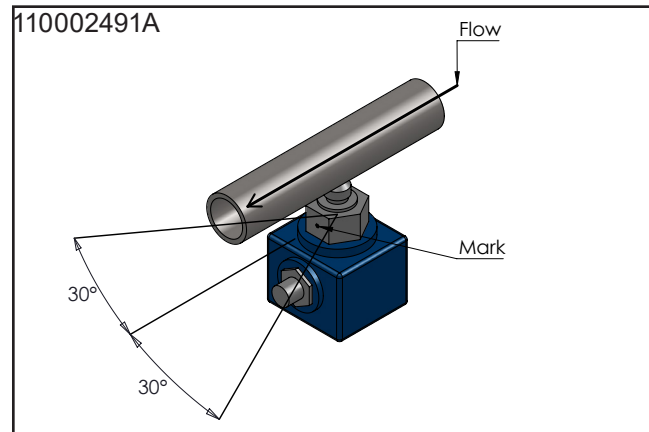

Flow switch calibration:

1. Stop the system by pressing relevant button on the control display (refer to the image below).

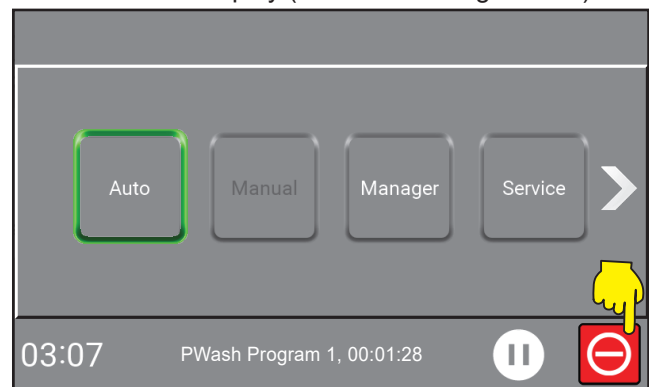

2. Remove the cover.
3. Set the "rinse/foam" handle to foam position.
4. Turn the brass screw at the bottom until two green LED light up.
5. Turn the screw counter clockwise until one of the green LEDs light up.
6. Close the water supply and verify that the red diode lights up. If not, repeat from step 4.
7. Reattach the cover.

8.3.3. Pump/motor

- No maintenance needed.
- For further information see pump suppliers instruction manual.

8.3.4. Product solenoid valve

- No maintenance needed.
- Replace defective solenoid valve and hoses with attention to flow direction marked on bracket.

1. Turn off power supply.
2. Remove screws and valves from bracket.
3. Replace valve and/or hoses, ensuring flow direction follows arrow tip pointing towards automatic block.
4. Re-attach valve to bracket.

8.4. Preventive/regular maintenance

Depending on usage, the following maintenance should take place at least once a year in order to prevent defects and operational failures.

8.4.1. Rinsing the product supply/injector system

Clean product supply after use to prevent clogging from product/disinfectant remains.

1. Remove User Pack, if necessary.
2. Hold rinsing bottle with clean water against suction opening (with User Pack) or hose (with can holders).
- Or, place User Pack with clean water in holder or hose in bucket of clean water.
3. Activate hose handle until clean water flows from nozzle (approx. 20 seconds).

Note:

Repeat procedure on all product supply systems.

8.4.2. Change of injector

Refer to image below for injector location.

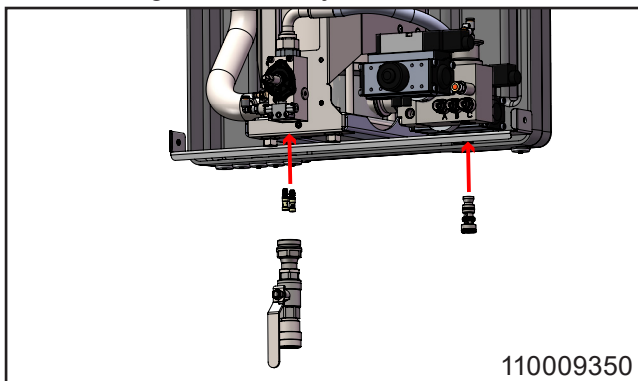

1. Turn off power supply.
2. Turn off water and air supply.
3. Depressurise the system.
4. Unscrew and change injector. Beware of chemical residue.
5. Reconnect water, air supply and power supply.

8.4.3. Deliming

The interval of the deliming procedure depends on the water hardness. Refer to table below.

°dH	ppm	Time between delimiting
0-5	18-90	12 months
5-10	90-180	6 to 12 months
10-15	180-270	3 to 6 months
15-20	270-360	3 to 6 months
>20	>360	1 to 3 months

Manual block delimiting

1. Disconnect water and power supply to the unit.
2. Remove the unit's cover.
3. Depressurize the system.
4. Remove the injector block, product non-return valve, air valve, and air non-return valve, including the air fittings.
5. Rinse the injector block in clean water.
6. Place the injector block and product non-return valves in a delimiting bath with the selector knob over the surface.
7. Wait for 60 minutes.
8. Rinse the injector block in clean water.
9. Reassemble the air valve, air non-return valve, and product non-return valve on the injector block, and mount the injector block in the unit.
10. Reconnect water to the unit.
11. Test the unit in foam position, making sure the vacuum is sufficient (recommended: 14.8-20.7 inHg/-0.05-0.07MPa).
12. Test the unit's start and stop function in both foam and rinse positions.
13. Reattach the unit's cover.

Automatic block delimiting

1. Remove the unit's cover.
2. Place the chemical supply hoses in clean water and activate the foaming function on all chemical valves for 1 minute.
1. Place the chemical hoses in delimiting fluid and activate the foaming function for all chemical valves for 1 minute.
1. Wait for 60 minutes.
2. Place the chemical hoses in clean water and activate the foaming function on all chemical valves for 5 minutes.
3. Activate the rinsing function for 1 minute.
4. Test the foaming function, making sure the vacuum is sufficient (recommended: 14.8-20.7 inHg/-0.05- 0.07MPa).
5. Reattach the unit's cover.

8.4.4. Coupling

- Lubricate all coupling parts regularly (once a month) with waterproof grease to prevent leaks and o-ring damage.
- If the unit has a spray gun, lubricate the gun's o-ring.
- Replace o-rings in leaking quick couplings.

8.4.5. Internal cleaning of the unit

- Internal cleaning of the unit is recommended once a year, depending on the environment where it is installed.
- Avoid spraying inside the unit.
- It is recommended to regularly check all product hoses approximately once every three months.

8.5. Trouble shooting and remedy

If errors or problems occur that are not described, contact the local service technician for assistance.

Fault	Cause	Remedy
The unit does not start	<ul style="list-style-type: none"> • No supply voltage to the unit • Error message in display • Flow switch out of adjustment 	<ul style="list-style-type: none"> • Reconnect voltage and ensure 3x400-480V • Read error and act accordingly • Try to readjust flow switch
No pressure / too low pressure	<ul style="list-style-type: none"> • Insufficient water supply at unit • Filter is clogged • The pump is leaking or making jarring sounds • Rinsing nozzle not installed • Defect in booster unit for satellite • No water supply 	<ul style="list-style-type: none"> • Open water supply valve • Clean the filter • Call technician • Place rinsing nozzle • Consult direction for use for booster unit • Ensure water supply
Insufficient foam creation	<ul style="list-style-type: none"> • Product not suitable • Insufficient air supply at unit • Air pressure in mixing chamber too high • Defect non-return valve for air • Incorrect nozzle • Leaking or blocked product non-return valve • System needs deliming 	<ul style="list-style-type: none"> • Choose suitable product • Provide sufficient air supply • Adjust air pressure setting • Replace non-return valve for air • Place foam nozzle 50/200 • Clean or replace product non-return valve • Delime the unit according to section 8.4.3.
No foam creation	<ul style="list-style-type: none"> • Product not suitable • Air pressure in mixing chamber too high • Defect non-return valve for air • No air supply at unit • Non-return valve blocked • Nozzle of mixing chamber blocked • Leaking or blocked product non-return valve • System needs deliming 	<ul style="list-style-type: none"> • Choose suitable product • Adjust air pressure setting • Replace non-return valve for air • Ensure air supply • Clean or replace non-return valve • Clean nozzle • Clean or replace product non-return valve • Delime the unit according to section 8.4.3.
No spray sanitising	<ul style="list-style-type: none"> • Non-return valve blocked • Nozzle of mixing chamber blocked • Leaking or blocked product non-return valve • System needs deliming 	<ul style="list-style-type: none"> • Clean or replace non-return valve • Clean nozzle • Clean or replace product non-return valve • Delime the unit according to section 8.4.3.

8.6. Service address

Refer the back of this manual.

9. End of Use

9.1. Dismounting

1. Make sure the system is flushed with clean water before dismounting.
2. Turn of the power.
3. Close the water supply.
4. Close the air supply.
5. Depresurize.

9.2. Disposal

If unit needs to be disposed, separate recyclable and non-recyclable parts. Steel construction is easily separable and poses no environmental risk. Follow all relevant rules and regulations for machine disposal and protect the environment.



CAUTION

Disposal of electronic components and other remedies must be handled as special disposal when disposed. Alternatively, it can be disposed by a specialised disposal company.

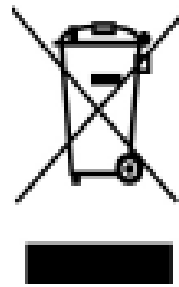

10. Spare part list
Hybrid 7 Foamatic MA/SA

10.1. MA overview

MA2iM, MA3iM, MA2i, MA3i, MA2M, MA3M, MA2, MA3

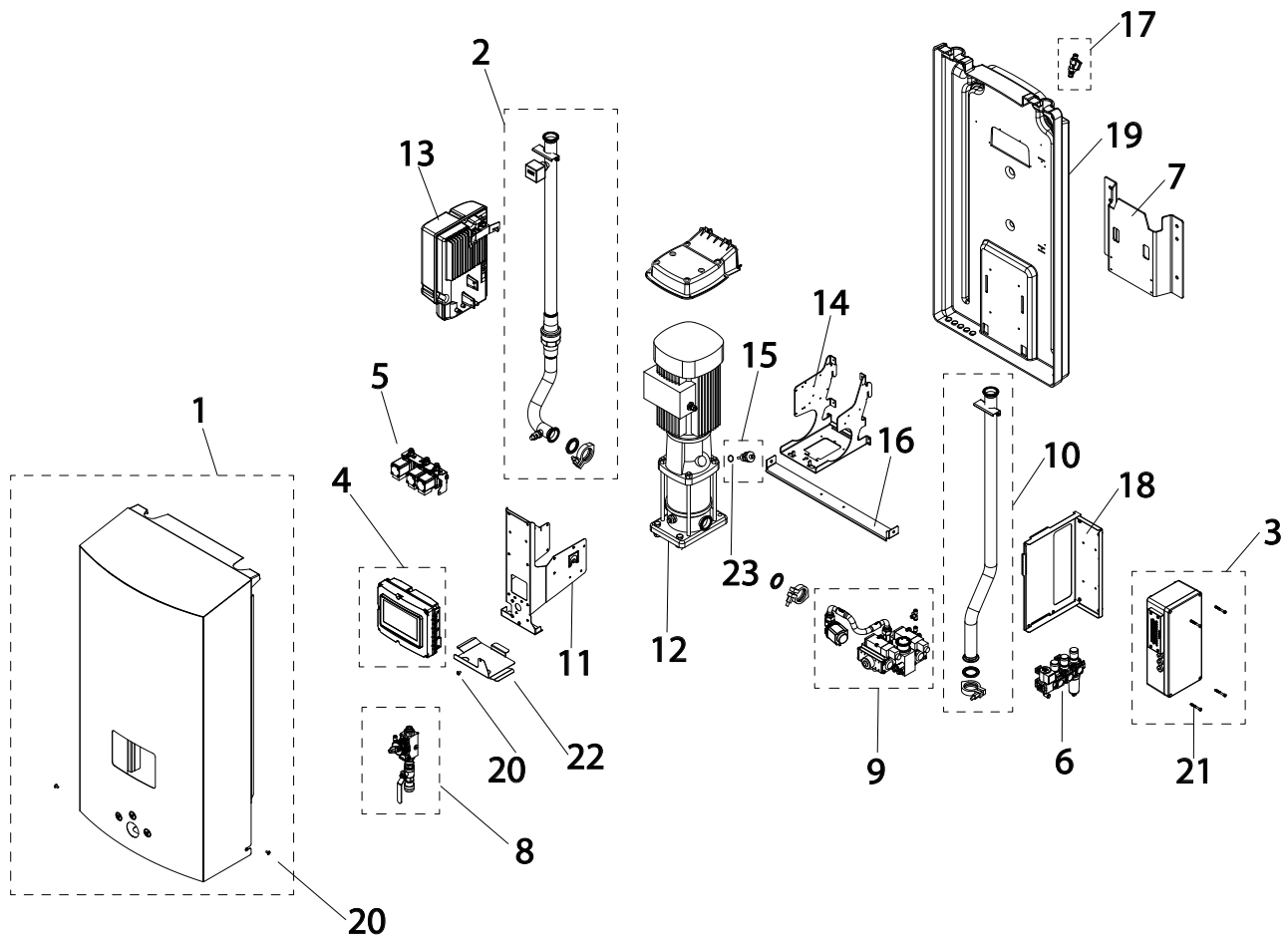

110009278A

Pos./Ref.	Nr. No.	Description Beschreibung Désignation Designación	MA2i	MA3i	MA2IM	MA3IM	MA2M	MA3M	MA2	MA3
1	110009303	Cover complete MAxx	1	1					1	1
1	110009304	Cover complete MAxxM			1	1	1	1		
2		Inlet MA complete - see page 34/35	1	1	1	1	1	1	1	1
3	110009298	IO module complete	1	1	1	1				
4		Controller with display - see page 40/41	1	1	1	1	1	1	1	1
5		Product solenoid valve - see page 38/39	1	1	1	1	1	1	1	1
6	110009300	Air regulation complete	1	1	1	1	1	1	1	1
7	110001141	Wall bracket	1	1	1	1	1	1	1	1
8		Manual block complete - see page 30/31			1	1	1	1		
9		Automatic block complete - see page 32/33	1	1	1	1	1	1	1	1
10		Outlet MA complete - see page 34/35	1	1	1	1	1	1	1	1
11	110008614	Main bracket Serial no.: →204.02.000XXX	1	1	1	1	1	1	1	1
11	110009439	Main bracket Serial no.: 204.02.000XXX→	1	1	1	1	1	1	1	1
12	110004300	Pump CRN 5-6kW	1	1	1	1	1	1	1	1
13	110008187	Inverter complete	1	1	1	1	1	1	1	1
14	0606644	Pump bracket Serial no.: →204.02.000XXX	1	1	1	1	1	1	1	1
14	110009411	Pump bracket Serial no.: 204.02.000XXX→	1	1	1	1	1	1	1	1
15	110004713	PT1000 sensor complete	1	1	1	1	1	1	1	1
16	110003496	Cover bracket	1	1	1	1	1	1	1	1
17	110009299	Air valve complete	1	1	1	1	1	1	1	1
18	110008798	I/O bracket	1	1	1	1	1	1	1	1
19	0606745	Back cabinet	1	1	1	1	1	1	1	1
20	110003512 (110007782)	Screw kit								
21	110003512 (320000)	Screw kit								
22	110009268	Hose guard bracket MA	1	1	1	1	1	1	1	1
23	110005355 (110008447)	O-ring kit								

10.2. SA overview

SA2iM, SA3iM, SA2i, SA3i

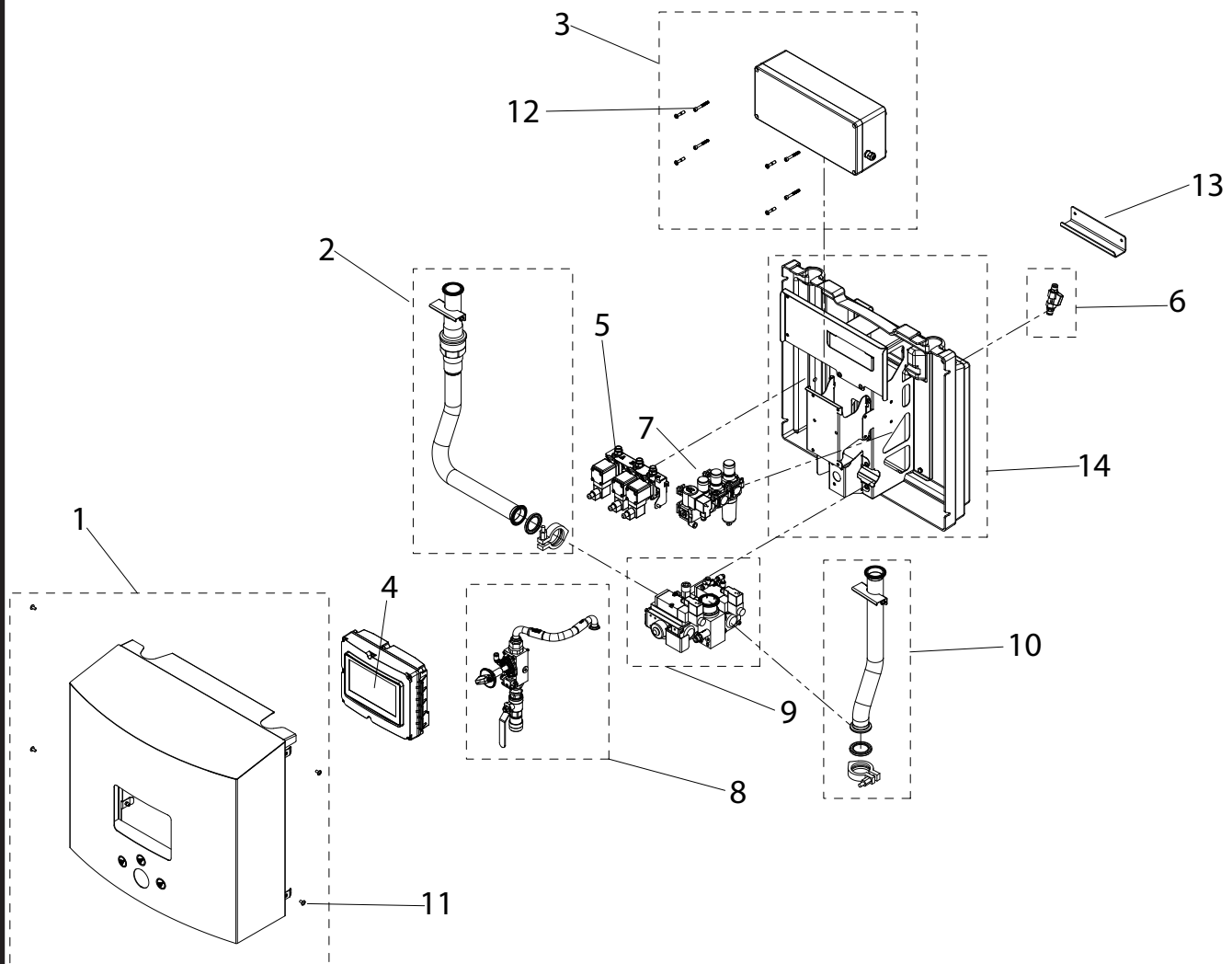

110009210A-003

Pos./Ref.	Nr. No.	Description Beschreibung Désignation Designación	SA2i	SA3i	SA2iM	SA3iM
1	110009296	Cover complete SAxxM			1	1
1	110009297	Cover complete SAxx	1	1		
2		Inlet complete SA - See page 36/37	1	1	1	1
3	110009298	I/O module complete	1	1	1	1
4		Controller with display - See page 40/41	1	1	1	1
5		Product solenoid valve - See page 38/39	1	1	1	1
6	110009299	Stop valve air, complete	1	1	1	1
7	110009300	Air regulation complete	1	1	1	1
8		Manual block complete - See page 30/31			1	1
9		Automatic block complete - See page 32/33	1	1	1	1
10		Outlet complete SA - See page 36/37	1	1	1	1
11	110003512 (110007782)	Screw kit				
12	110003512 (320000)	Screw kit				
13	110005204	Wall bracket	1	1	1	1
14	110009307	SA brackets complete	1	1	1	1

10.3. Manual block

MA2iM, MA3iM, MA2M, MA3M, SA2iM, SA3iM,

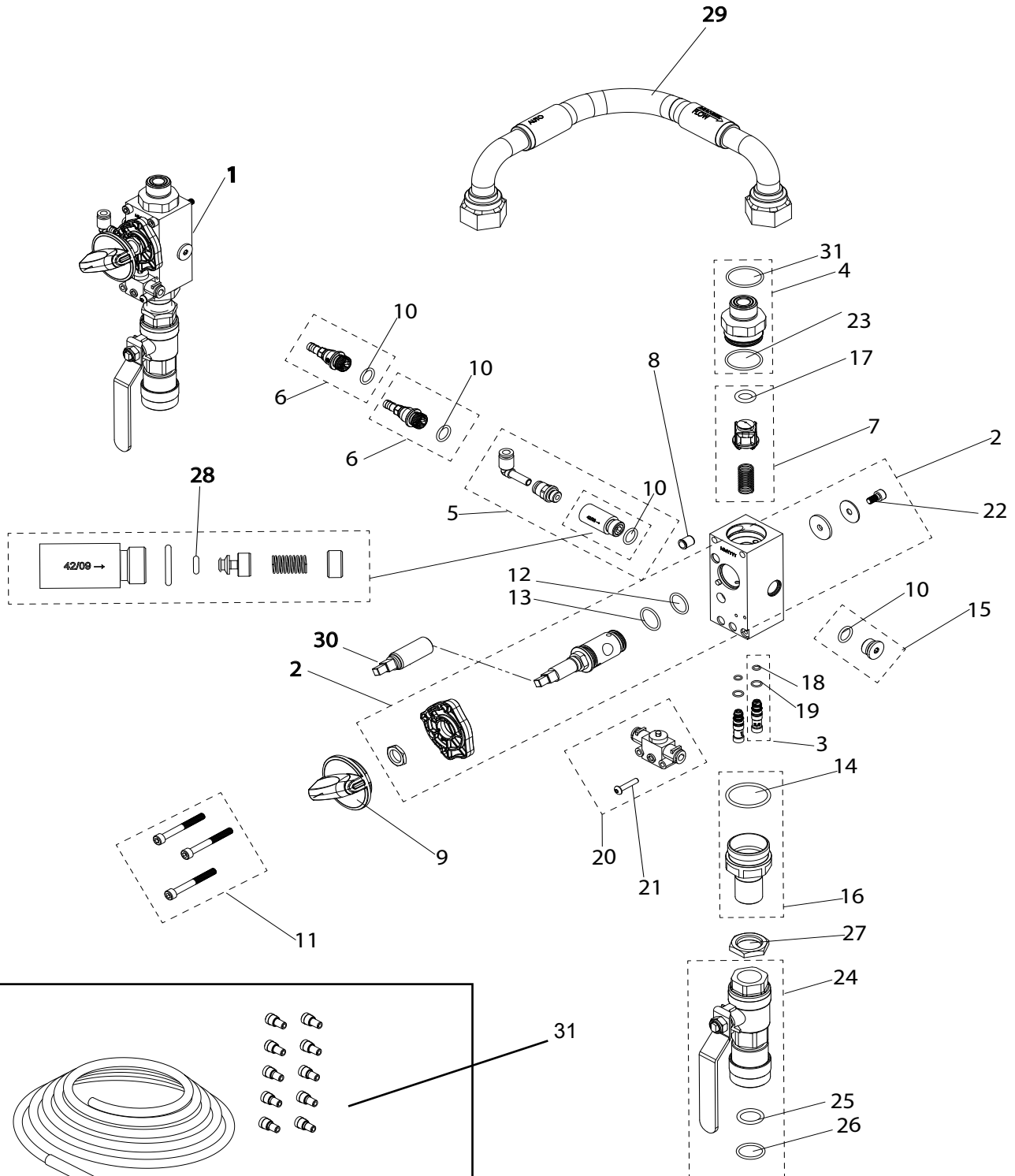

Image: 110001405V2

110009212

Pos./Ref.	Nr. No.	Description Beschreibung Désignation Designación	MA2IM	MA3IM	MA2M	MA3M	SA2IM	SA3IM
1	110008806	Block complete	1	1	1	1	1	1
2	110007101	Axle complete	1	1	1	1	1	1
3	110007098	Injector kit	2	2	2	2	2	2
4	110009405	Inlet connection kit	1	1	1	1	1	1
5	110007136	Air non return valve with fitting	1	1	1	1	1	1
6	110004434	Product non return valve	2	2	1	1	2	2
7	110008772	Water non return valve	1	1	1	1	1	1
8	110002392	Flexible pressure piece	1	1	1	1	1	1
9	909100249	Selector knob	1	1	1	1	1	1
10	110005355 (110002952)	O-ring kit						
11	110003512 (110000526)	Screw kit						
12	110005355 (110002508)	O-ring kit						
13	110005355 (350108)	O-ring kit						
14	110005355 (0635040)	O-ring kit						
15	110002306	Plug	1	1	1	1	1	1
16	110006214	Outlet	1	1	1	1	1	1
17	110005355 (110008303)	O-ring kit						
18	110005355 (110004888)	O-ring kit						
19	110005355 (110004887)	O-ring kit						
20	110008923	Air valve complete	1	1	1	1	1	1
21	110003512 (110003408)	Screw kit						
22	110003512 (110003408)	Screw kit						
23	110005355 (0635040)	O-ring kit						
24	110005460	Outlet	1	1	1	1	1	1
25	110005355 (641101)	O-ring kit						
26	110005355 (641101)	O-ring kit						
27	350705	Nut	1	1	1	1	1	1
28	110005355 (0635021)	O-ring kit						
29	110009260	Hose MA	1	1	1	1		
29	110009316	Hose SA					1	1
30	110009301	Axle extension SA					1	1
31	110005355 (0600016)	O-ring kit						
32	110008868 110008869 110008870 110008871 0614213	Product hose (blue) Product hose (yellow) Product hose (red) Product hose (green) Product limiting nozzle						

10.4. Automatic block

**MA2iM, MA3iM, MA2i, MA3i, MA2M, MA3M, MA2, MA3
SAiM, SA3iM, SA2i, SA3i**

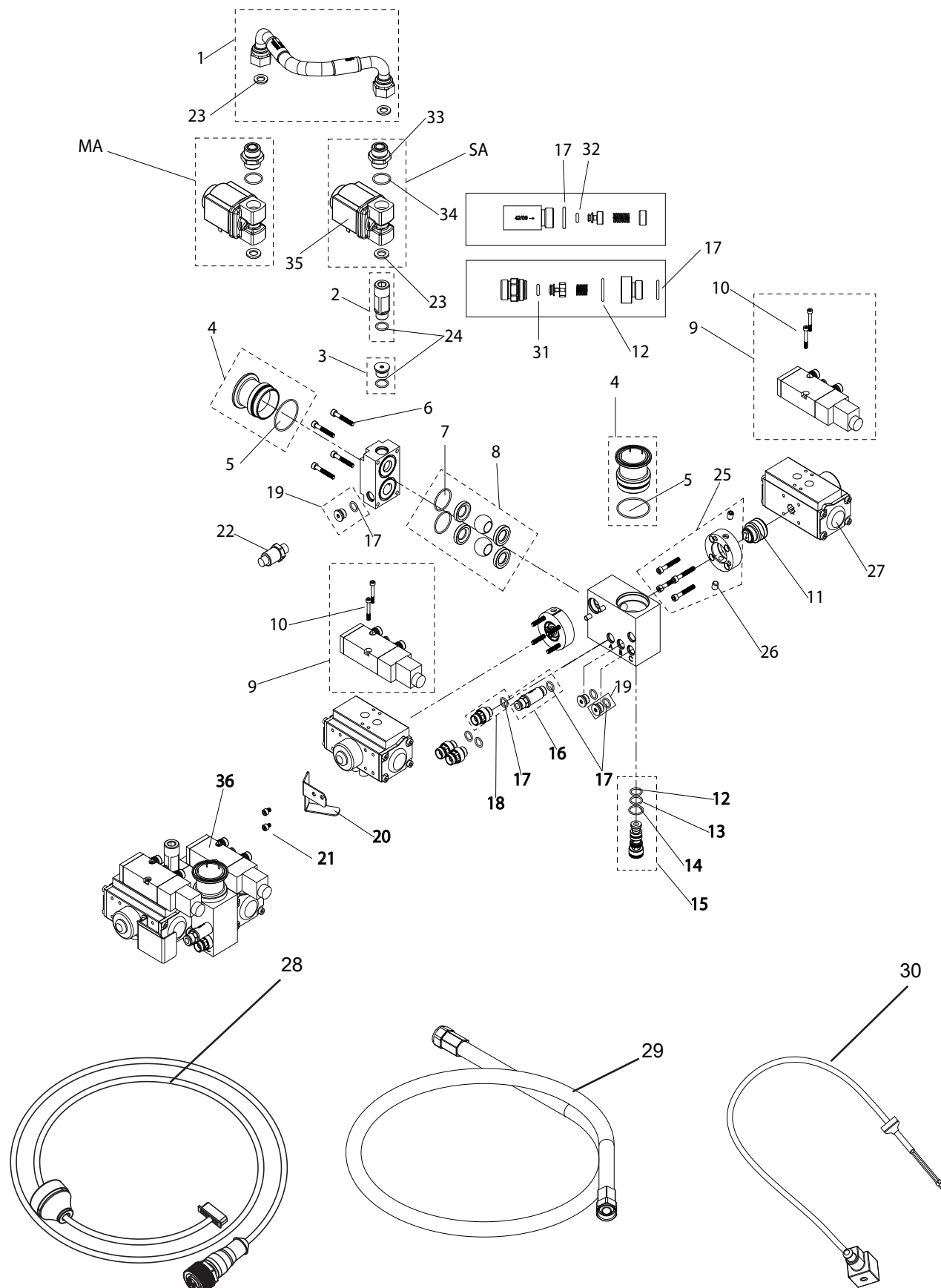

Image: 110006921

Image: 110009135

Image: 110001934A-002

Pos./Ref.	Nr. No.	Description Beschreibung Désignation Designación	MA2IM	MA3IM	MA2i	MA3i	MA2M	MA3M	MA2	MA3	SA2IM	SA3IM	SA2i	SA3i
1	110009260	Hose MA	1	1	1	1	1	1	1	1				
1	110009316	Hose SA									1	1	1	1
2	110005274	Fitting 3/8" - 1/2"	1	1			1	1			1	1		
3	110005275	Plug 3/8"			1	1			1	1			1	1
4	110005279	Clamp fitting	2	2	2	2	2	2	2	2	2	2	2	2
5	110005355 (110004837)	O-ring kit												
6	110003512 (110005104)	Screw kit												
7	110005355 (110004835)	O-ring kit												
8	110005276	Service kit actuator	1	1	1	1	1	1	1	1	1	1	1	1
9	110004622	Solenoid air valve	2	2	2	2	2	2	2	2	2	2	2	2
10	110003512 (110004573)	Screw kit												
11	110005277	Service kit automatic block												
12	110005355 (110004870)	O-ring kit												
13	110005355 (110004871)	O-ring kit												
14	110005355 (110002955)	O-ring kit												
15	110005362	Injector kit 150												
15	110005278	Injector kit 300												
15	110005363	Injector kit 450												
16	110001979	Air non return valve												
17	110005355 (110002952)	O-ring kit												
18	110008706	Product non return valve	2	3	2	3	2	3	2	3	2	3	2	3
19	110002306	Plug	1		1		1		1		1		1	
20	110009209	Hose bracket SA									1	1	1	1
21	110003512 (110003900)	Screw kit												
22	110000890	Sensor												
23	110005355 (0635042)	O-ring kit												
24	110005355 (110004140)	O-ring kit												
25	110005351	Fixation for actuator												
26	110003512 (156519)	Pinol screw												
27	0605792	Actuator												
28	110006921	Sensor cable												
29	110009134	Product hose	2	3	2	3	2	3	2	3	2	3	2	3
30	110001932	Solenoid air valve cable	2	2	2	2	2	2	2	2	2	2	2	2
31	110005355 (110009229)	O-ring kit												
32	110005355 (0635021)	O-ring kit												
33	110009338	Solenoid fitting												
34	110005355 (0600016)	O-ring kit												
35	110008563	Water solenoid valve												
36	110009145	Automatic block complete 3M		1			1					1		
36	110009144	Automatic block complete 2M	1				1				1			
36	110009147	Automatic block complete 3				1				1				1
36	110009146	Automatic block complete 2			1				1				1	

10.5. Inlet & outlet pipe MA

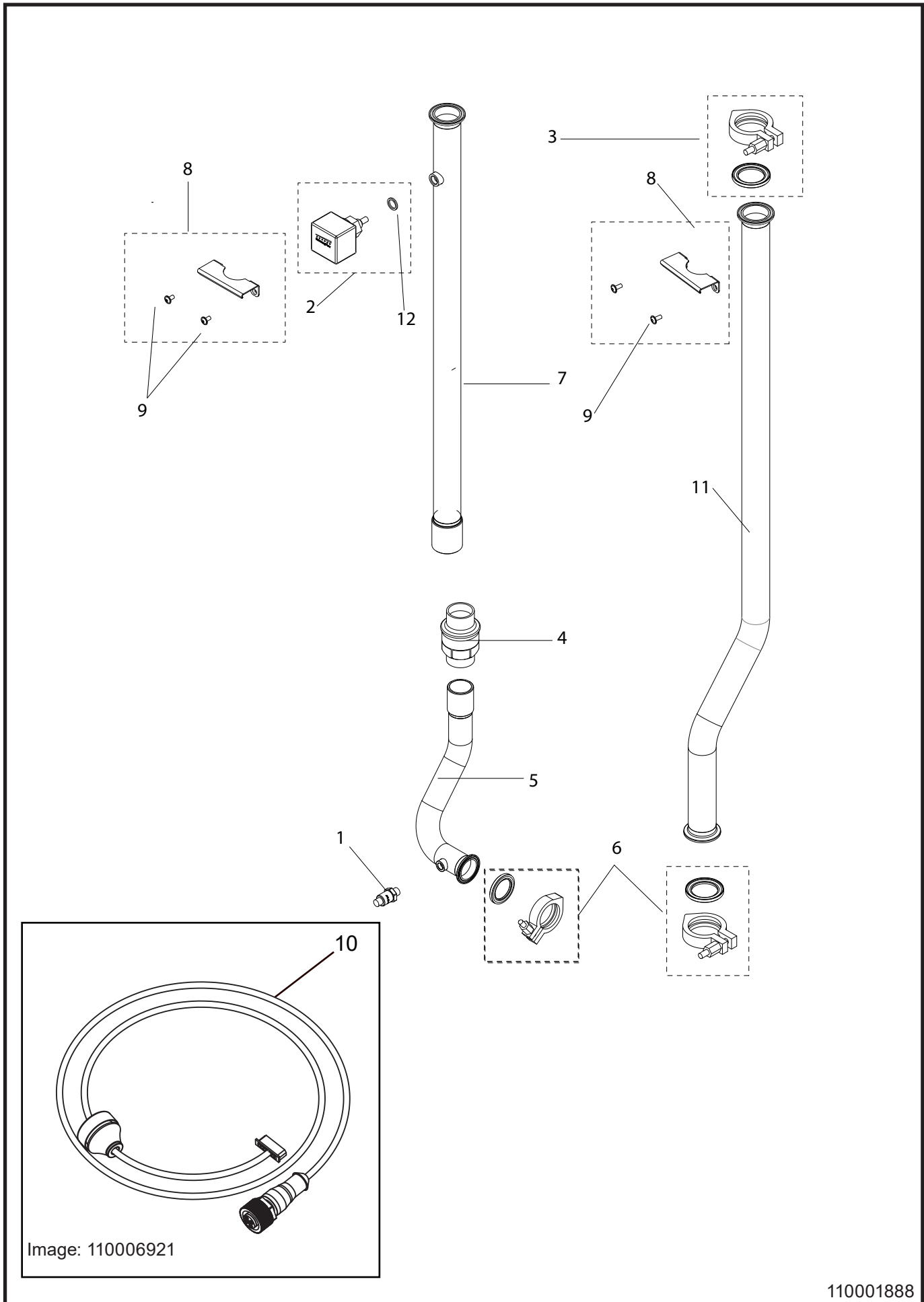

110001888

Pos./Ref.	Nr. No.	Description Beschreibung Désignation Designación	MA2I	MA3I	MA2IM	MA3IM	MA2M	MA3M	MA2	MA3
1	11000889	Sensor -1-16 bar	1	1	1	1	1	1	1	1
2	11000963	Flow switch	1	1	1	1	1	1	1	1
3	110005273	Clamp kit	1	1	1	1	1	1	1	1
4	630900	Non return valve 1 1/4"	1	1	1	1	1	1	1	1
5	110004913	Piping support inlet	1	1	1	1	1	1	1	1
6	110005273	Clamp kit	1	1	1	1	1	1	1	1
7	110005200	Inlet pipe straight	1	1	1	1	1	1	1	1
8	110005280	Bracket kit	1	1	1	1	1	1	1	1
9	110003512 (110005317)	Screw kit								
10	110006921	Sensor cable	1	1	1	1	1	1	1	1
11	110005106	Outlet MA	1	1	1	1	1	1	1	1
12	110005355 (638100)	O-ring kit								

10.6. Inlet & outlet pipe SA

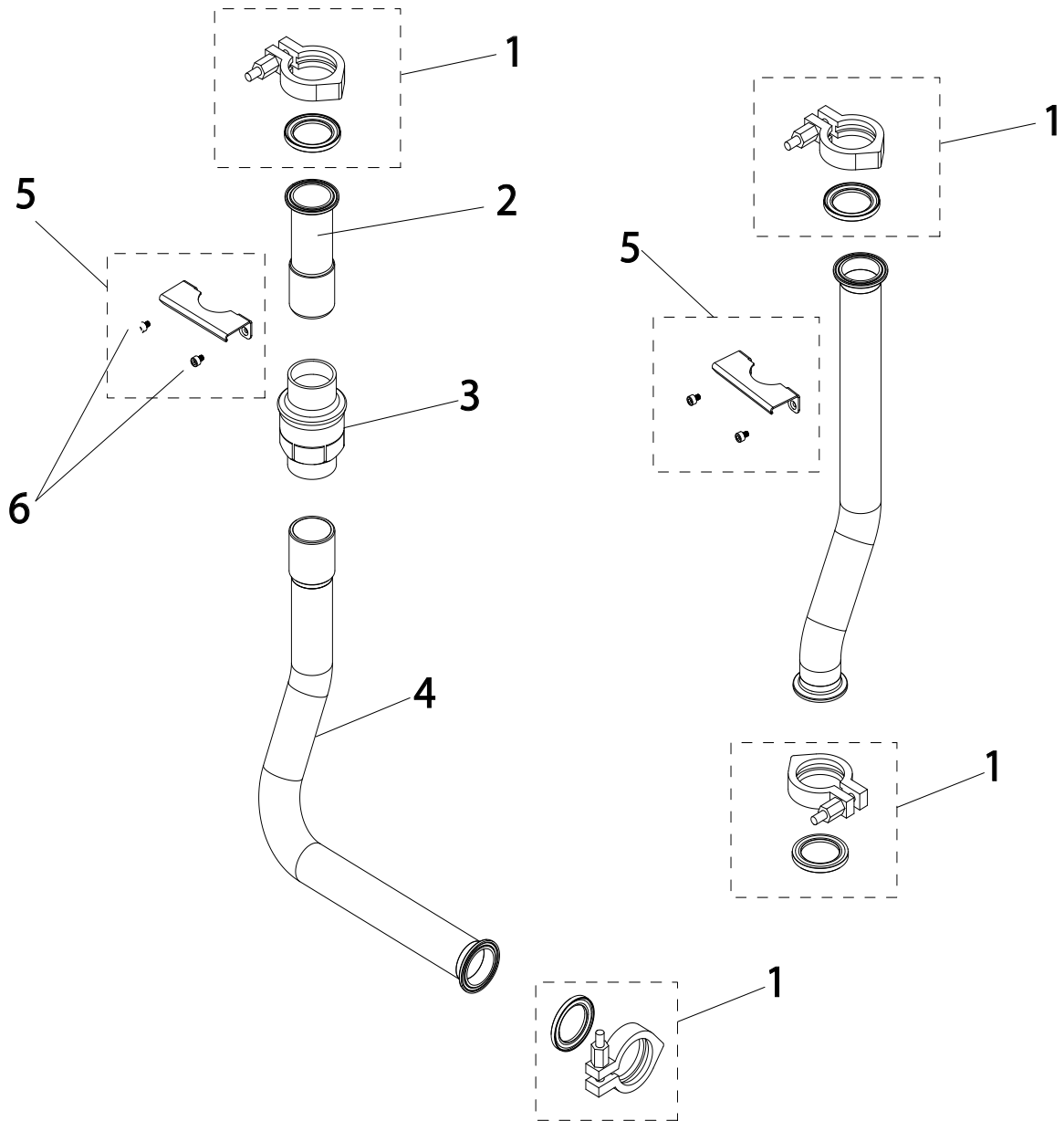

110009223

Pos./Ref.	Nr. No.	Description Beschreibung Désignation Designación	SA2I	SA3I	SA2IM	SA3IM
1	110005273	Clamp kit	4	4	4	4
2	110005257	Inlet pipe	1	1	1	1
3	630900	Water non return valve	1	1	1	1
4	110005198	Bended inlet pipe	1	1	1	1
5	110005280	Bracket kit	2	2	2	2
6	110003512 (110003900)	Screw kit				

10.7. Product solenoid valve

MA2iM, MA3iM, MA2i, MA3i, MA2M, MA3M, MA2, MA3
SA2iM, SA3iM, SA2i, SA3i,

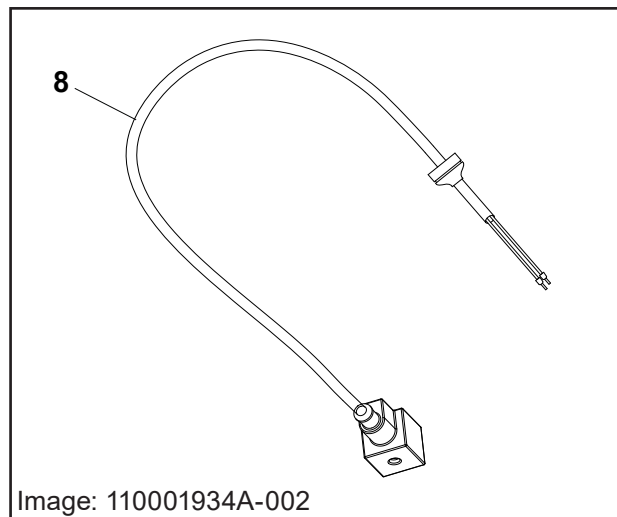
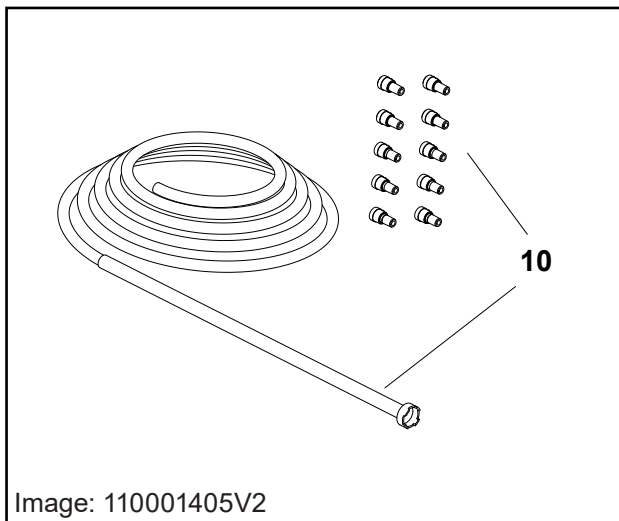
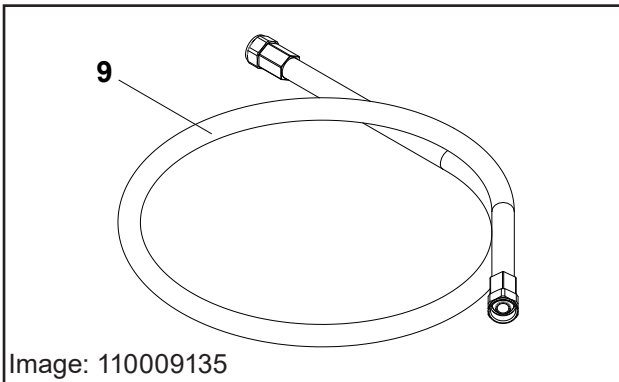
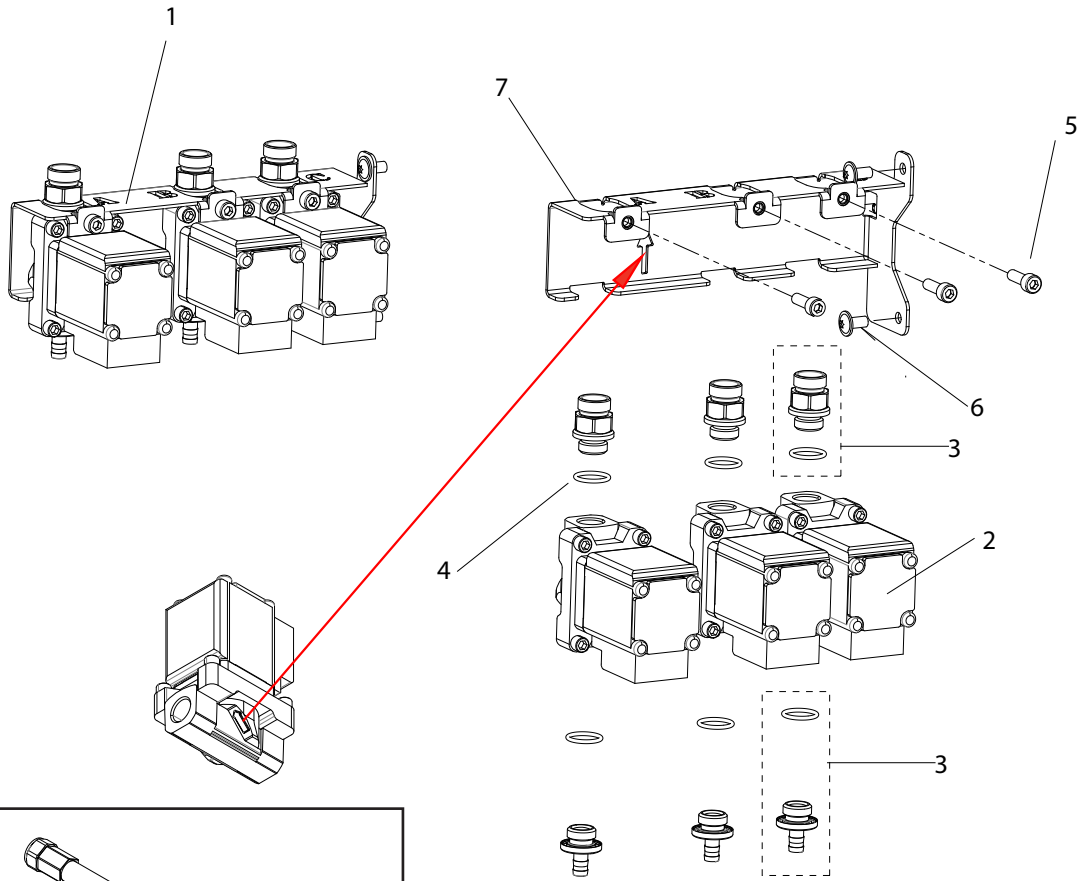

110009213-002

Pos./Ref.	Nr. No.	Description Beschreibung Désignation Designación	MA2IM	MA3IM	MA2i	MA3i	MA2M	MA3M	MA2	MA3	SA2IM	SA3IM	SA2i	SA3i
1	110009232	2 product solenoid valve complete	1		1		1		1		1		1	
1	110009168	3 product solenoid valve complete			1				1		1		1	
2	110006599	Solenoid valve EPDM	2	3	2	3	2	3	2	3	2	3	2	3
2	110009805	Solenoid valve (Option) Viton												
3	110009284	Fitting kit												
4	110005355 (110004870)	O-ring kit												
5	110003512 (156313)	Screw kit												
6	110003512 (110007782)	Screw kit												
7	110009179	Bracket	1	1	1	1	1	1	1	1	1	1	1	1
8	110001934	Product solenoid valve cable	2	3	2	3	2	3	2	3	2	3	2	3
9	110009134	Product connection hose	2	3	2	3	2	3	2	3	2	3	2	3
10	110008868 110008869 110008870 110008871 0614213	Product hose (blue) Product hose (yellow) Product hose (red) Product hose (green) Product limiting nozzle												

10.8. Controller with display

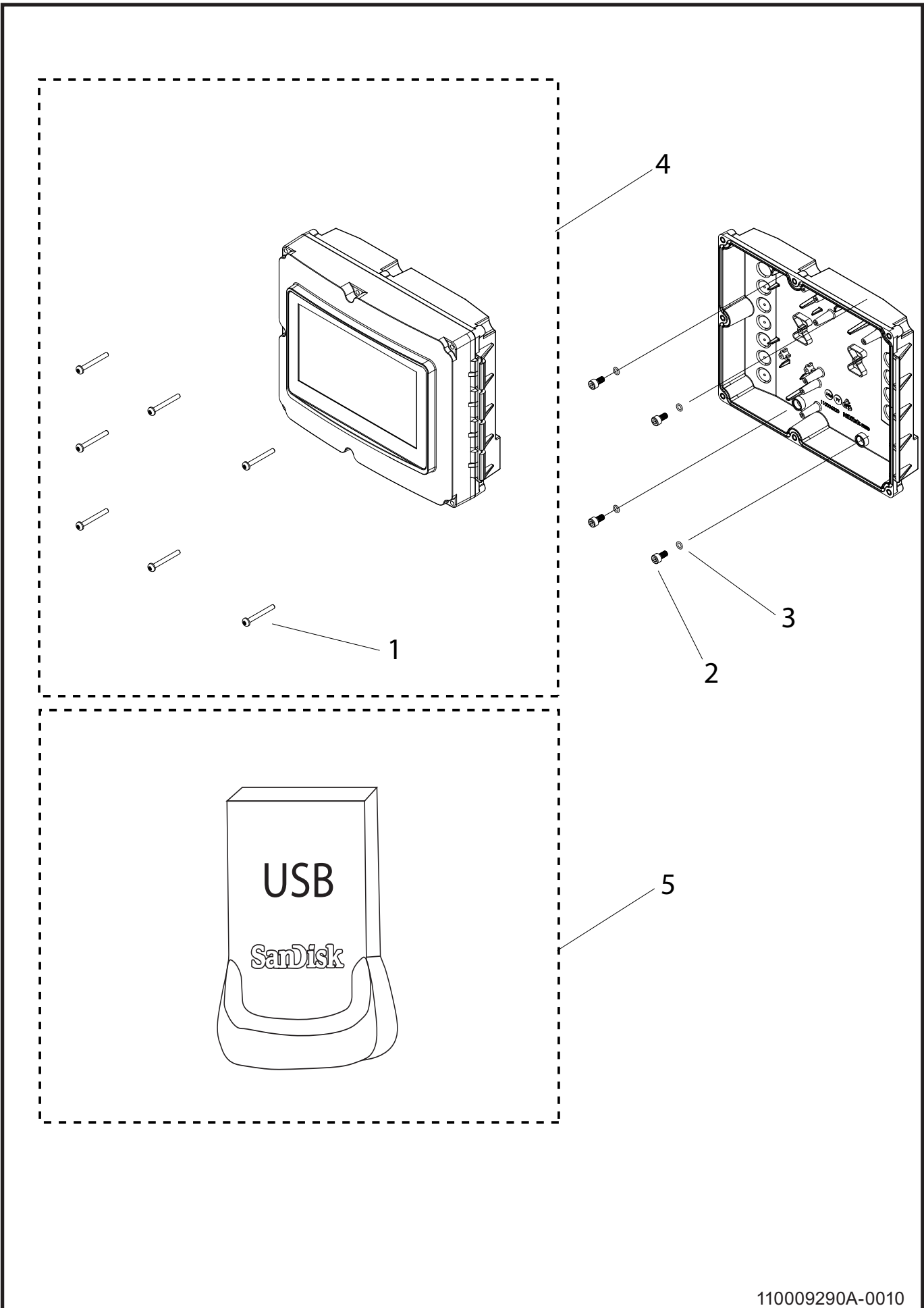

110009290A-0010

Pos./Ref.	Nr. No.	Description Beschreibung Désignation Designación	MA2IM	MA3IM	MA2i	MA3i	MA2M	MA3M	MA2	MA3	SA2IM	SA3IM	SA2i	SA3i
1	110003512 (110006876)	Screw kit												
2	110003512 (0600009)	Screw kit												
3	110005355 (0635037)	O-ring kit												
4	110009331	Controller with display complete	1	1	1	1					1	1	1	1
4	110009440	Controller with display complete					1	1	1	1				
5	110009400	Software Flash drive												

11. Sensors & diagrams MA

11.1. Operating Diagram MA

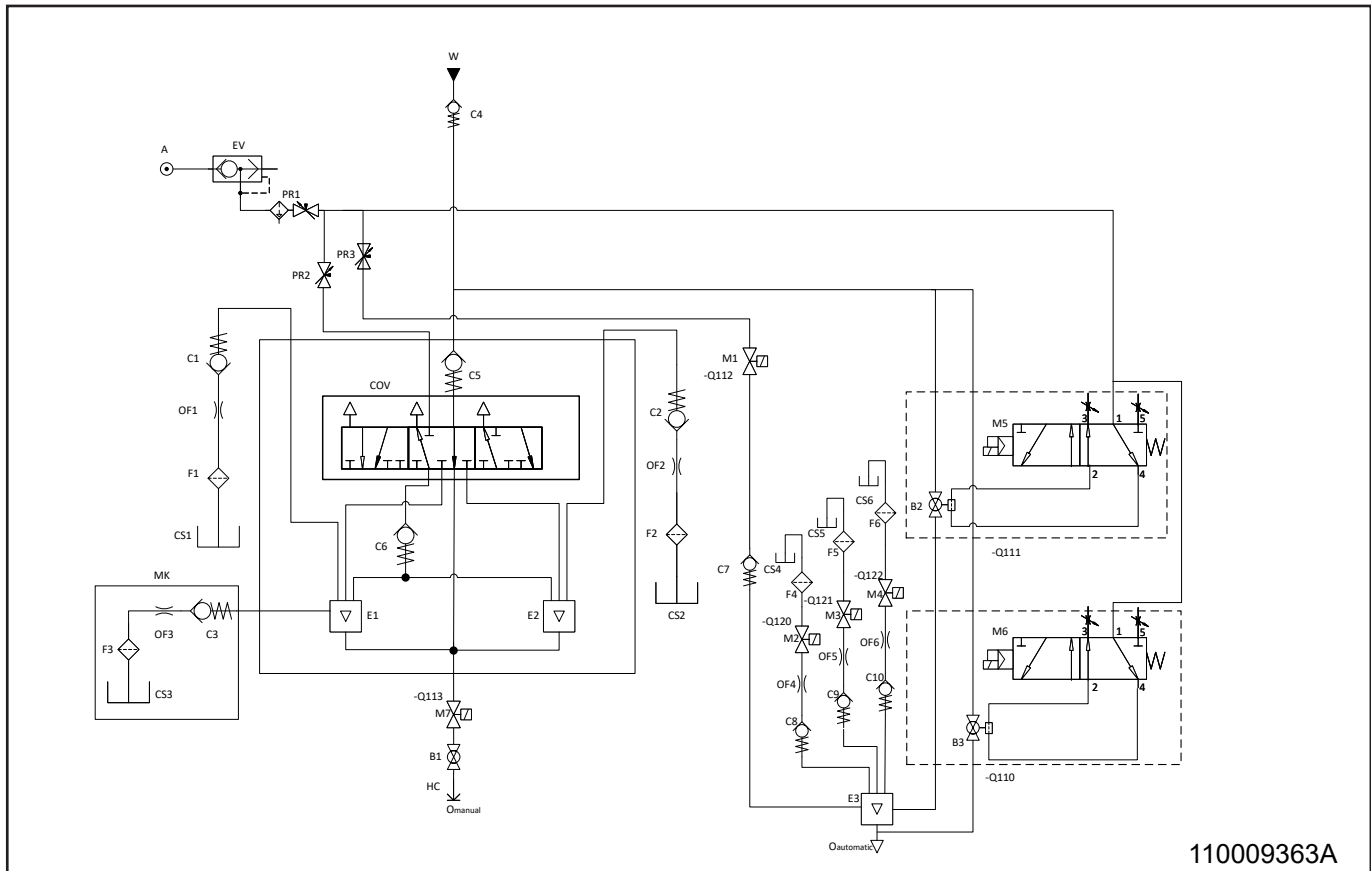

	English	Deutsch	Français	Español	Italian
A	Air supply	Lufteingang	Alimentation air	Suministro de aire	Alimentazione dell'aria
B	Ball valve	Kugelventil	Clapet à bille	Válvula esférica	Valvola a sfera
C	Check valve	Rückschlagventil	Soupape de non retour	Válvula de retención	Valvola di ritegno
COV	Change over valve	Umschaltventil	Robinet coupleur	Válvula de conmutación	Valvola di commutazione
CP	Centrifugal pump	Kreiselpumpe	Pompe Centrifuge	Bomba centrífuga	Pompa centrifuga
CS	Product supply	Chemische Versorgung	Fourniture de produits chimiques	Toma de suministro de productos quimicos	Fornitura di prodotti
E	Ejector	Ausstoß	Ejecteur	Eyector	Espulsore
EV	Exhaust valve	Ejektor	Ejecteur	Eyector	Valvola di scarico
F	Filter	Filter	Filtre	Filtro	Filtro
FST	Flow sensor and -trigger	Durchflusssensor und auslöser	Capteur de débit et de déclenchement	Sensor de caudal y de activación	Sensore di flusso e grilletto
HC	Hose coupling	Schlangenverbindung	Connexion flexible	Conexión de tubo flexible	Attacco tubo flessibile
K	Component reference	Komponentenreferenz	Référence composant	Referencia del componente	Riferimento componente
M	Magnetic valve	Magnetventil	Vanne magnétique	Válvula magnética	Valvola magnetica
MK	Mix kit (Optional)	Misch-Kit (Optional)	Kit de mélange (Optionnel)	Kit de mezcla (Opcional)	Kit di mix (facoltativo)
O	Outlet	Ausgang	Sortie	Salida	Preso
OF	Orifice	Blende	Orifice	Orificio	Orifizio
PE	Pressure sensor	Drucksensor	Capteur de pression	Sensor de presión	Sensore di pressione
PR	Pressure regulator	Druckregler	Régulateur de pression	Régulador de presión	Regolatore di pressione
TE	Temperature sensor	Temperatursensor	Capteur de température	Sensor de temperatura	Termometro
W	Water inlet	Wasserzufluss	Arrivée d'eau	Entrada de agua	Ingresso acqua

11.2. Electrical ratings MA

IO module		
Output ratings		
Max. load single output	A	0.8
Max load sum of all outputs	A	3.2
Voltage nom.	V	24
Voltage min.	V	22
Voltage max.	V	24.5
Input ratings		
Input voltage nom.	V	24
Min. input voltage on	V	22
Max. input voltage on	V	25
Max. input voltage off	V	2

11.3. Component location MA

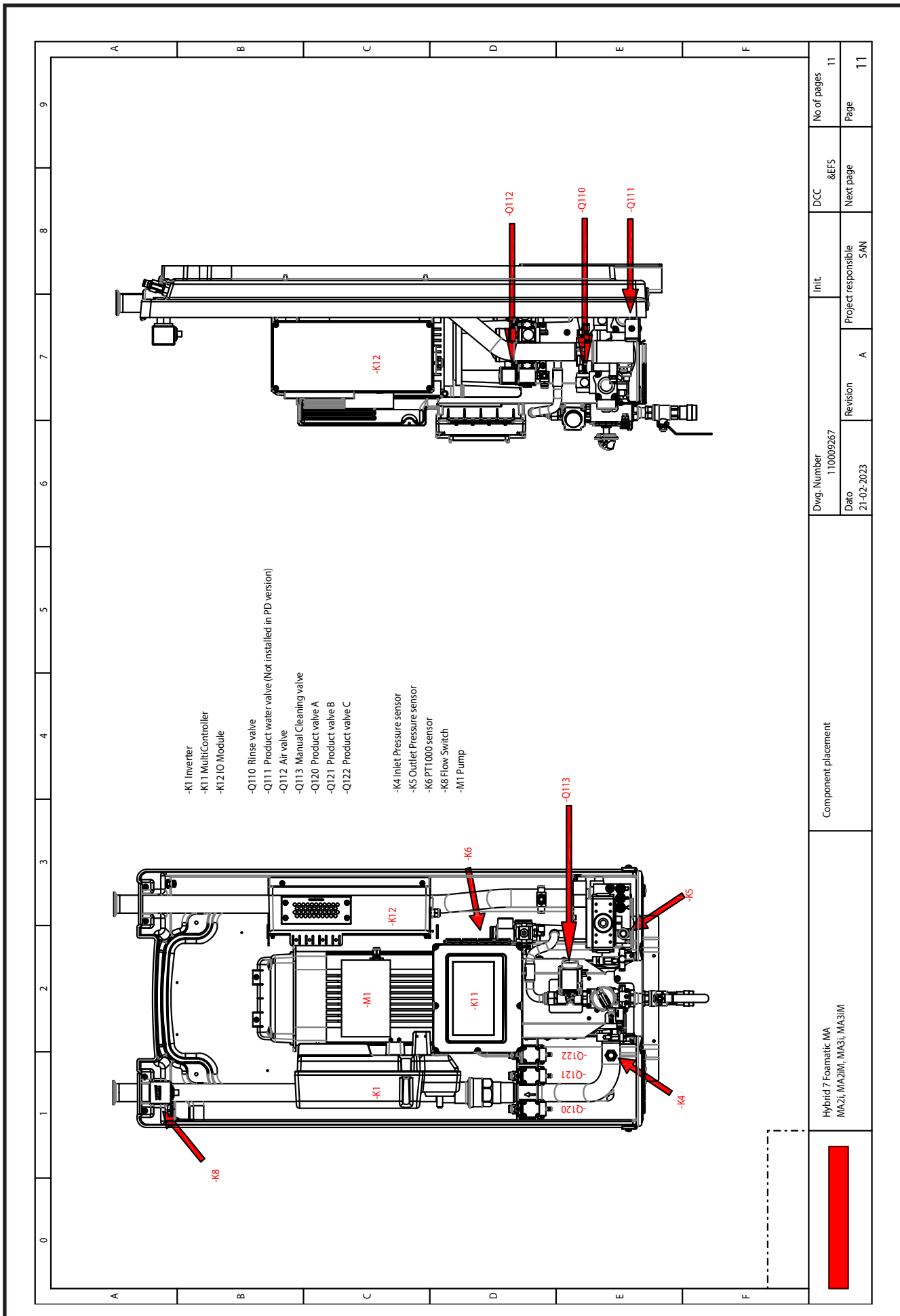

Hybrid 7 Foomatic MA MA2i, MA2iM, MA3i, MA3iM	Component placement		Dwg. Number 110009267	Init.	DCC	No of pages 11
	Revision A		Date 21-02-2023	Project responsible SAN	Next page	Page 11

11.4. Circuit diagrams & sensor diagrams MA2IM, MA3IM, MA2I, MA3I

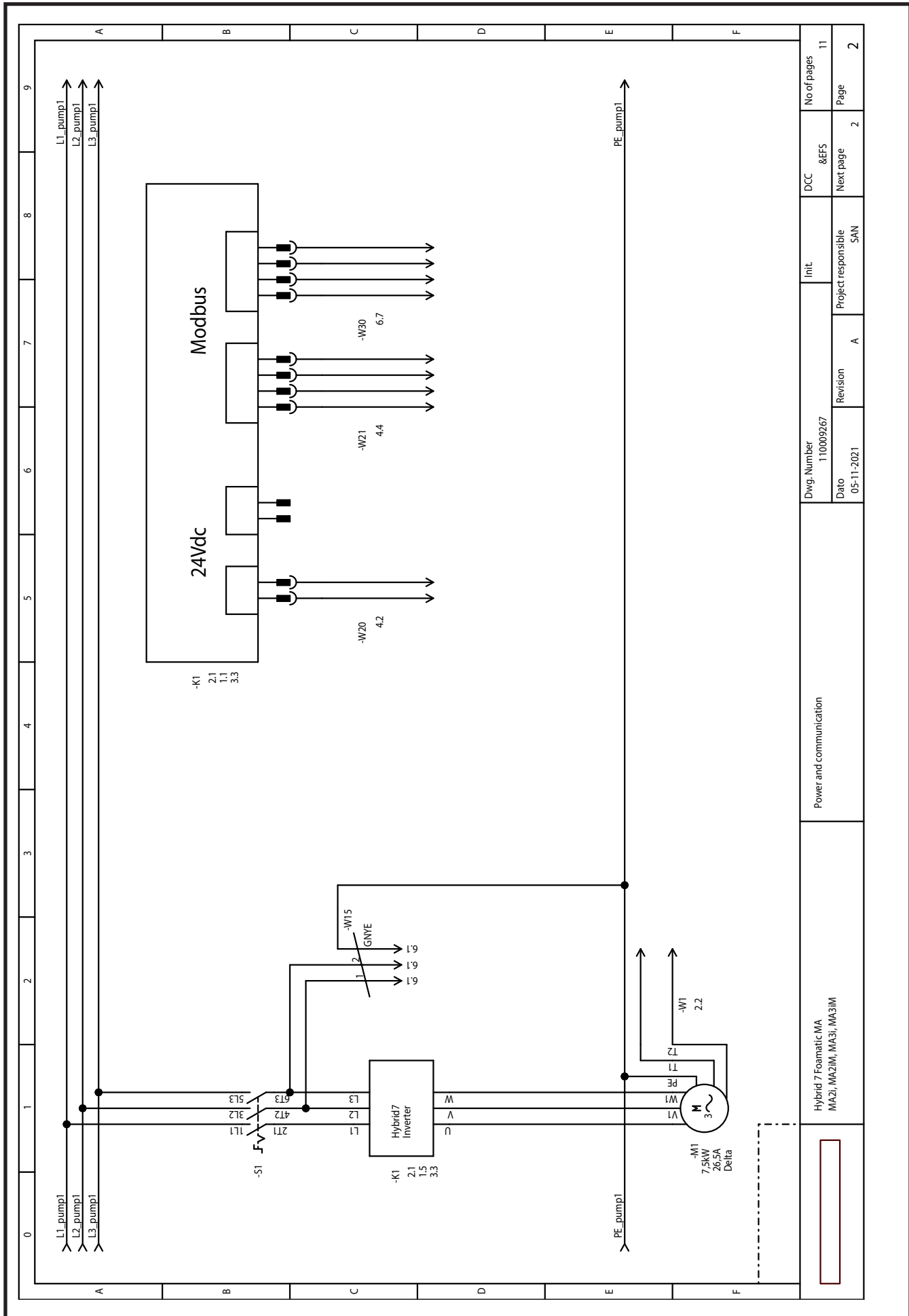

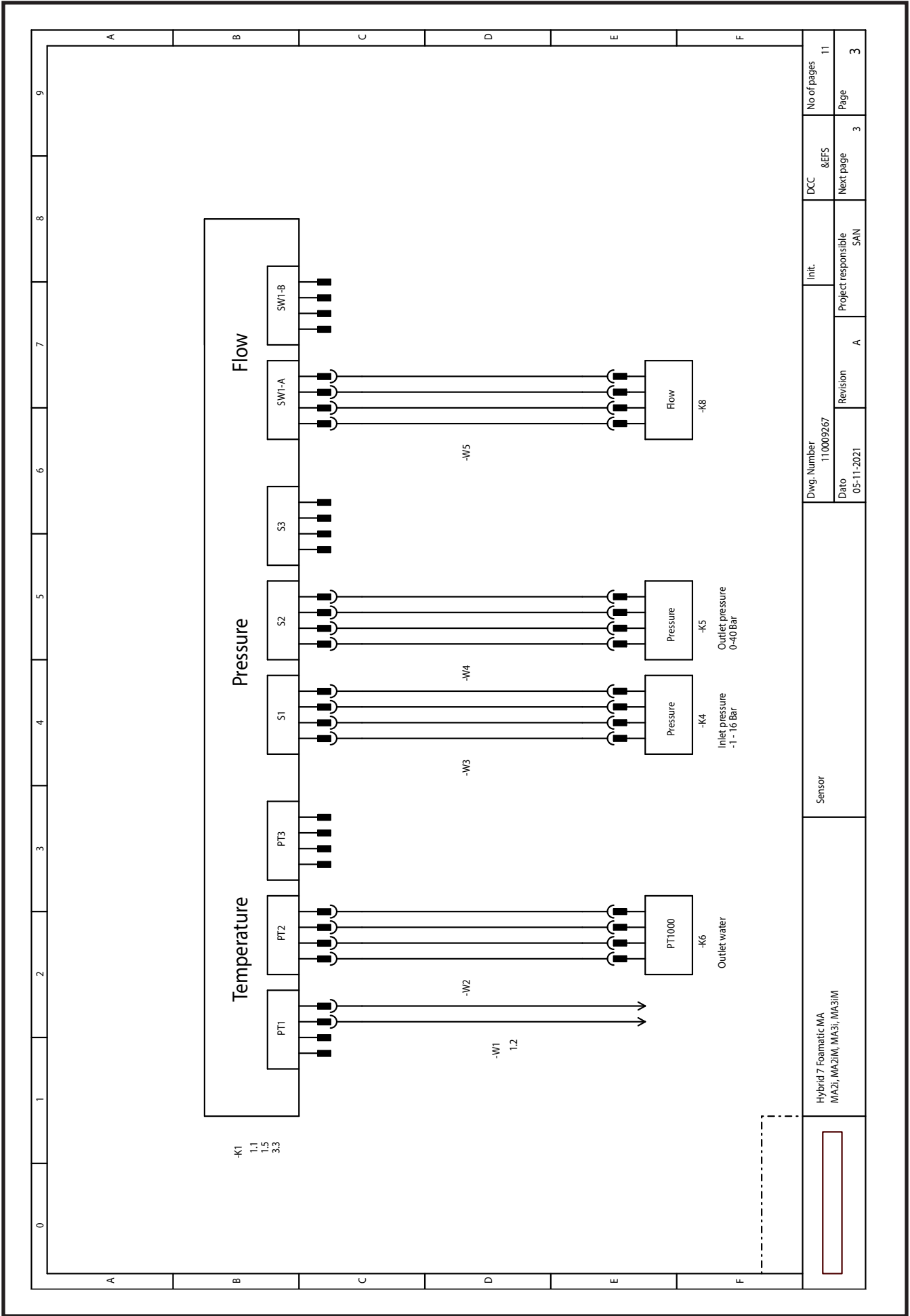

<div style="border: 1px solid black; width: 100px; height: 20px; margin-bottom: 5px;"></div> Hybrid 7 Foamatic MA MA2i, MA2iM, MA3i, MA3iM	Sensor		Dwg. Number 110009267		DCC &EFS	No. of pages 11
			Revision A	Init. Project responsible SAN	Next page 3	Page 3

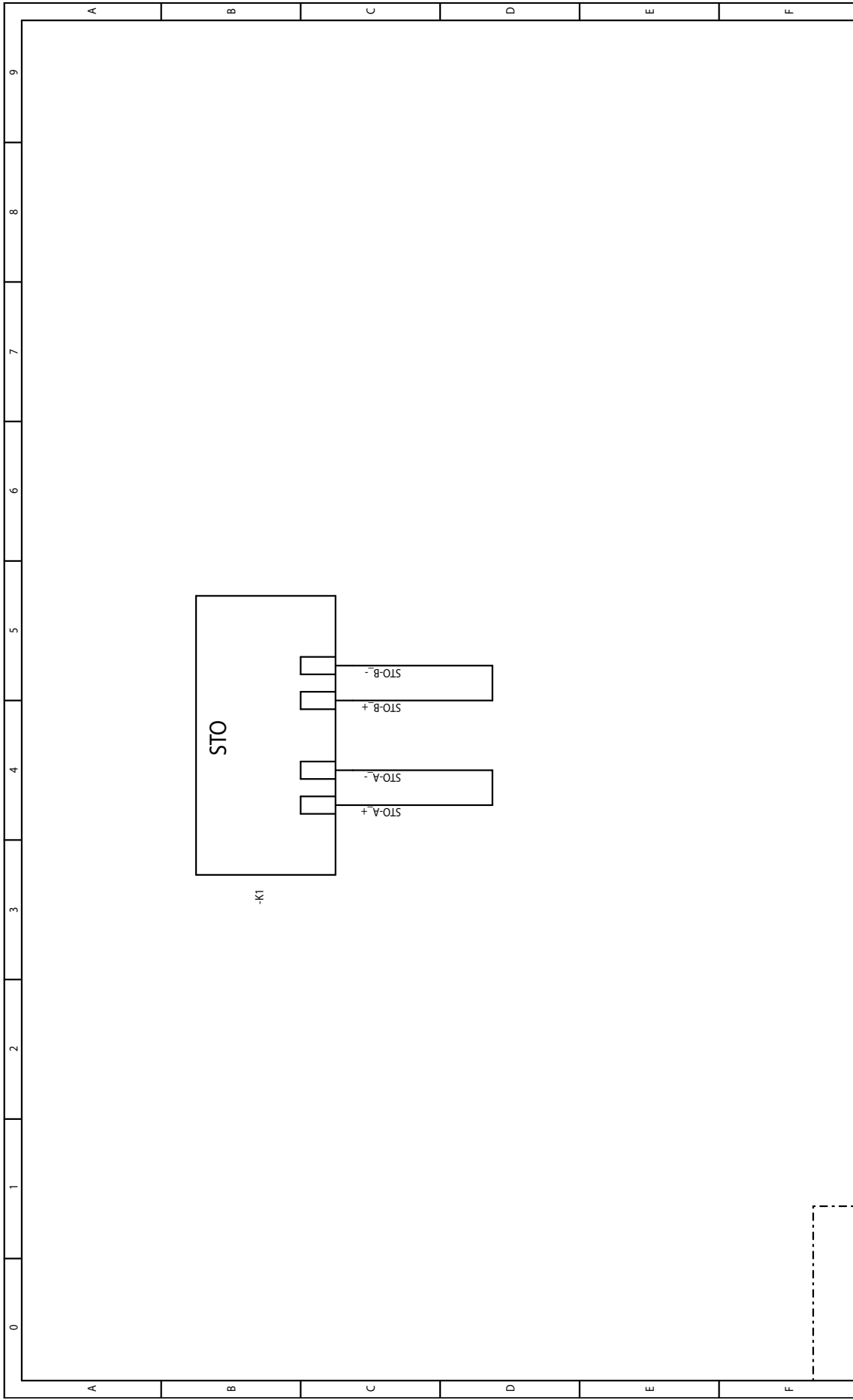

Hybrid 7 Foamtac MA MA2i, MA2IM, MA3i, MA3IM		STO		Dwg. Number 110009267		Init.		DCC		No of pages	
				Date 05-11-2021		Revision A		DCC Next page		Page	
						Project responsible SAN		Next page		Page	
								4		11	
								4		4	

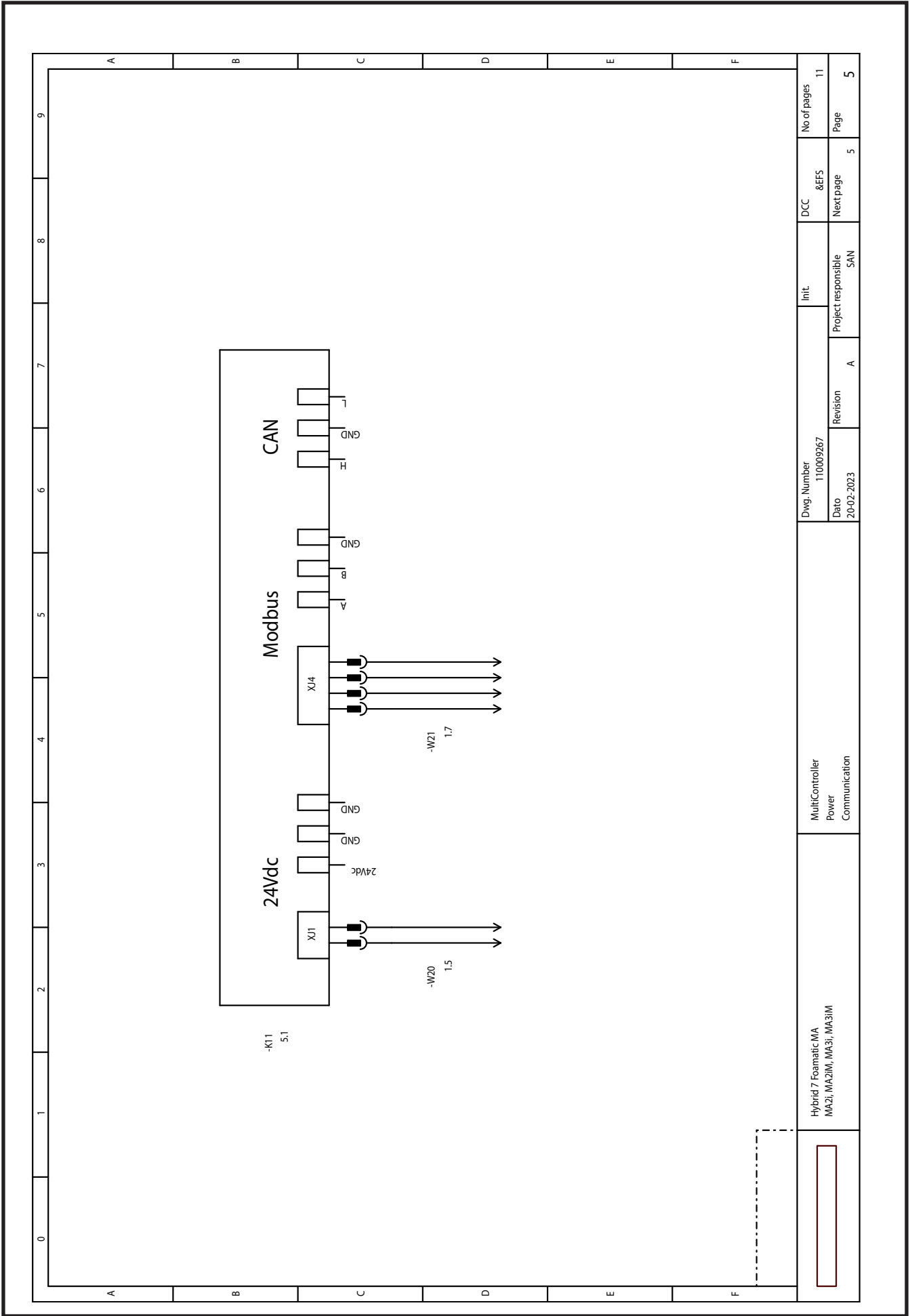

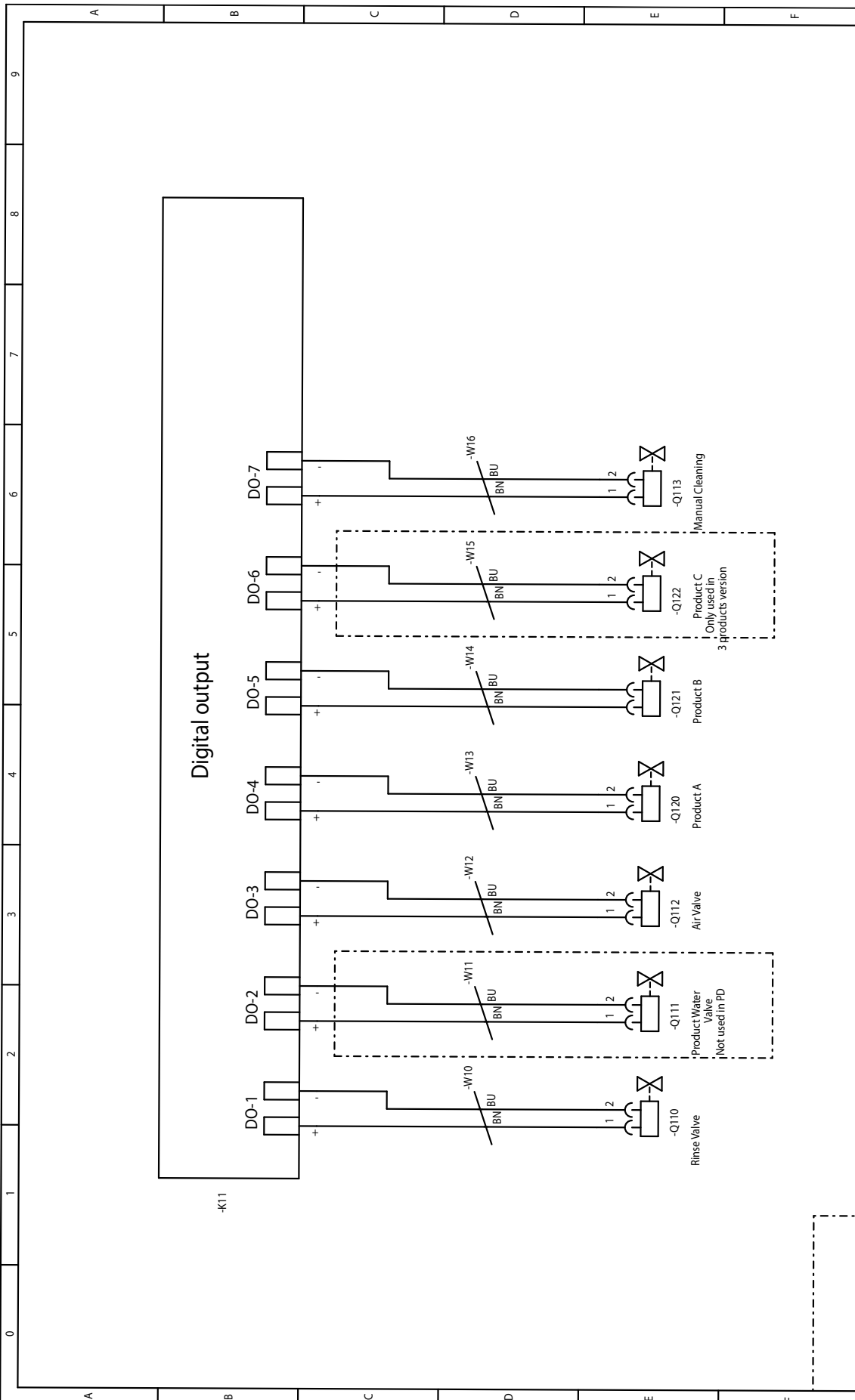

Digital output

<div style="border: 1px solid black; width: 100px; height: 20px; margin: 0 auto;"></div>	Hybrid 7 Foamatic MA MA2I, MA2IM, MA3I, MA3IM		MultiController Outputs		Dwg. Number 110009267		Init.		DCC &EFS		No of pages 11	
	20-02-2023		Revision A		Project responsible SAN		Next page 6		Page 6			

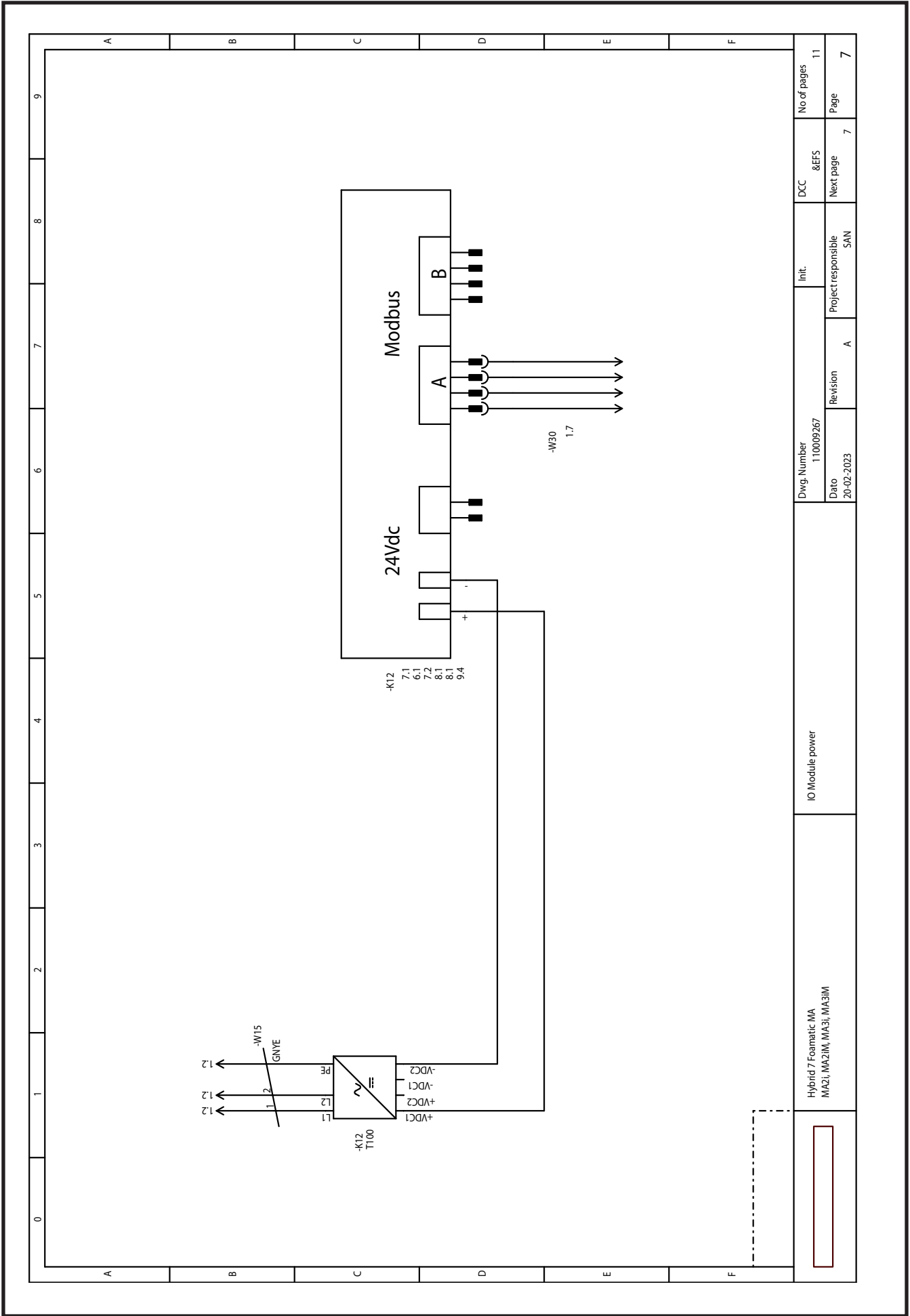

Hybrid 7 Foamatic MA MA2i, MA2M, MA3i, MA3M	IO Module power		Dwg. Number 110009267	Init.	DCC &EFS	No of pages 11
			Date 20-02-2023	Revision A	Project responsible SAN	Next page 7

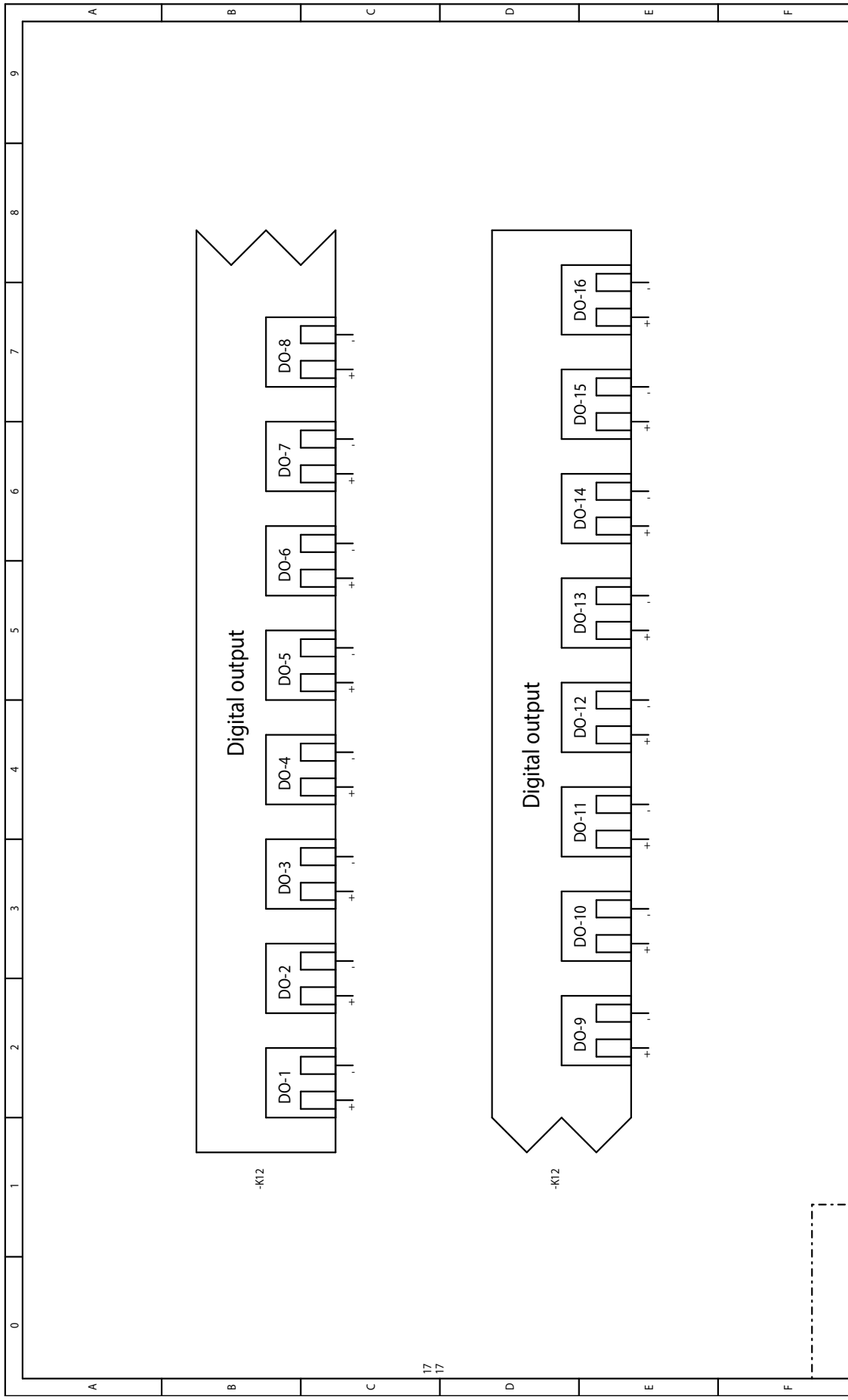

17
17

	Hybrid 7 Foamatic MA MA2i, MA2iM, MA3i, MA3iM	IO Module output		Dwg. Number 110009267	Init.	DCC &EFS	No of pages 11
				Date 20-02-2023	Revision A	Project responsible SAN	Next page 8

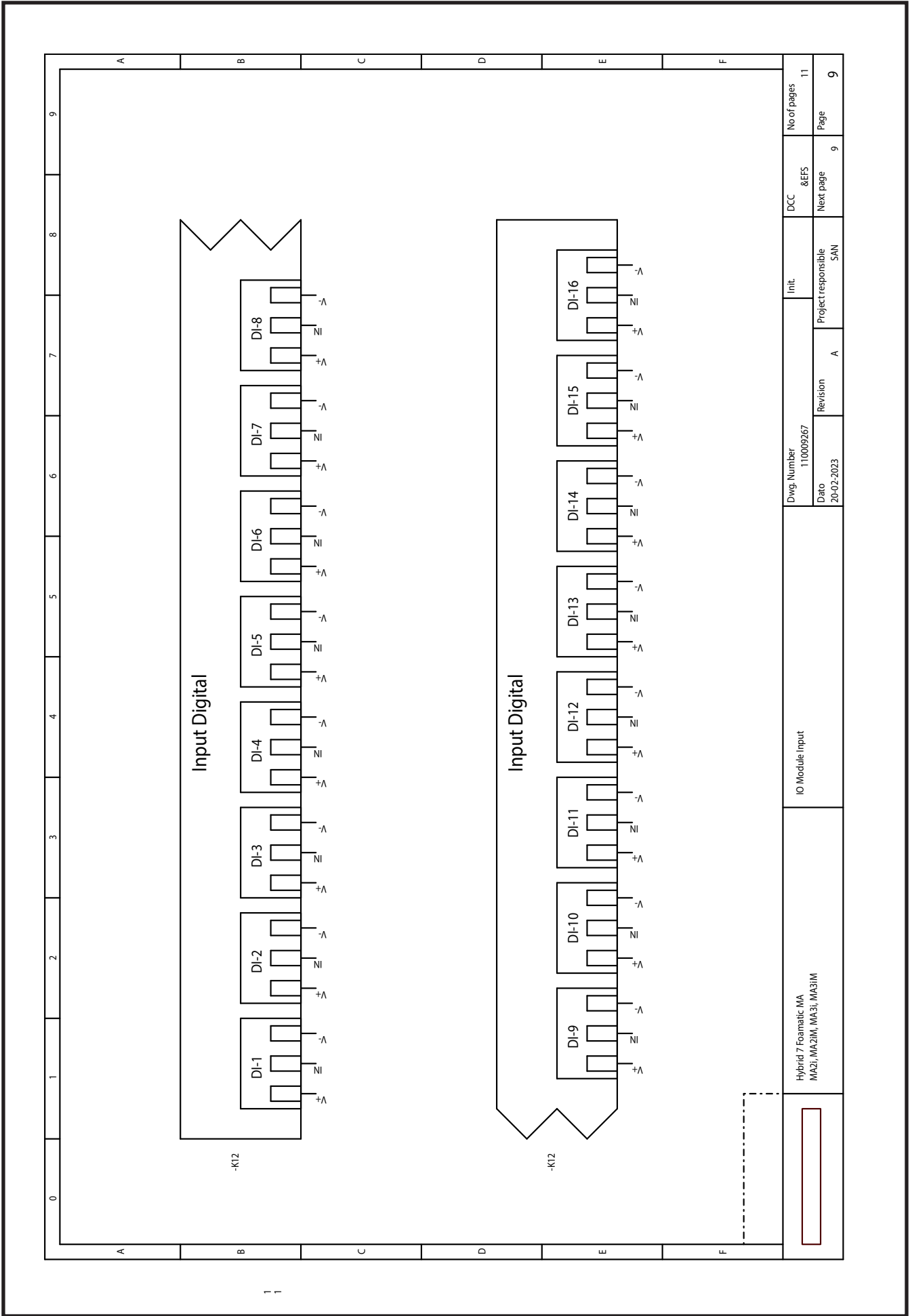

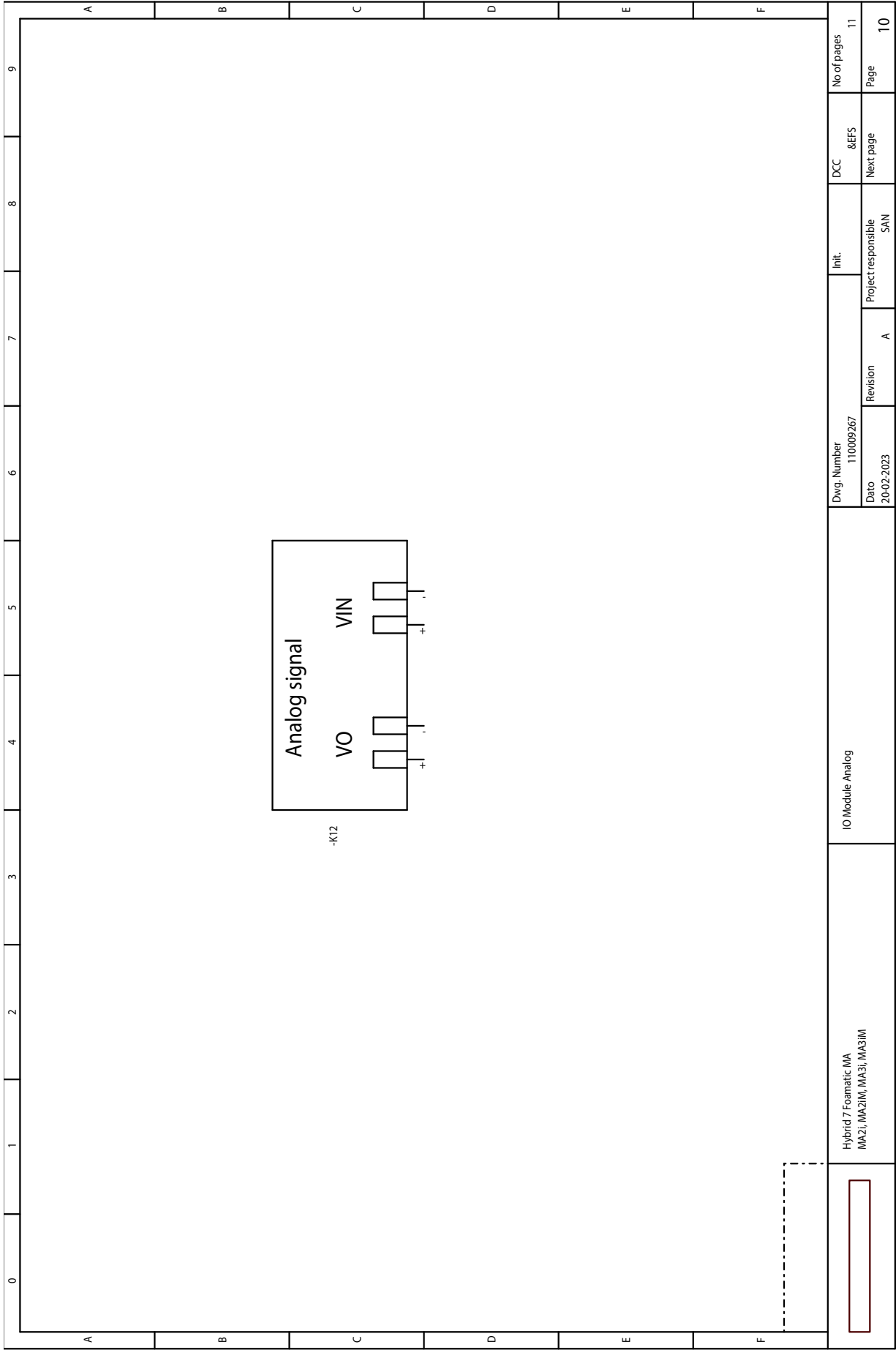

<div style="border: 1px solid black; width: 100px; height: 20px; margin-bottom: 5px;"></div> Hybrid 7 Foamatic, MA MA2i, MA2IM, MA3i, MA3IM	IO Module Analog		Dwg. Number 11009267		Init.		DCC &EFS		No of pages 11		
			Revision A		Project responsible SAN		Next page		Page 10		
Date 20-02-2023											

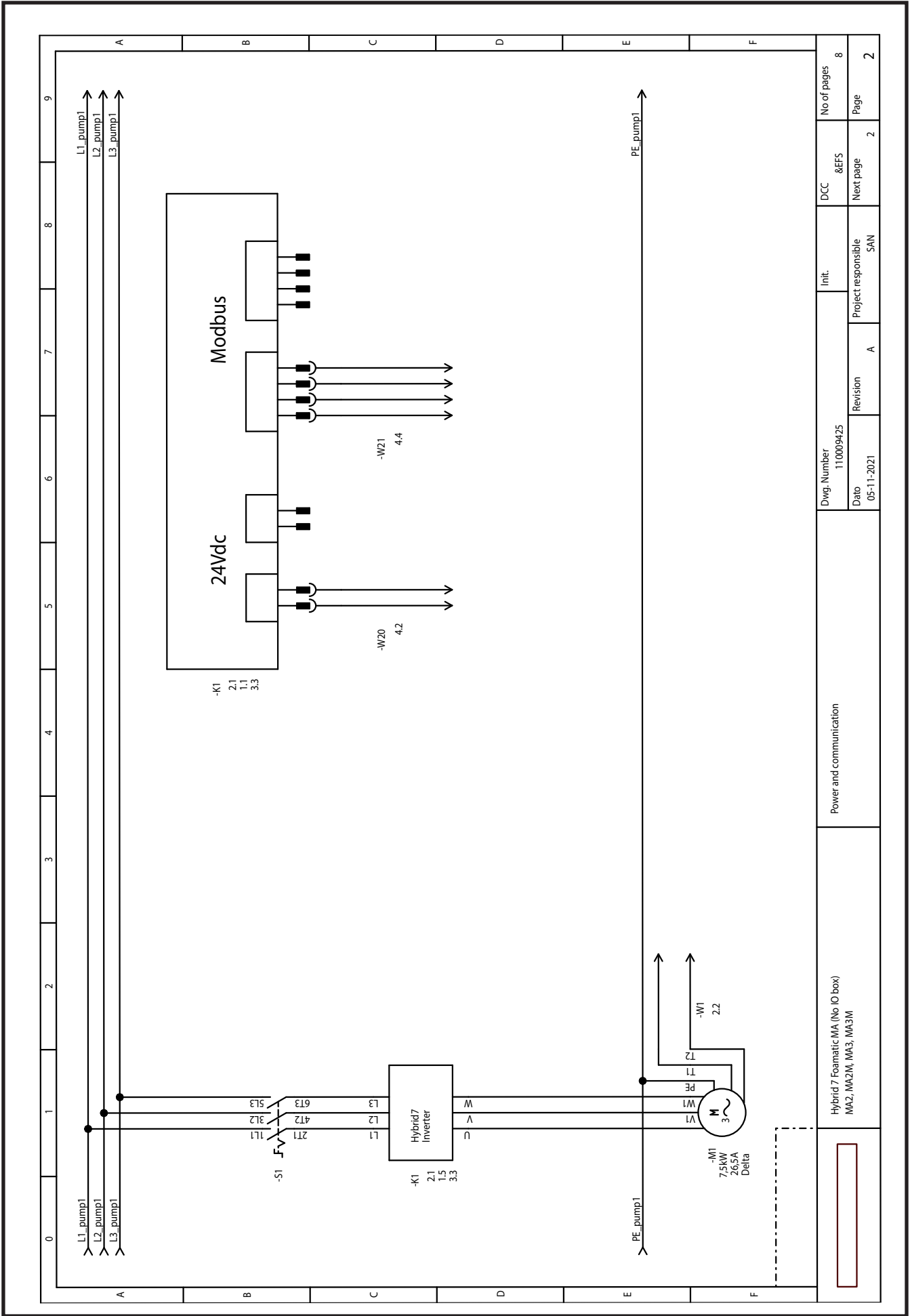

Dwg. Number 110009425		DCC		No of pages 8	
Date 05-11-2021		Revision A		Page 2	
Init.		Project responsible SAN		Next page 8	
Power and communication		DCC 8EFS		Page 2	
Hybrid 7 Foamatic MA (No IO box) MA2, MA2M, MA3, MA3M		Init.		No of pages 8	
		Project responsible SAN		Page 2	

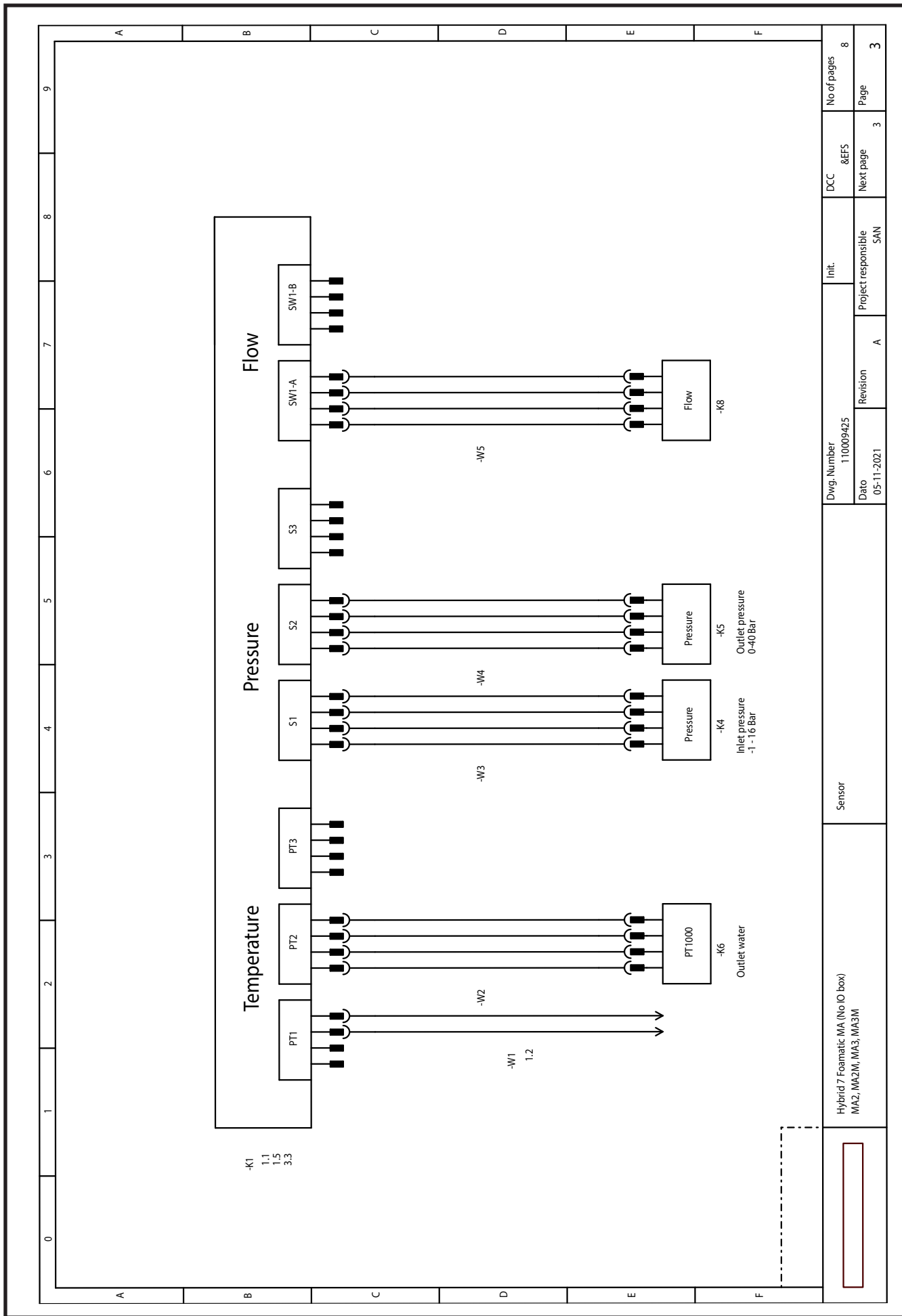

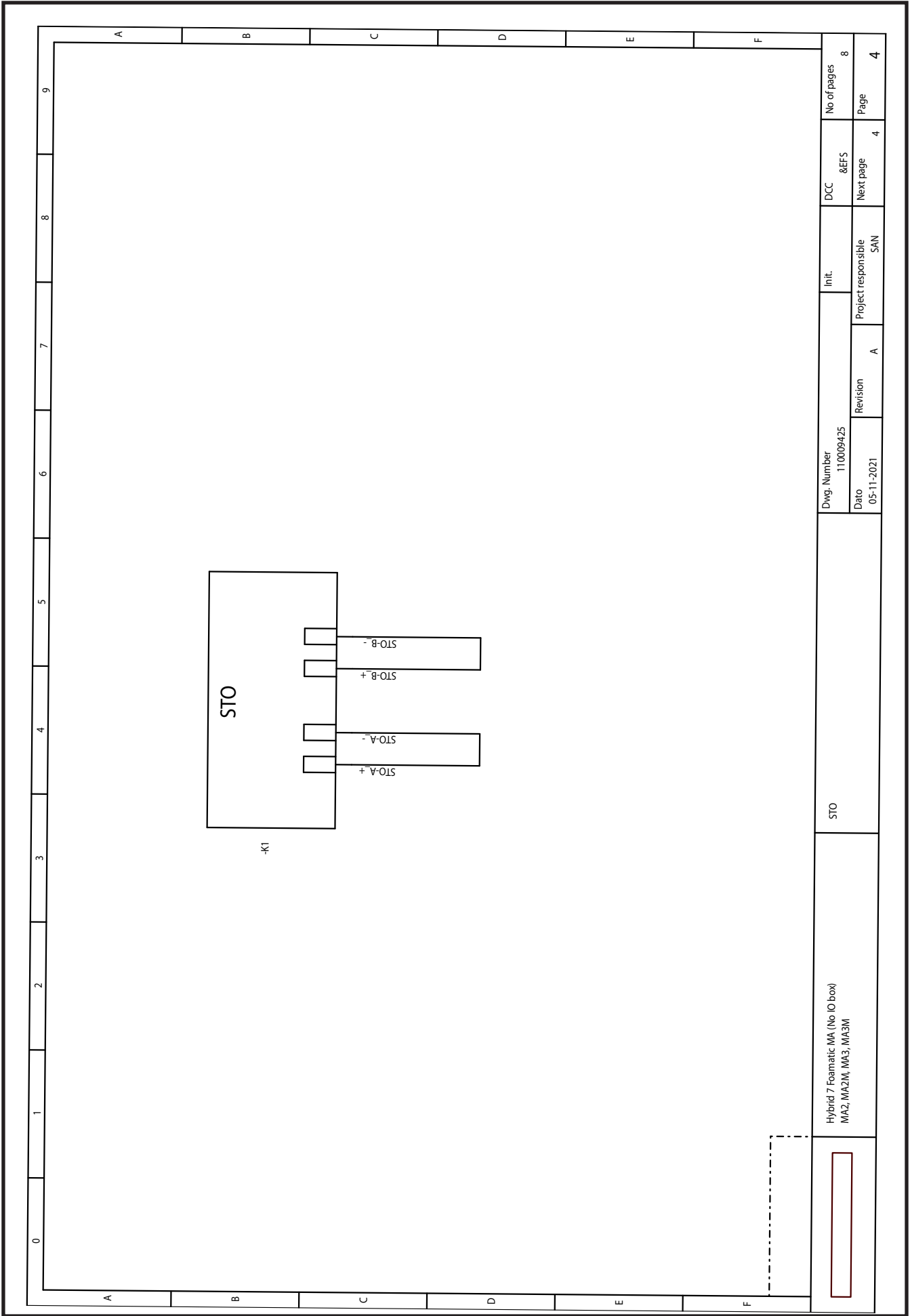

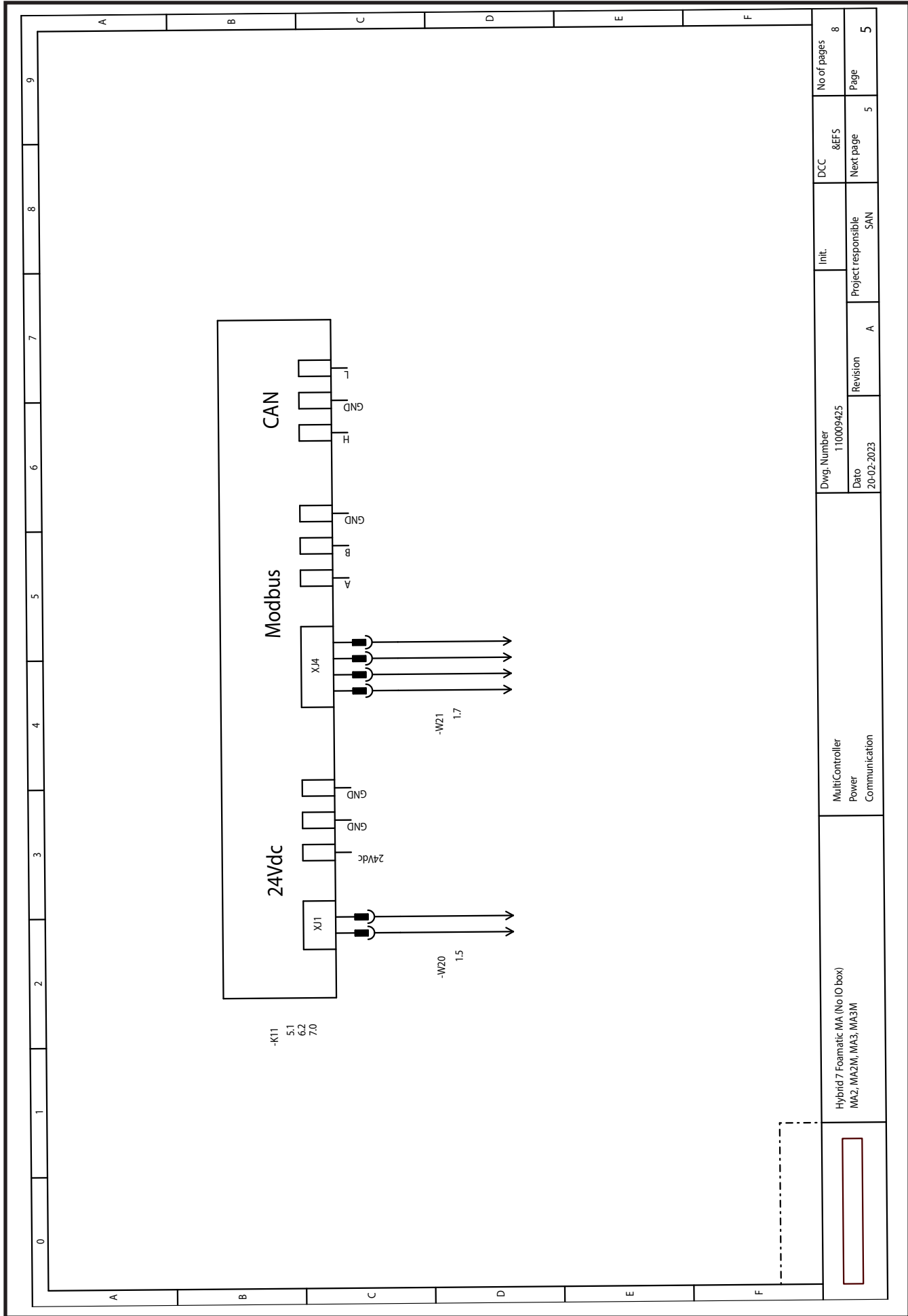

Hybrid 7 Foamatic MA (No IO box) MA2, MA2M, MA3, MA3M		MultiController Power Communication		Dwg. Number 110009425		Init.		DCC		No of pages	
				Date 20-02-2023		Revision A		Next page SAN		Page	
								Next page 5		5	

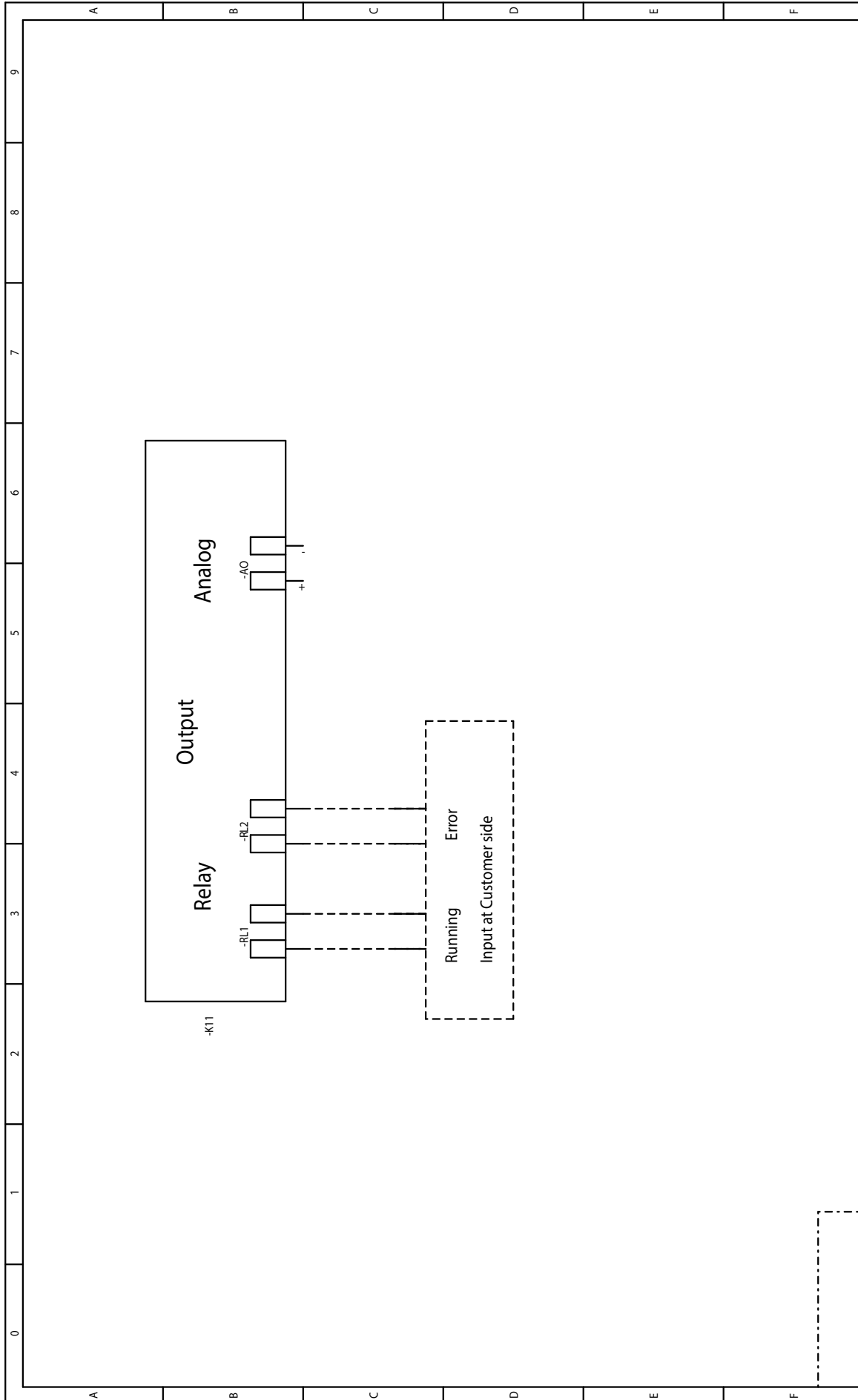

Hybrid 7 Foamatic MA (No IO box) MA2, MA2M, MA3, MA3M		MultiController Relays and Analog Out		Dwg. Number 110009425		Init.		DCC		No of pages	
				Date 14-04-2023		Project responsible SAN		Next page		Page	
				Revision A				7		7	

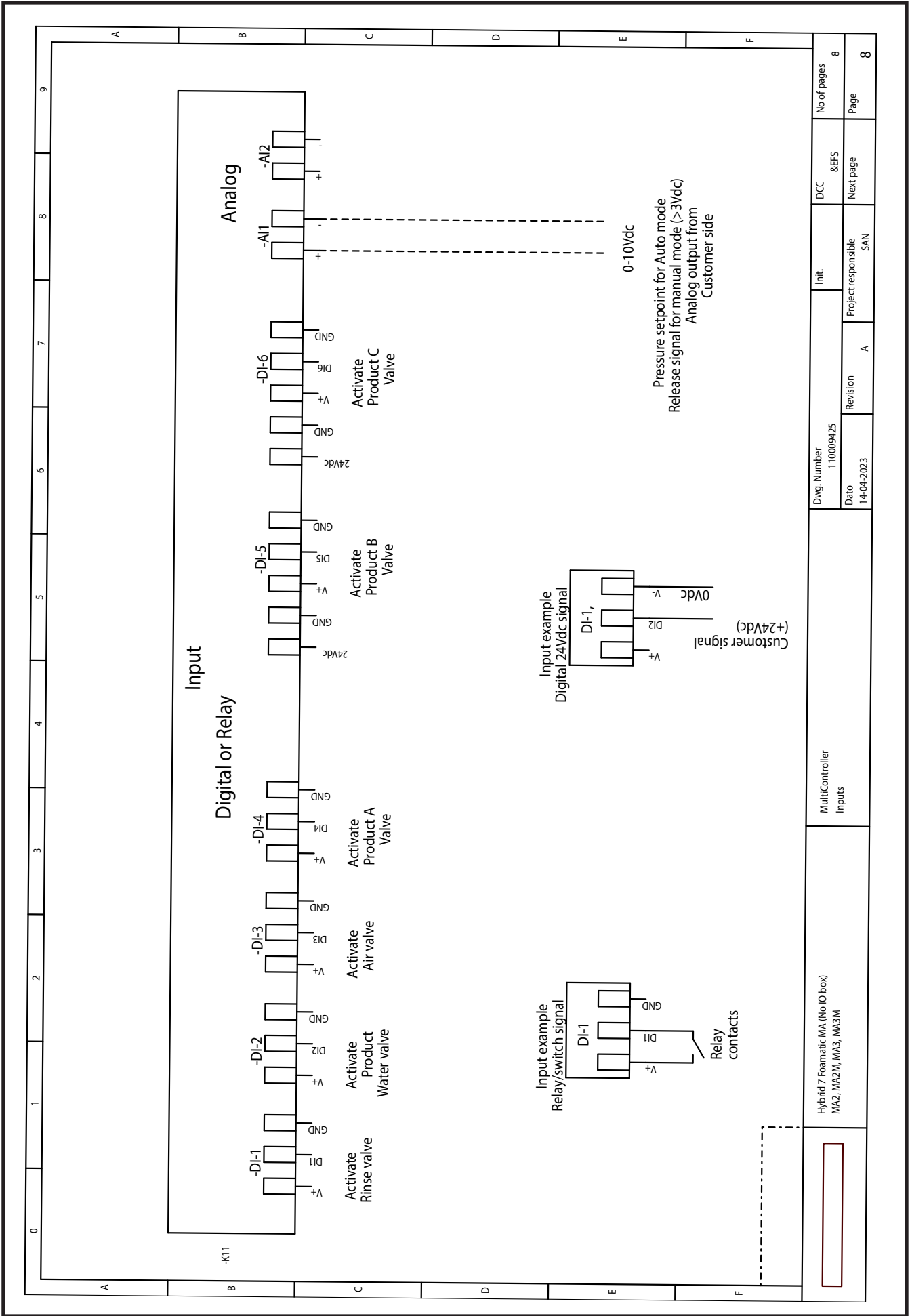

Hybrid 7 Foamatec MA (No IO box) MA2, MA2M, MA3, MA3M		Multicontroller Inputs		Dwg. Number 110009425		Init.		DCC &EFS		No of pages 8	
				Date 14-04-2023		Revision A		Project responsible SAN		Next page Page 8	

11.5. Pump curve

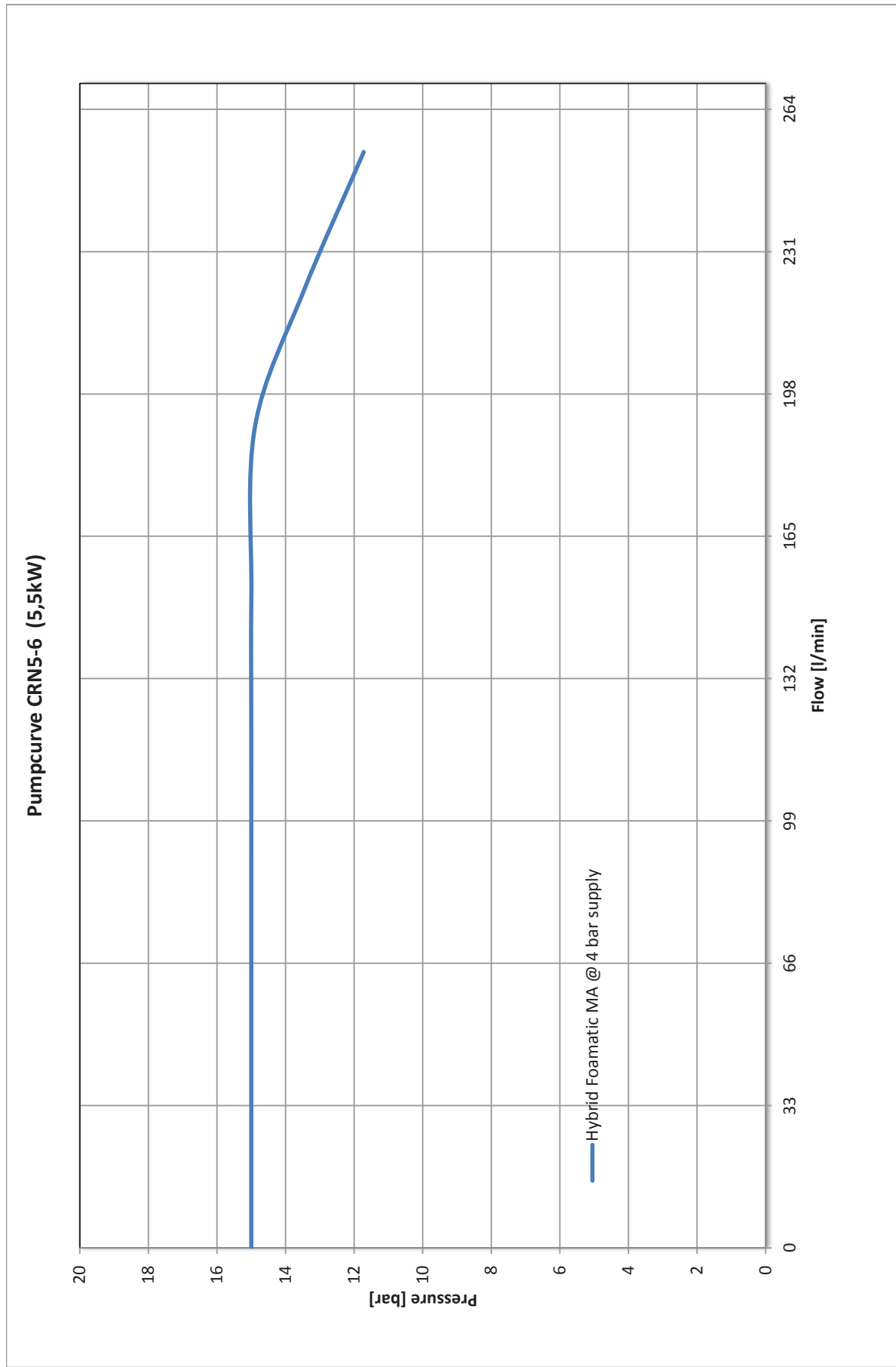

12. Sensors & diagrams SA

12.1. Operating Diagram SA

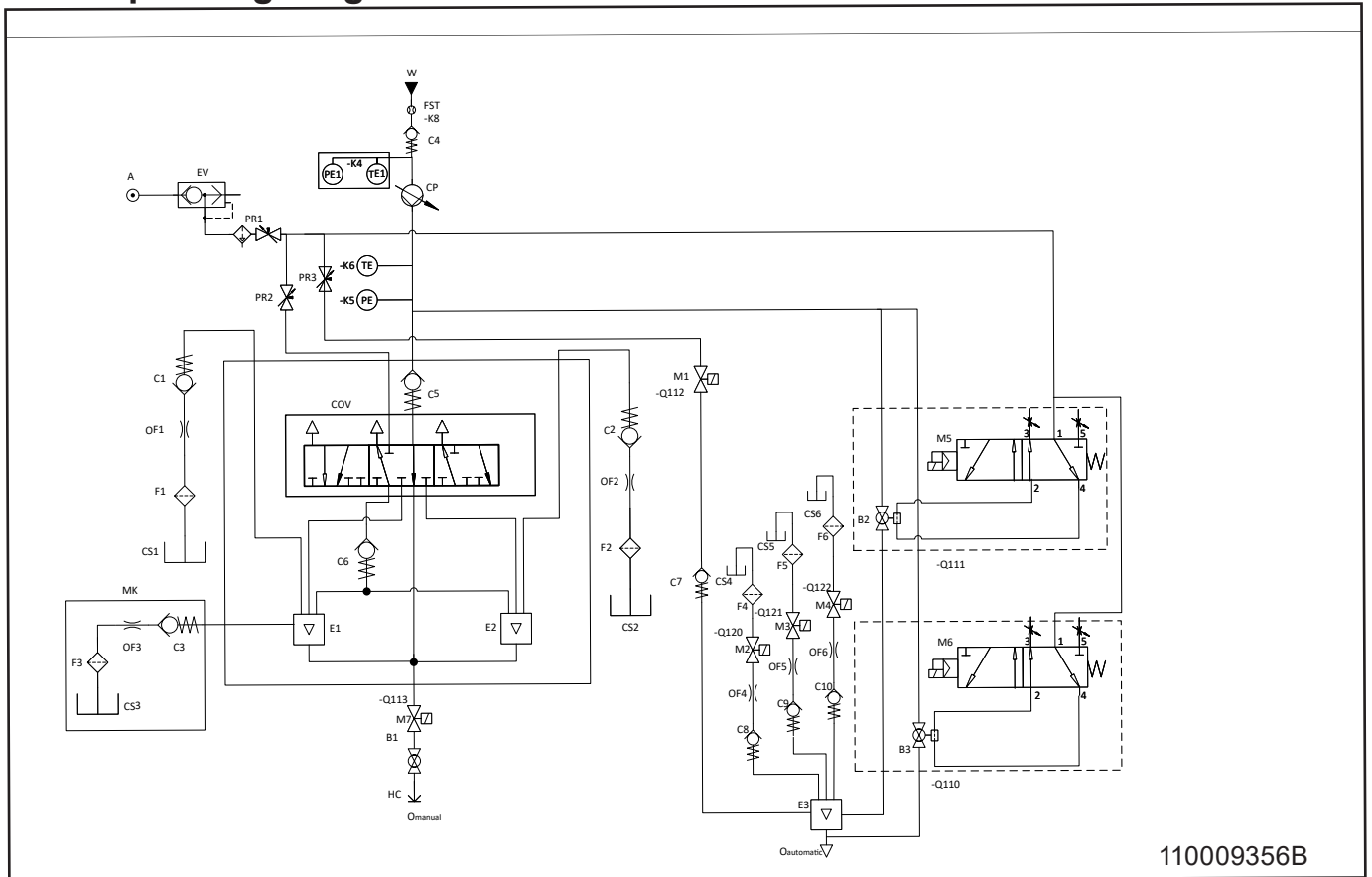

	English	Deutsch	Français	Español	Italian
A	Air supply	Lufteingang	Alimentation air	Suministro de aire	Alimentazione dell'aria
B	Ball valve	Kugelventil	Clapet à bille	Válvula esférica	Valvola a sfera
C	Check valve	Rückschlagventil	Soupape de non retour	Válvula de retención	Valvola di ritegno
COV	Change over valve	Umschaltventil	Robinet coupleur	Válvula de conmutación	Valvola di commutazione
CP	Centrifugal pump	Kreiselpumpe	Pompe Centrifuge	Bomba centrífuga	Pompa centrifuga
CS	Product supply	Chemische Versorgung	Fourniture de produits chimiques	Toma de suministro de productos químicos	Fornitura di prodotti
E	Ejector	Ejektor	Ejecteur	Eyector	Espulsore
EV	Exhaust valve	Auslassventil	La soupape d'échappement	Válvula de escape	Valvola di scarico
F	Filter	Filter	Filtre	Filtro	Filtro
FST	Flow sensor and -trigger	Durchflusssensor und auslöser	Captur de débit et de déclenchement	Sensor de caudal y de activación	Sensore di flusso e grilletto
HC	Hose coupling	Schlangenverbindung	Connexion flexible	Conexión de tubo flexible	Attacco tubo flessibile
K	Component reference	Komponentenreferenz	Référence composant	Referencia del componente	Riferimento componente
M	Magnetic valve	Magnetventil	Vanne magnétique	Válvula magnética	Valvola magnetica
MK	Mix kit (Optional)	Misch-Kit (Optional)	Kit de mélange (Optionnel)	Kit de mezcla (Opcional)	Kit di mix (facoltativo)
O	Outlet	Ausgang	Sortie	Salida	Preso
OF	Orifice	Blende	Orifice	Orificio	Orifizio
PE	Pressure sensor	Drucksensor	Captur de pression	Sensor de presión	Sensore di pressione
PR	Pressure regulator	Druckregler	Régulateur de pression	Régulador de presión	Regolatore di pressione
TE	Temperature sensor	Temperatursensor	Captur de température	Sensor de temperatura	Termometro
CO	Component reference	Komponentenreferenz	Référence composant	Referencia del componente	Riferimento componente
W	Water inlet	Wasserzufluss	Arrivée d'eau	Entrada de agua	Ingresso acqua

12.2. Electrical ratings SA

IO module		
Output ratings		
Max. load single output	A	0.8
Max load sum of all outputs	A	3.2
Voltage nom.	V	24
Voltage min.	V	22
Voltage max.	V	24.5
Input ratings		
Input voltage nom.	V	24
Min. input voltage on	V	22
Max. input voltage on	V	25
Max. input voltage off	V	2

12.3. Component location SA

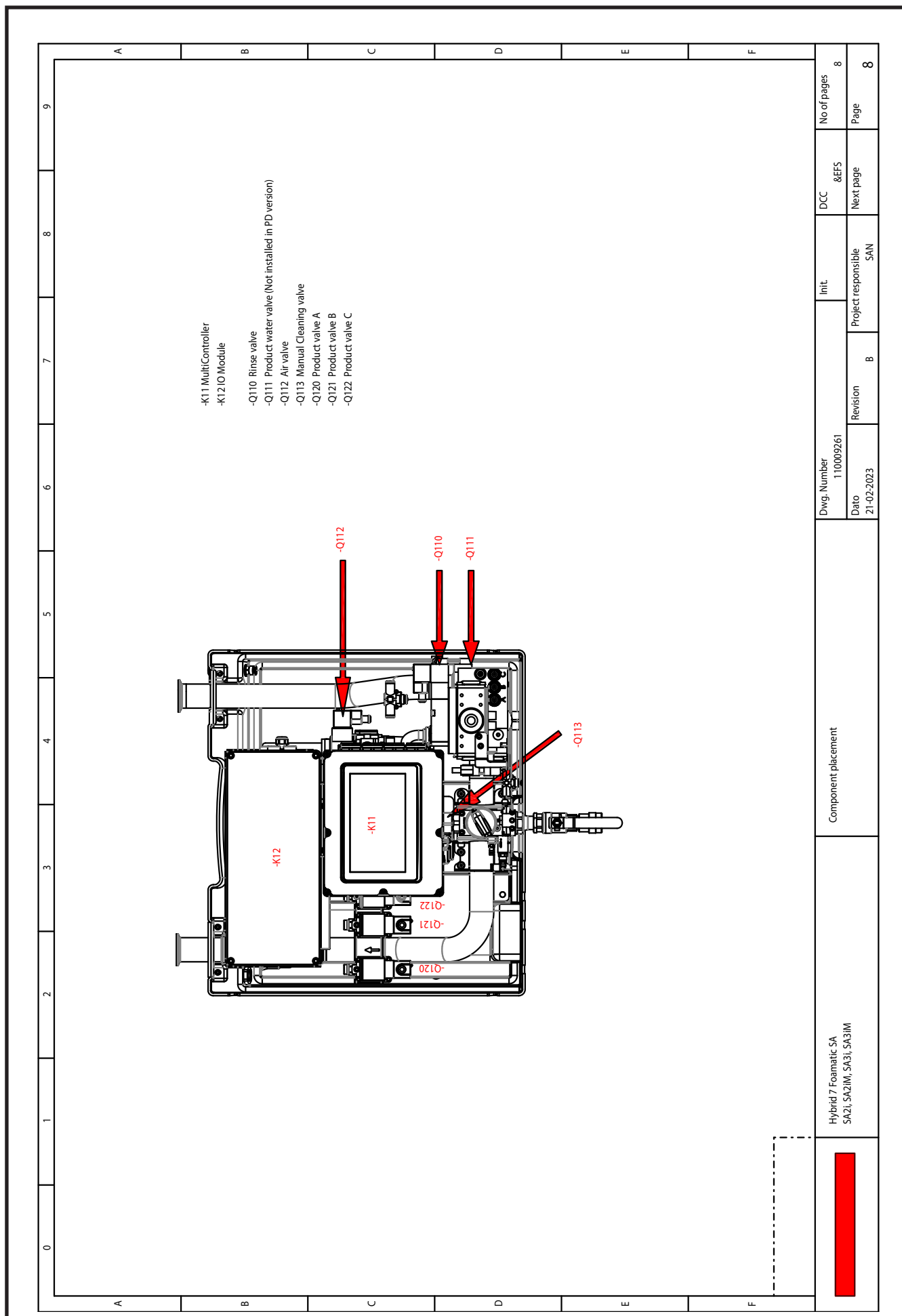

Hybrid 7 Foamatic SA SA2i, SA2IM, SA3i, SA3IM	Component placement		Dwg. Number 110009261	Init.	DCC &EFS	No of pages 8
			Date 21-02-2023	Revision B	Project responsible SAN	Page 8

12.4. Circuit diagrams & sensor diagrams SA

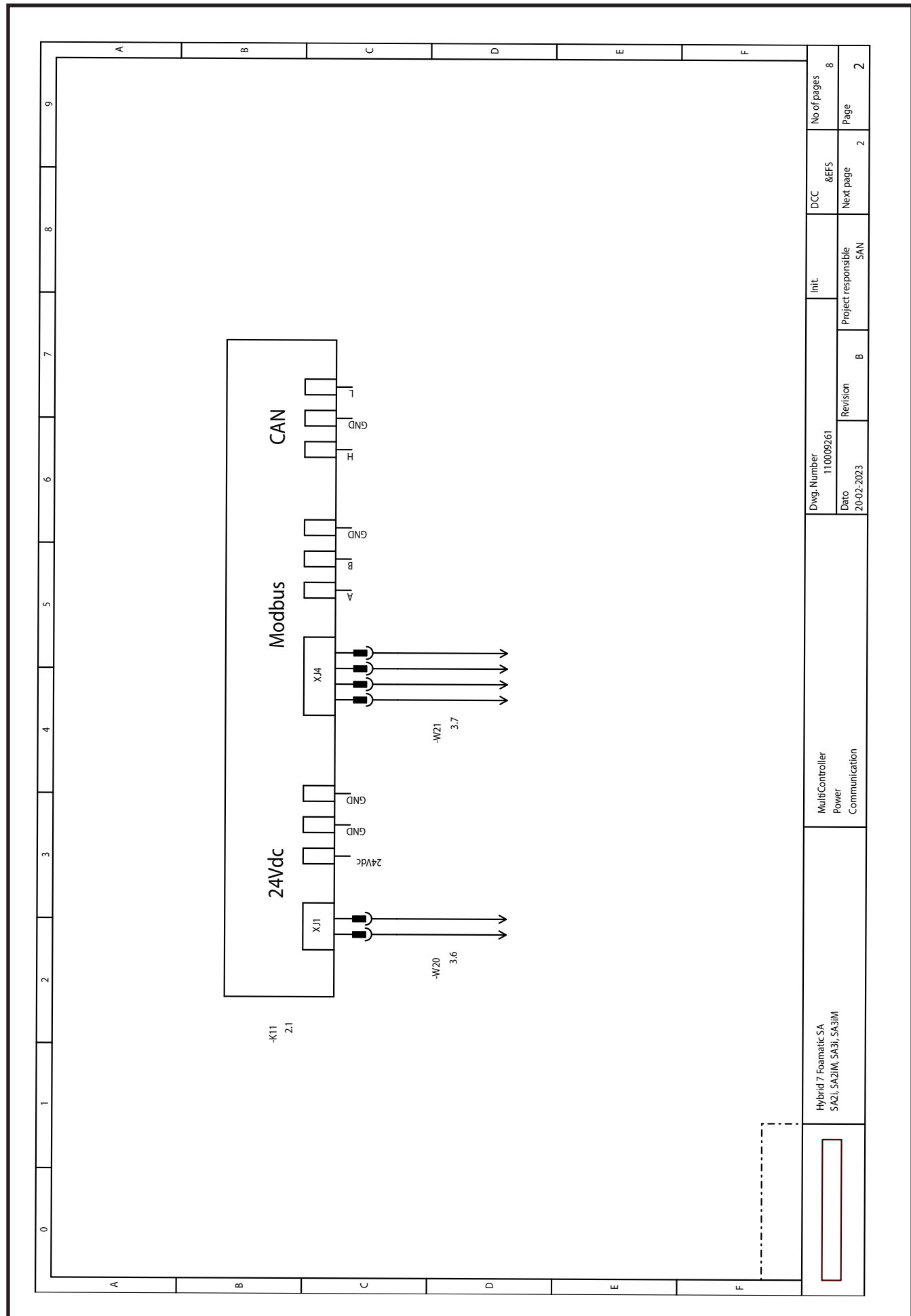

Hybrid 7 Foamatic SA SA2J, SA2JM, SA3J, SA3JM	MultiController Power Communication		Dwg. Number 110009261		Init.		DCC &EFS		No. of pages 8	
			Date 20-02-2023		Revision B		Project responsible SAN		Page 2	

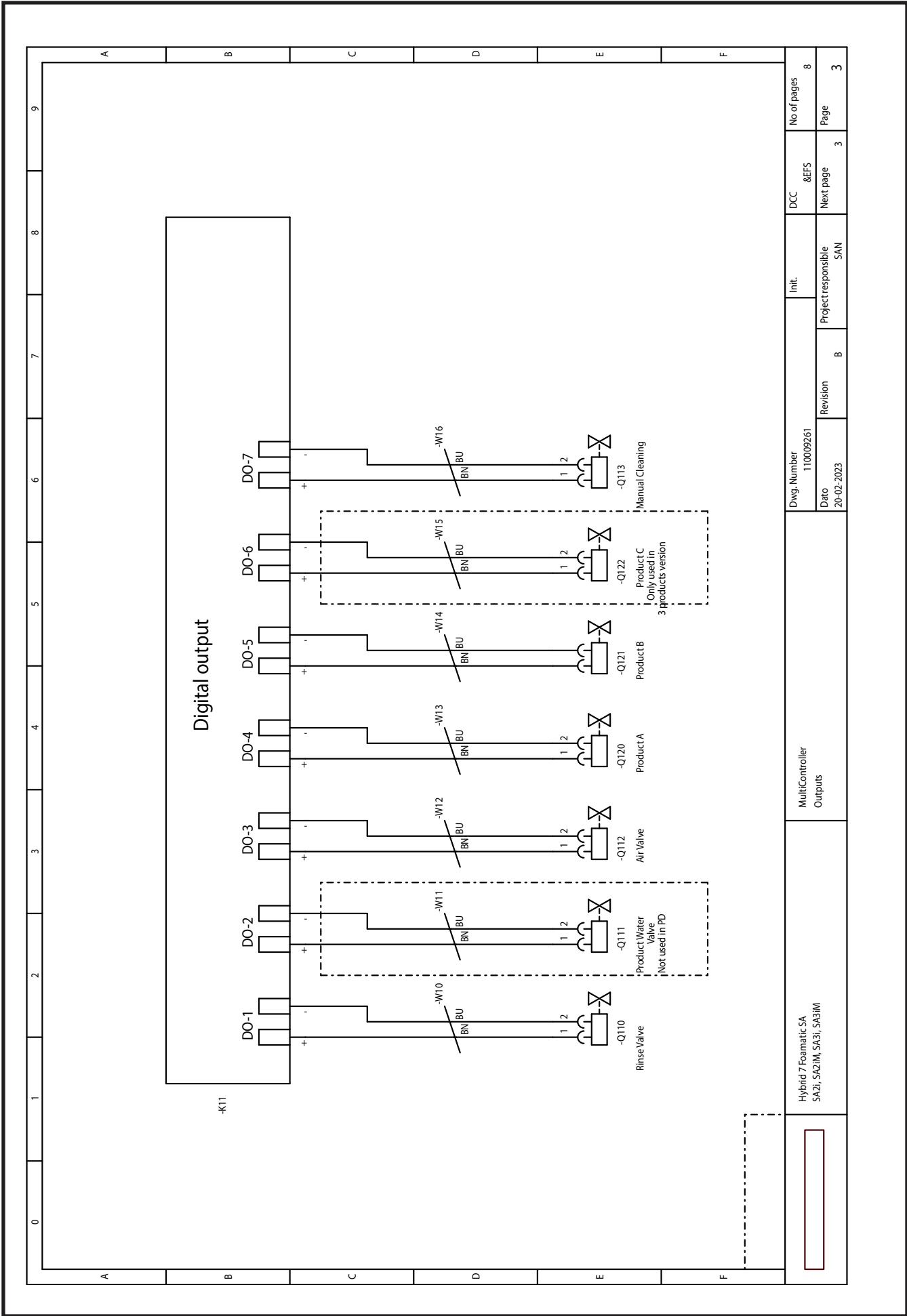

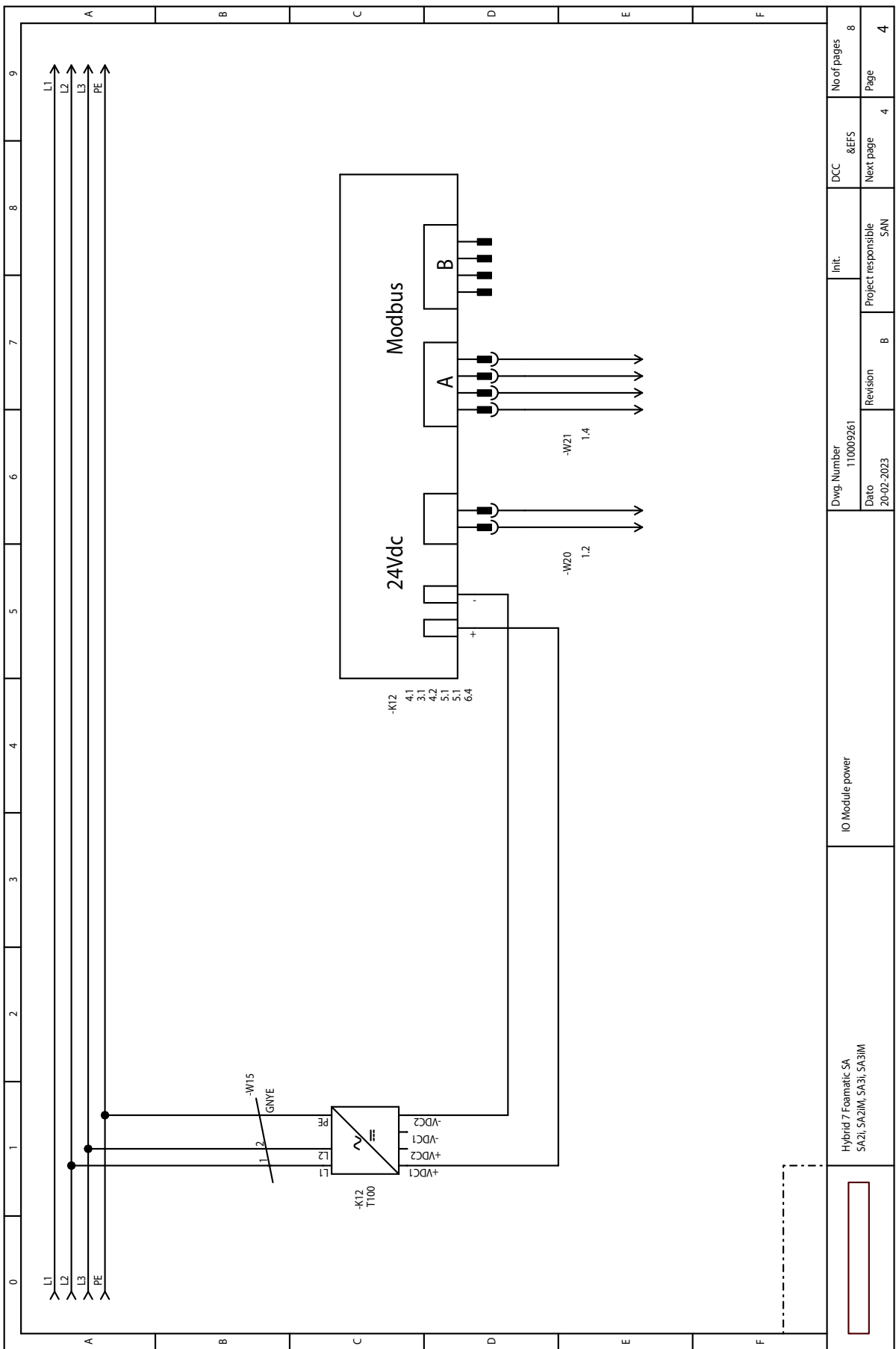

<div style="border: 1px solid black; width: 100px; height: 20px; margin-bottom: 5px;"></div> Hybrid 7 Foematic SA SA.2i, SA.2M, SA.3i, SA.3IM	IO Module power		Dwg Number 110009261	Init.	DCC	No of pages 8
			Date 20-02-2023	Revision B	Project responsible SAN	Next page 4
						Page 4

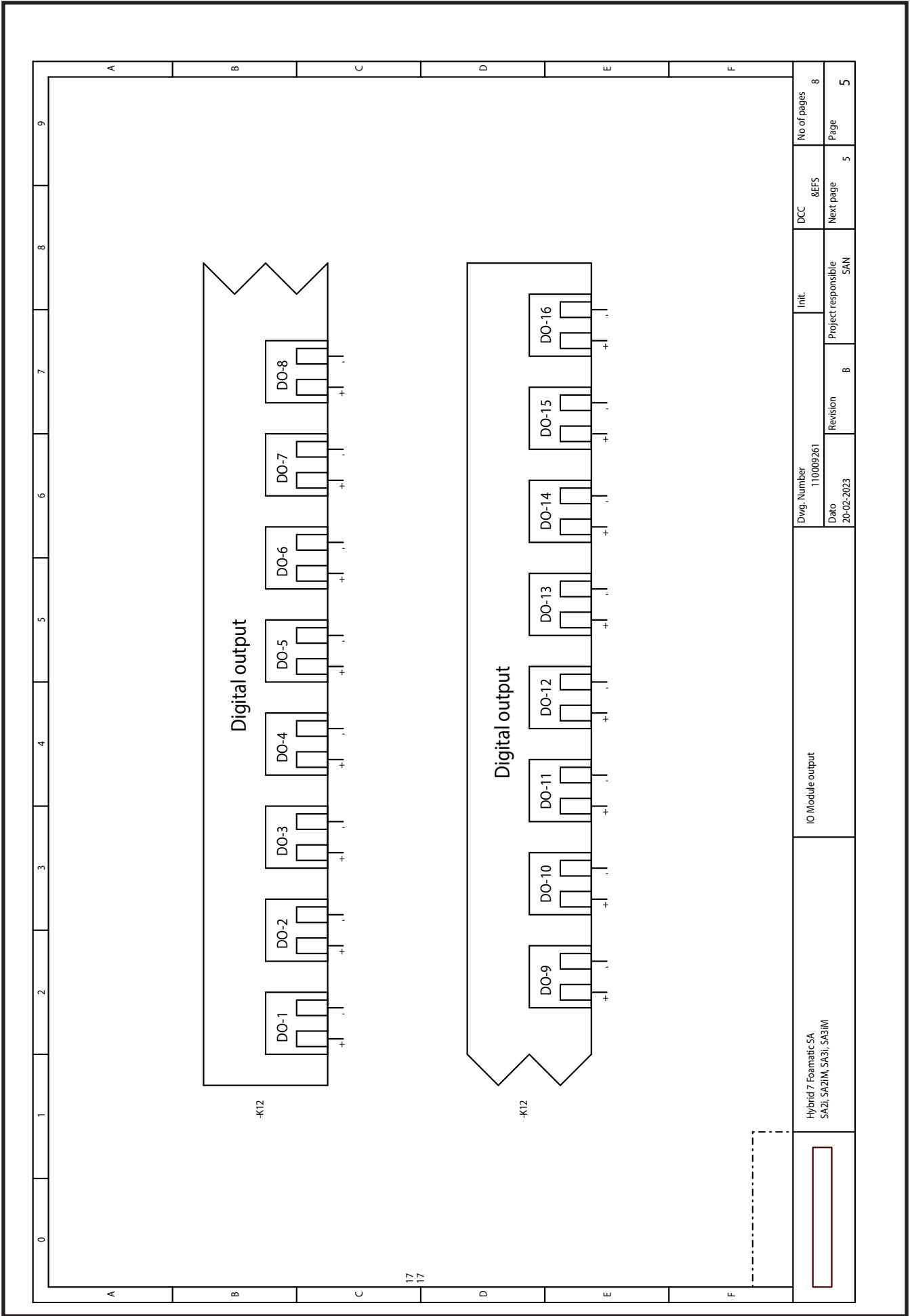

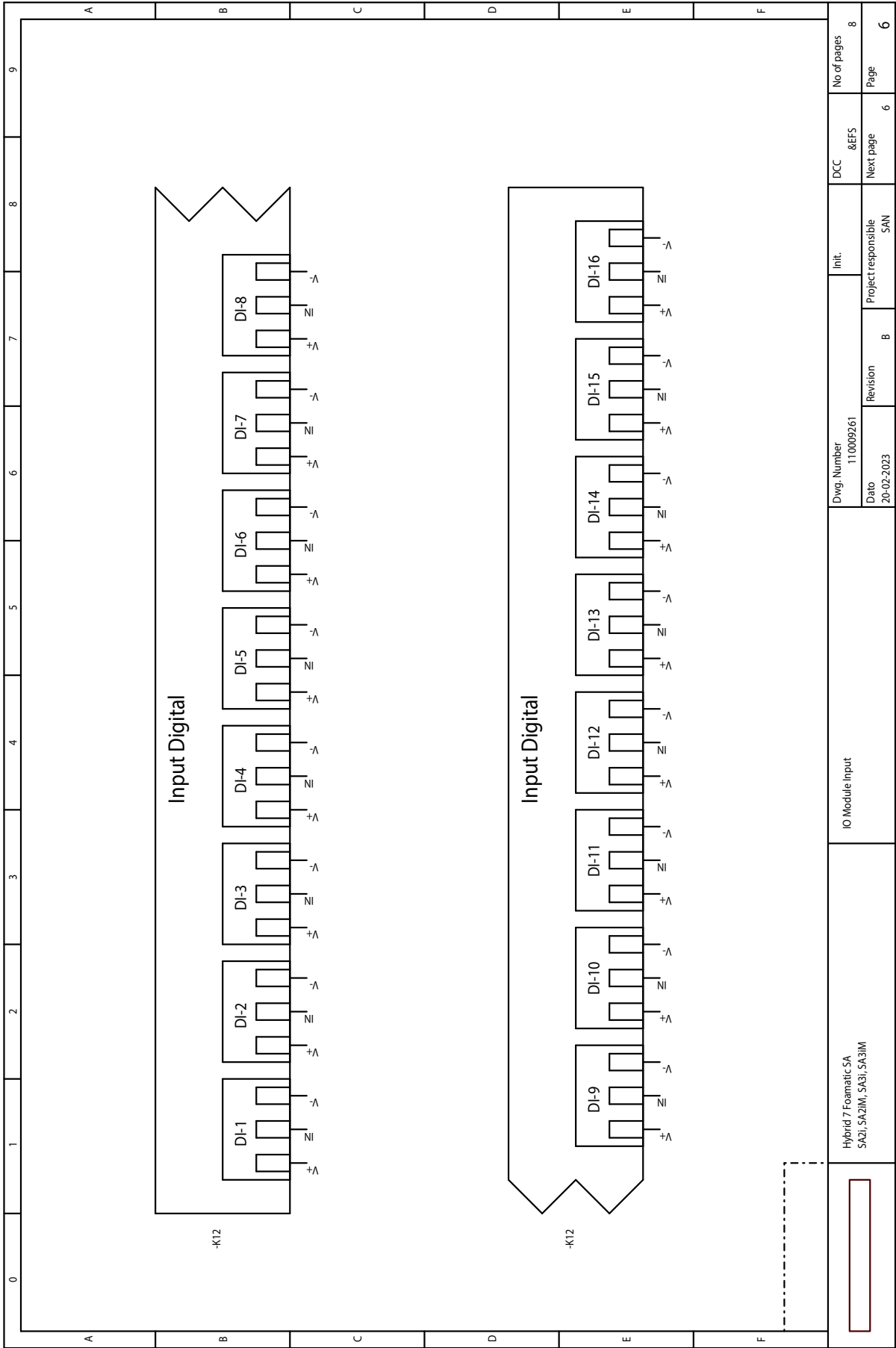

<div style="border: 1px solid black; width: 50px; height: 20px; margin: 0 auto;"></div>	Hybrid 7 Foamatic SA SA2i, SA2IM, SA3i, SA3IM		IO Module Input		Dwg. Number 110009261		Init.		DCC &EFS		No of pages 8	
	Date 20-02-2023		Revision B		Project responsible SAN		Next page 6		Page 6			

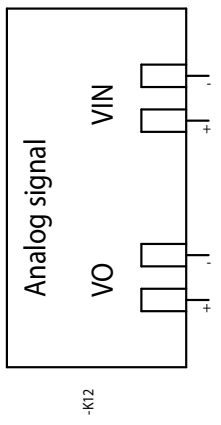
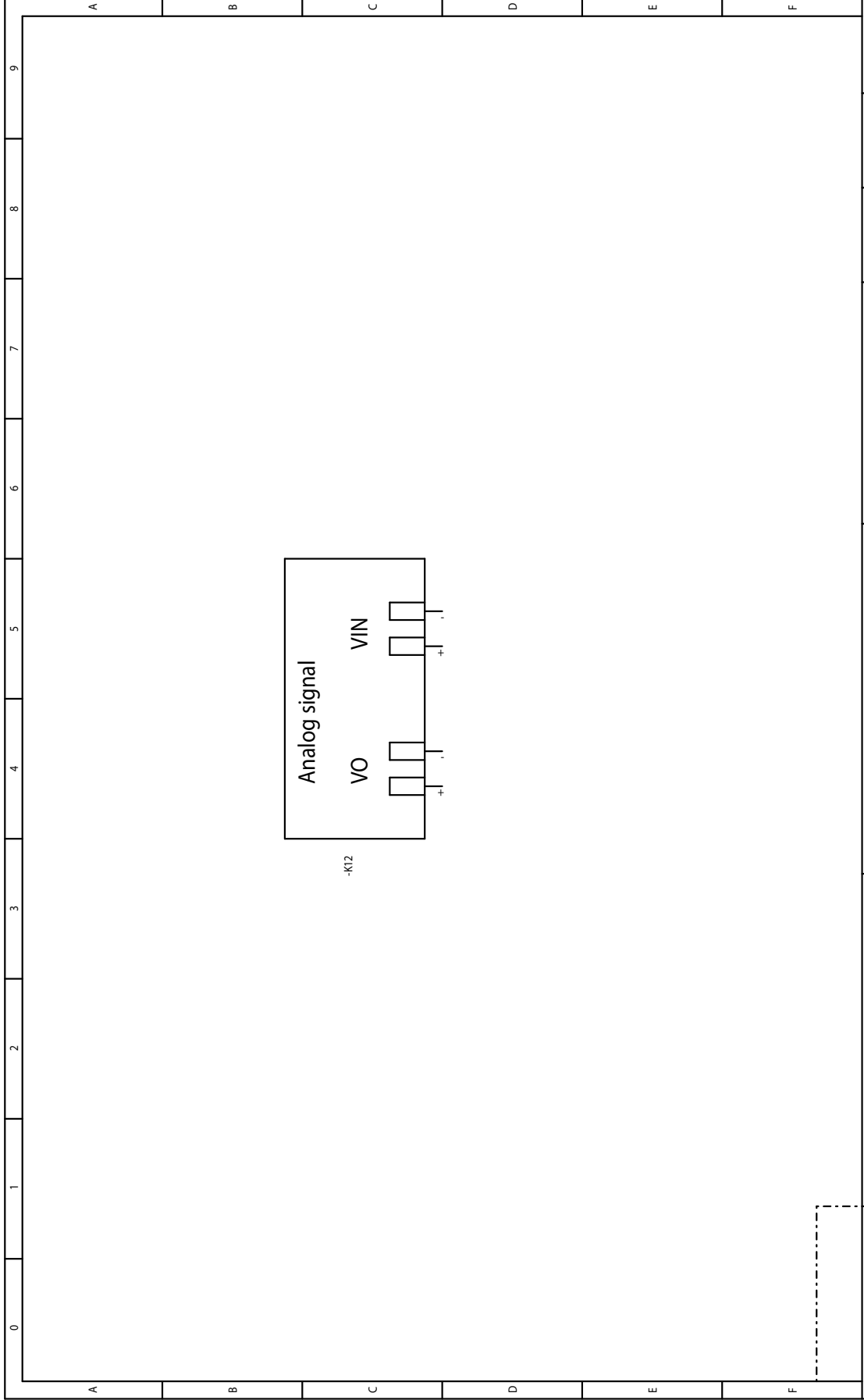

<div style="border: 1px solid black; width: 100px; height: 20px; margin-bottom: 5px;"></div> Hybrid 7 Foamatec SA SA2i, SA2IM, SA3i, SA3IM	IO Module Analog		Dwg. Number 110009261		Init.		DCC		No of pages		
			Date 20-02-2023		Revision B		Project responsible SAN		Next page		Page 7

13. Installation, mounting & layout

Hybrid 7 Foamatic MA & SA

13.1. Installation & mounting MA

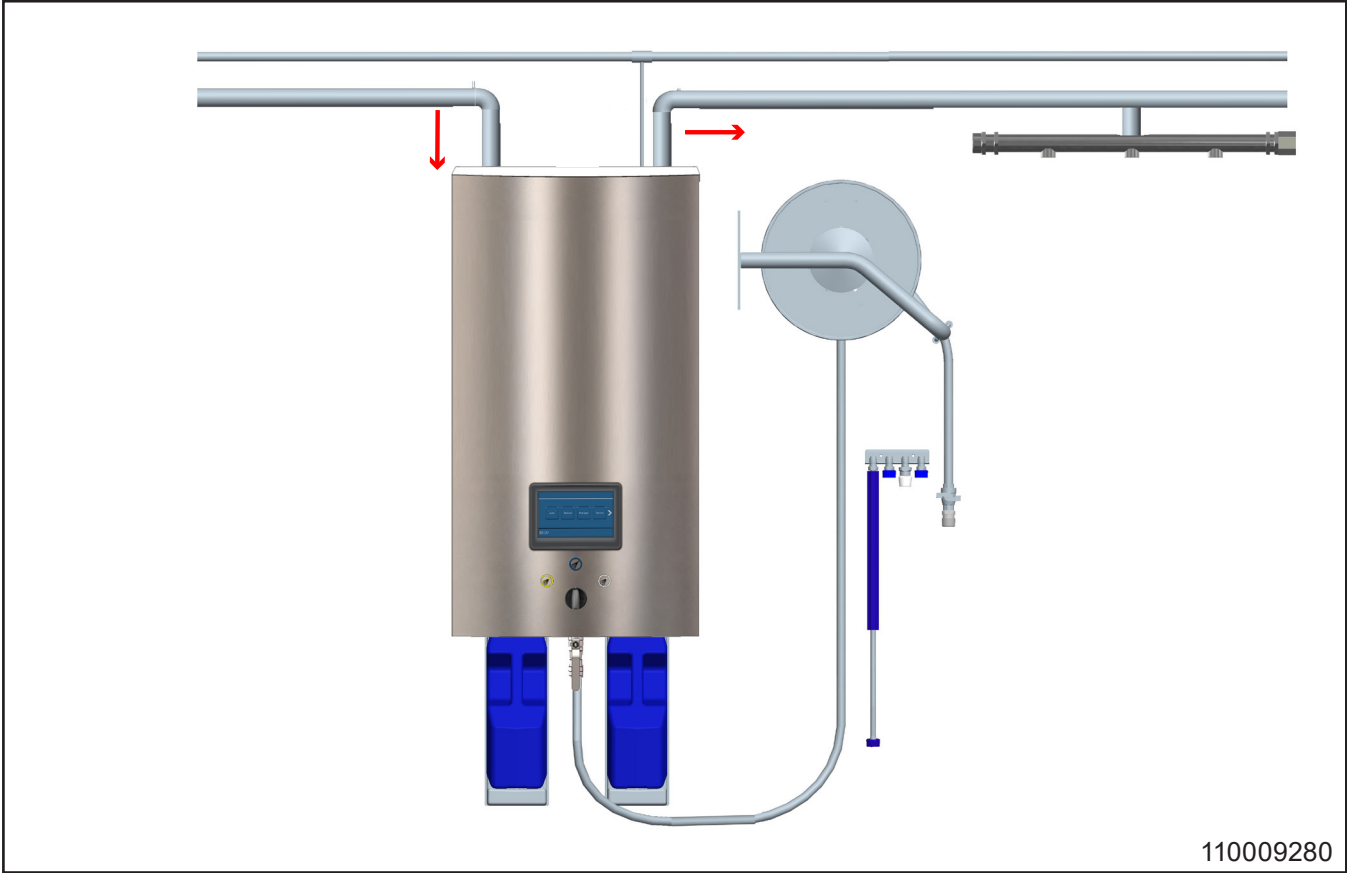

110009280

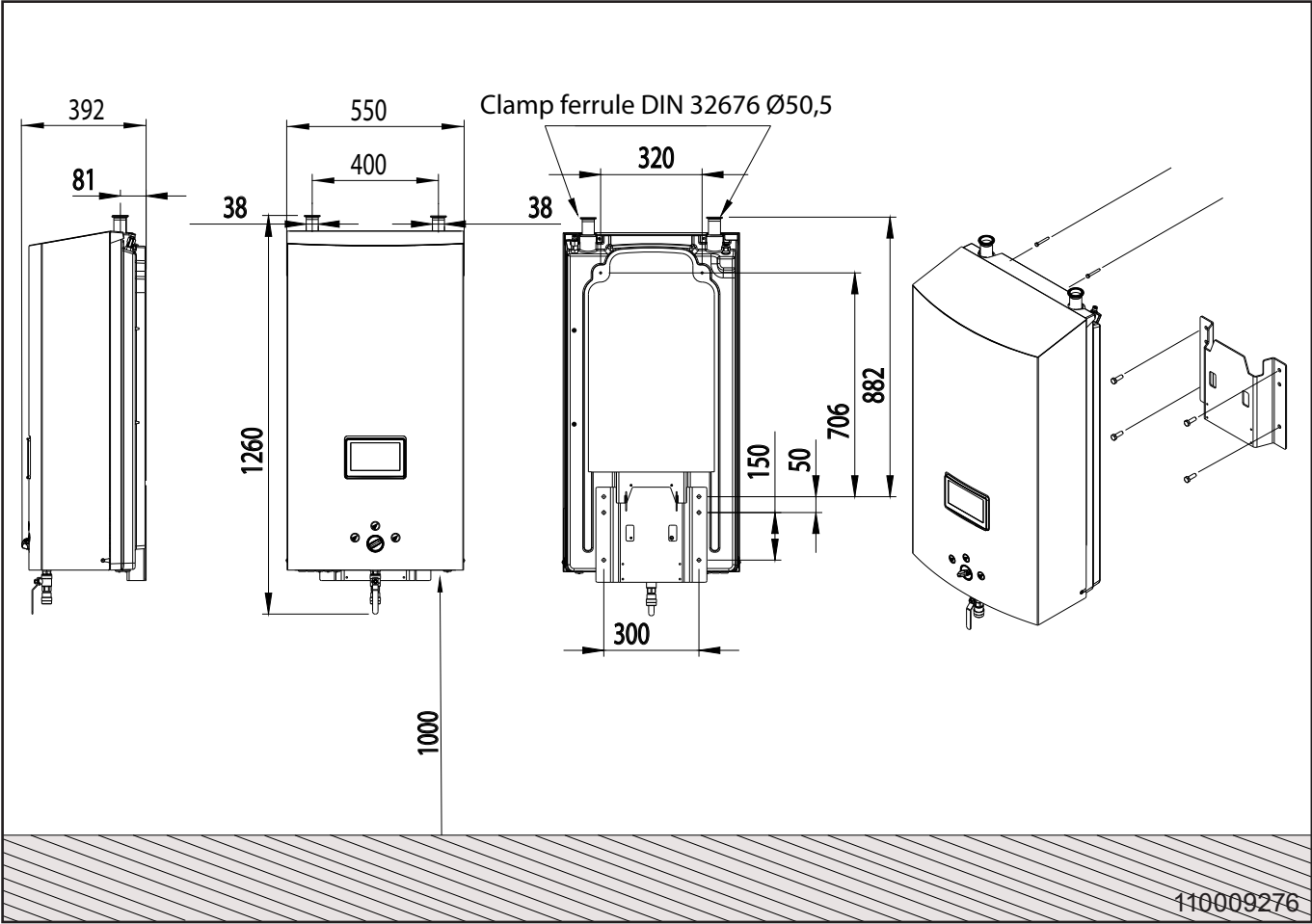

110009276

13.2. Vertical Adjustment MA

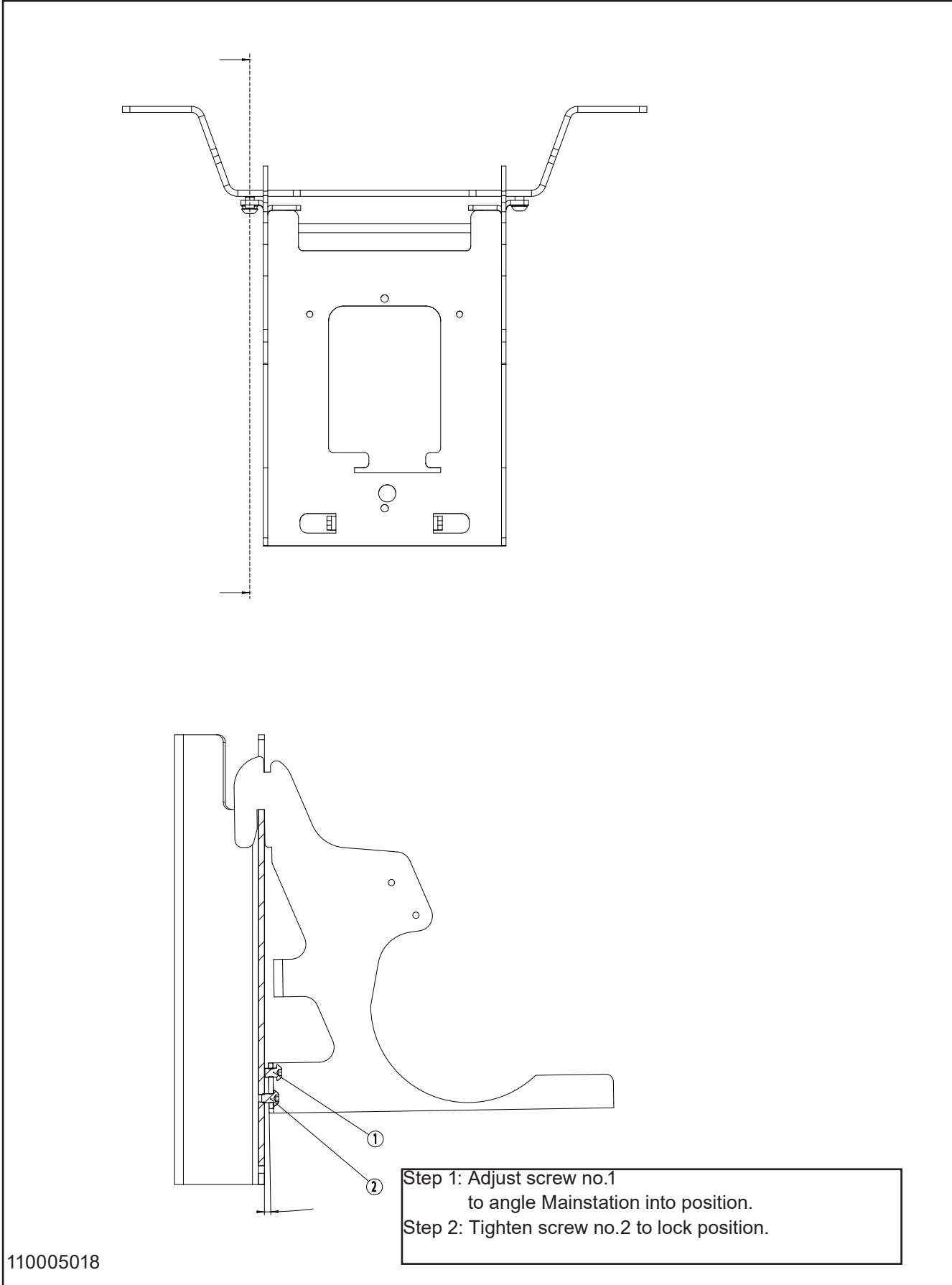

13.3. Installation & mounting SA

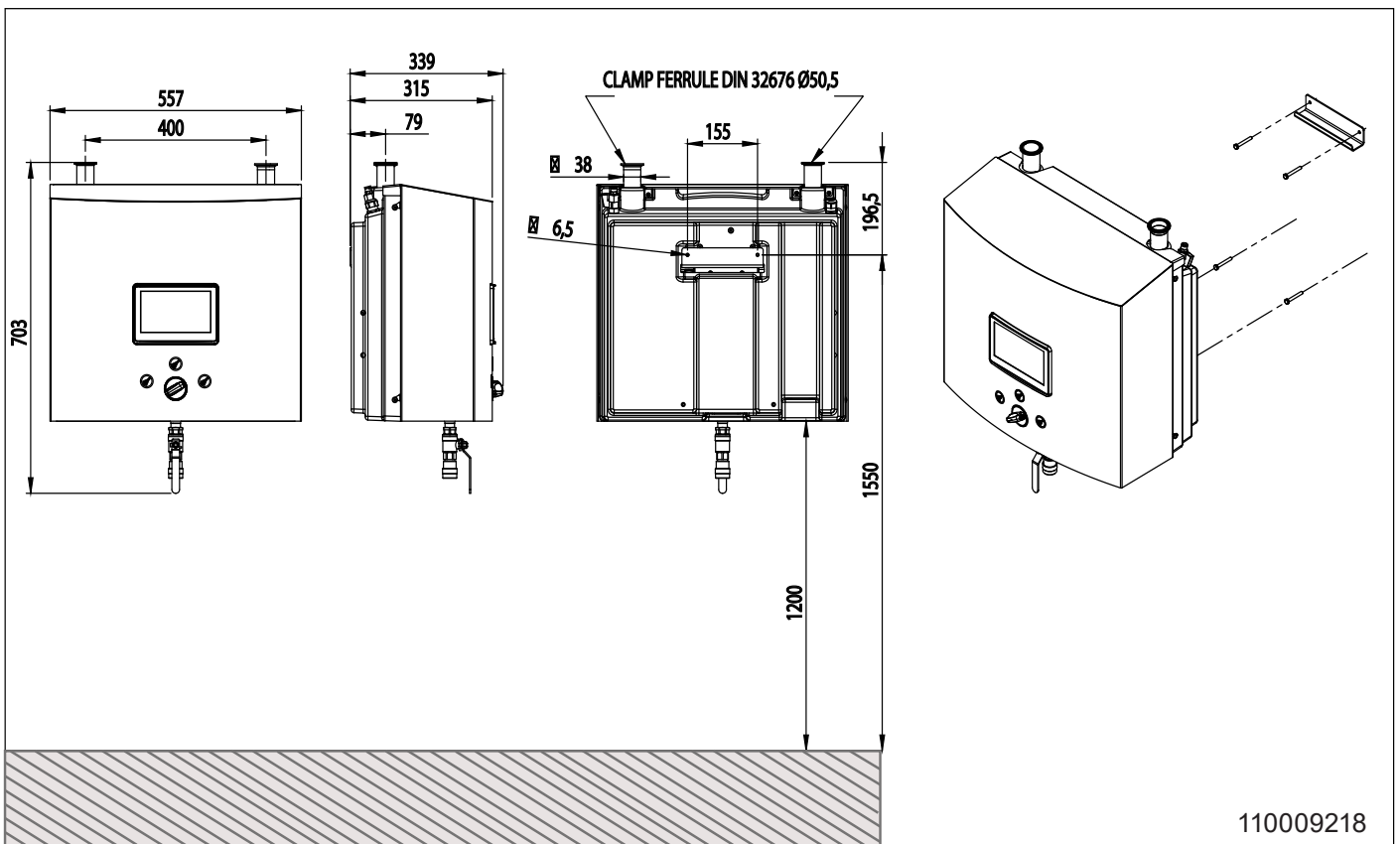
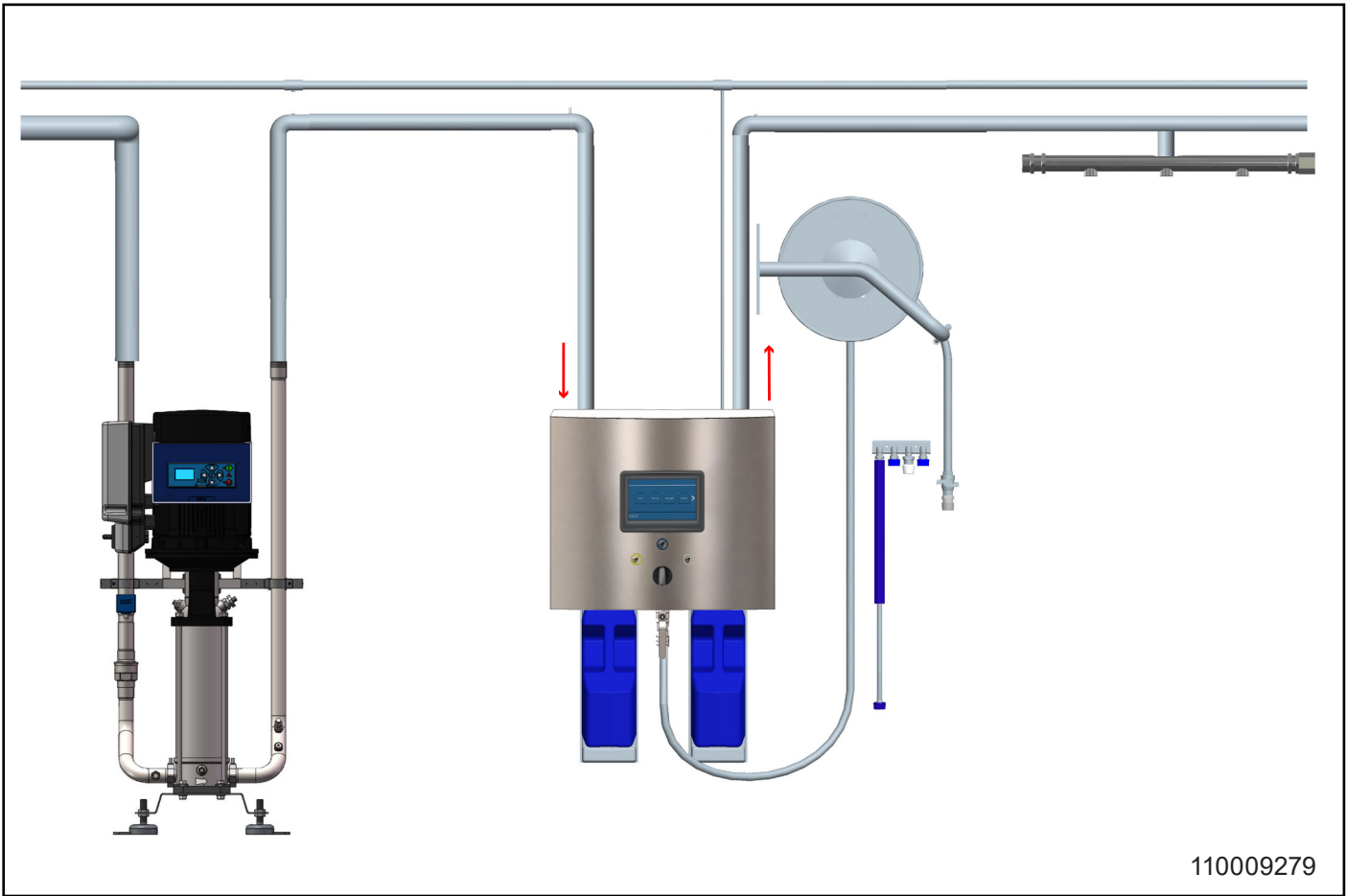

13.4. Layout MA

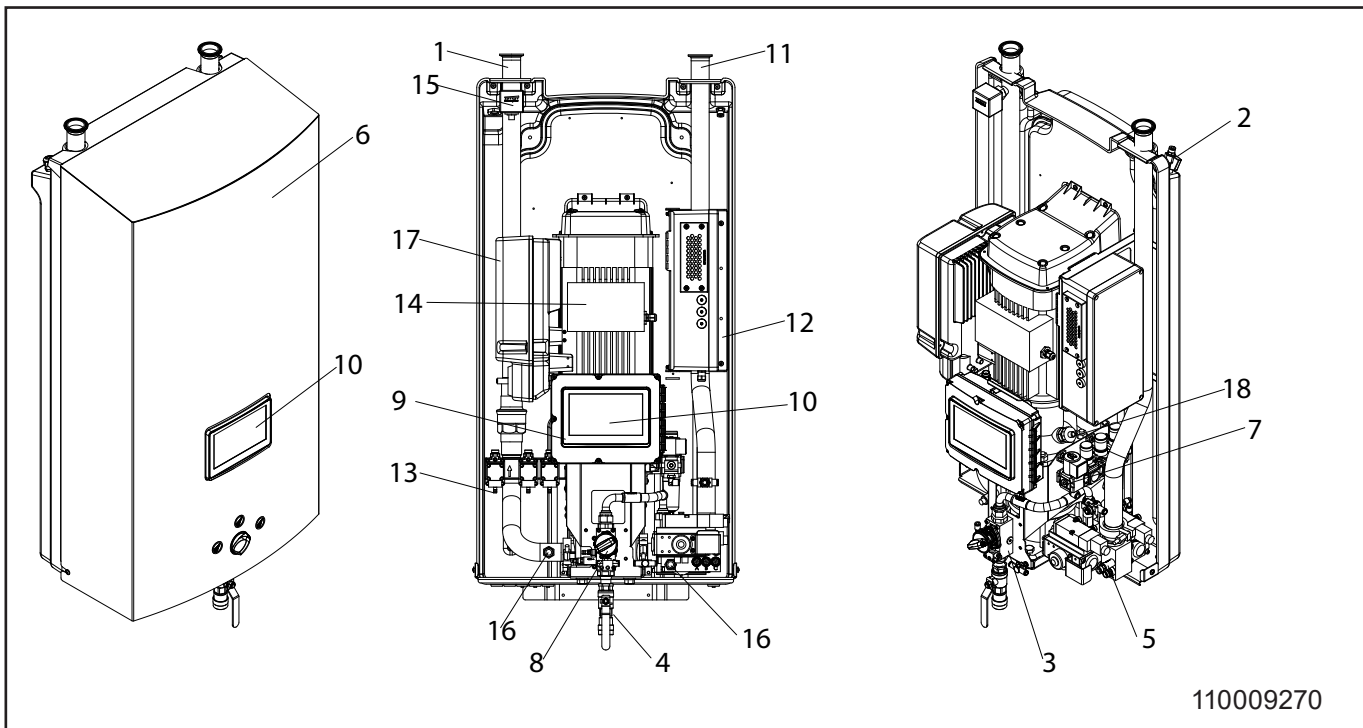

110009270

	English	German	French	Spanish	Italian
1	Water inlet	Wassereinlauf	Entrée d'eau	Entrada de agua	Ingresso dell'acqua
2	Air inlet	Lufteinlass	Entrée d'air	Entrada de aire	Ingresso dell'aria
3	Manual block	Manueller Block	Bloc manuel	Bloque manual	Blocco manuale
4	Ball valve with quick coupling	Kugelventil mit Schnellkupplung	Robinet à boisseau sphérique avec raccord rapide	Válvula de bola con acoplamiento rápido	Valvola a sfera con attacco rapido
5	Automatic block	Automatischer Block	Bloc automatique	Bloque automático	Blocco automatico
6	Cover	Abdeckung	Couverture	Cubrir	Coperchio
7	Air regulator	Luftregler	Régulateur d'air	Regulador de aire	Regolatore dell'aria
8	Operation button	Bedientaste	Bouton de commande	Botón de funcionamiento	Pulsante di funzionamento
9	Multi Controller	Multi Steuerung	Multi contrôleur	Controlador múltiple	Multicontrollore
10	Display	Display	Affichage	Visor	Display
11	Water outlet	Wasserabfluss	Sortie d'eau	Salida de agua	Uscita dell'acqua
12	IO Module	IO Modul	IO Module	IO módulo	IO modulo multi controller
13	Product valves	Produktventile	Vannes de produit	Válvulas de producto	Valvole prodotto
14	Pump	Pumpe	Pompe	Bomba	Pompa
15	Flow switch	Strömungswächter	Interrupteur de débit	Interruotor de flujo	Flussostato
16	Pressure sensor	Druckregler	Capteur de pression	Sensor de presión	Sensore de pressione
17	Inverter	Wandler	Onduleur	Inversor	Inverter
18	Temperature sensor	Temperatur-sensor	Sonde de température	Sonda de temperatura	Sensore di temperatura

13.5. Layout SA

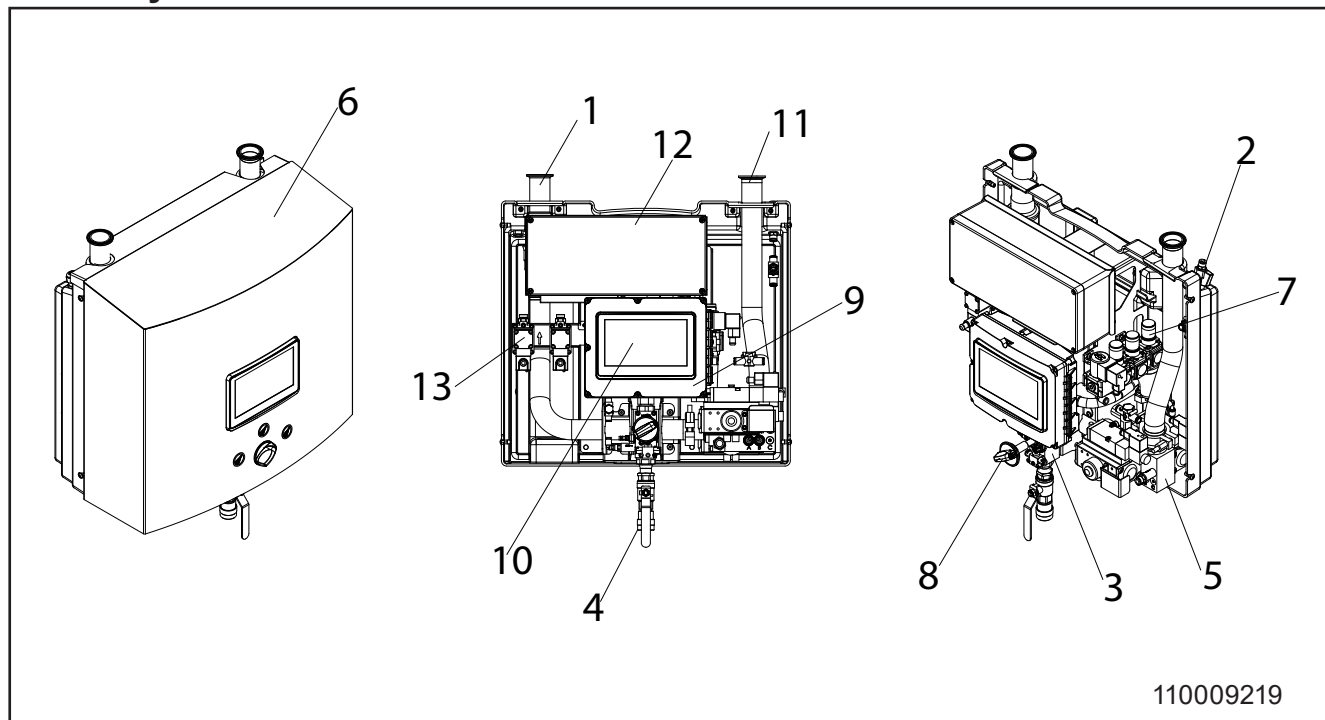

110009219

	English	German	French	Spanish	Italian
1	Water inlet	Wassereinlauf	Entrée d'eau	Entrada de agua	Ingresso dell'acqua
2	Air inlet	Lufteinlass	Entrée d'air	Entrada de aire	Ingresso dell'aria
3	Manual block	Manueller Block	Bloc manuel	Bloque manual	Blocco manuale
4	Ball valve with quick coupling	Kugelventil mit Schnellkupplung	Robinet à boisseau sphérique avec raccord rapide	Válvula de bola con acoplamiento rápido	Valvola a sfera con attacco rapido
5	Automatic block	Automatischer Block	Bloc automatique	Bloque automático	Blocco automatico
6	Cover	Abdeckung	Couverture	Cubrir	Coperchio
7	Air regulator	Luftregler	Régulateur d'air	Regulador de aire	Regolatore dell'aria
8	Operation button	Bedientaste	Bouton de commande	Botón de funcionamiento	Pulsante di funzionamento
9	Multi Controller	Multi Steuerung	Multi contrôleur	Controlador múltiple	Multicontrollore
10	Display	Display	Affichage	Visor	Display
11	Water outlet	Wasserabfluss	Sortie d'eau	Salida de agua	Uscita dell'acqua
12	IO Module	IO Modul	IO Module	IO módulo	IO modulo multi controller
13	Product valves	Produktventile	Vannes de produit	Válvulas de producto	Valvole prodotto

Printed in Denmark

No.: 11009190E 04/2024
Serial no: 204.01.000XXX

© 2014 All rights reserved

ECOLAB Engineering GmbH,
F & B Engineering Competence Centre EMEA,
Raiffeisenstraße 7,
D-83313 Siegsdorf
Telephone.: (+49) 86 62 /61 0 - Fax: (+49) 86 62 / 61 2 35
e-Mail: engineering-mailbox@ecolab.com

ECOLAB®