

Phoenix - Mixing System

MIX08/20 – Inline 20



Content

1.	General	3
1.0	Operation	3
1.1	Warning descriptions	3
1.2	Safety instructions	4
2.	Products	5
2.0	Mounting MIX	5
2.1	Mounting Inline	6
3.	Functional principle	7
3.0	Flow diagram	7
3.1	Electrical diagram MIX	8
3.2	Electrical diagram Inline	11
3.3	Operation diagram MIX	12
4.	Installation	13
4.0	Directions for mounting of the Phoenix	13
4.1	Water connection	13
4.2	Bleeding the pump	14
5.	User Guide	15
5.0	Setting before use	15
5.1	Daily operation	15
5.2	Layout drawing and parts MIX	16
5.3	Layout drawing and parts Inline	18
6.	Technical specifications	19
6.0	Technical data	19
6.1	Identification plate	20
7.	Maintenance	21
7.0	Instructions	21
7.1	Maintenance kits	21
8.	Warranty	23
9.	CE Declaration	24
9.0	CE Declaration of Conformity	24

1. General

The mixing stations are used for mixing and delivery of pre-diluted detergent for cleaning stations or other types of outlets. Water and detergent are mixed by a dosing pump.

It is very important that the operational staff reads this user guide thoroughly prior to installation and start of operation. Operation as laid down in the directions for use will ensure an optimum level of hygiene in your factory and a minimum level of repair work.

1.0 Operation

The Phoenix unit consists of a dosing system – mixing water and chemicals. The MIX solution has a tank where the mixed solution is led into. From this tank the solution is pumped out to the satellites or outlets where the solution is used for cleaning. The Inline solution is without tank and the media is mixed inside the dosing pump and in the pipe work.

For the MIX the liquid level in the tank is adjusted via level sensors placed inside the tank. These sensors send a signal to the controller operating the valve and the dosing pump leading the water into the tank.

These units are made of corrosion resistant material – mainly stainless steel and plastic – and are therefore especially suitable for application within the food industry.

1.1 Warning descriptions

The special warnings **CAUTION**, **ATTENTION**, and **NOTE** used in this User Guide have the following meanings:

CAUTION: This term is used to highlight the fact that complete or even partial failure to properly adhere to operation instructions, working instructions, specified working sequences and similar can cause damage to the equipment.

ATTENTION: This term is used to highlight the fact that complete or even partial failure to properly adhere to operation instructions, working instructions, specified working sequences and similar can cause damage to the equipment.

NOTE: This term is used to draw attention to a particular feature.

1.2 Safety instructions

Repairs must only be carried out when the water supply has been disconnected.

ATTENTION!

Maintenance is only to be carried out by authorized personnel.

2. Products

2.0 Mounting MIX

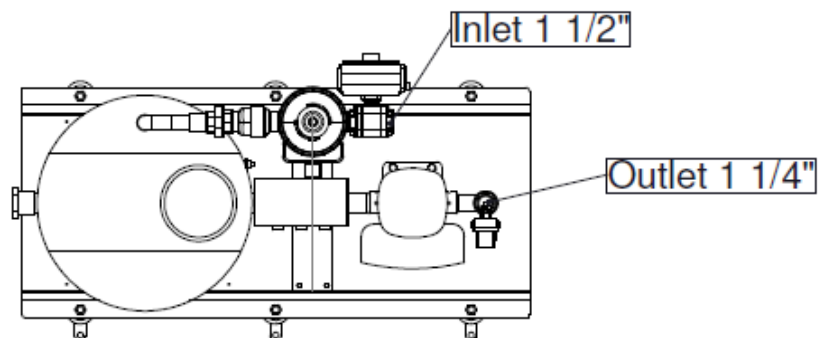
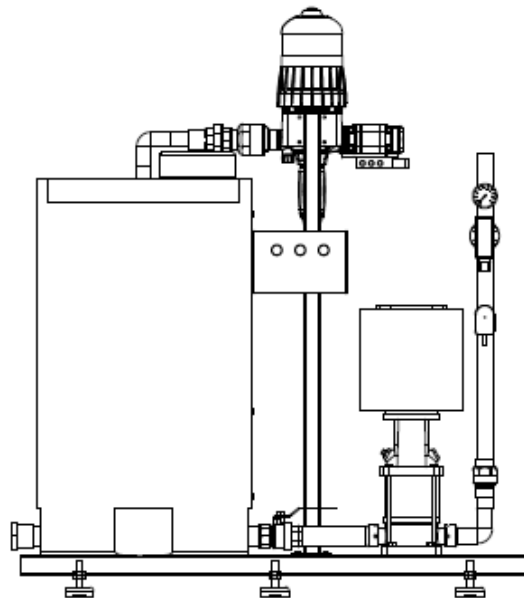

2.1 Mounting Inline

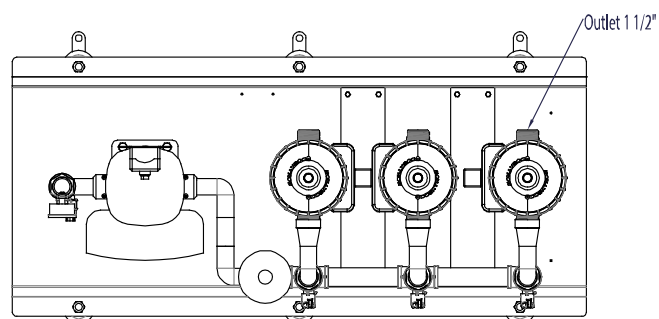
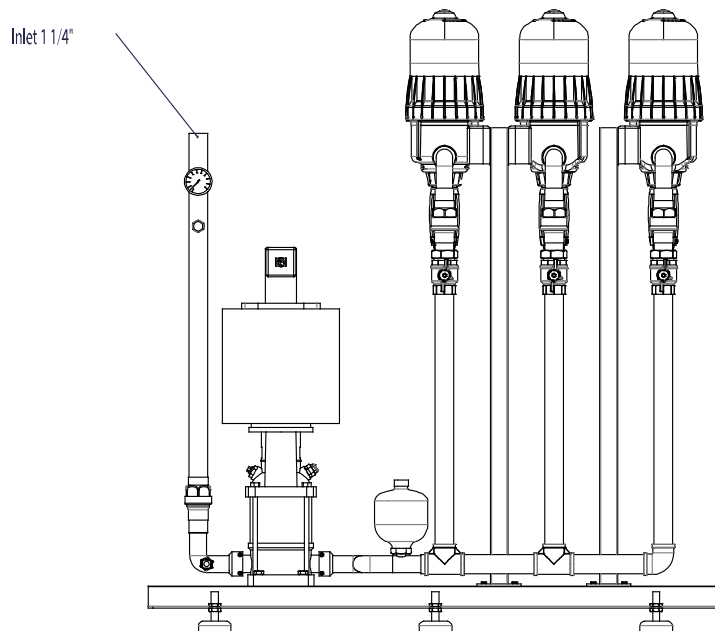

3. Functional principle

3.0 Flow diagram

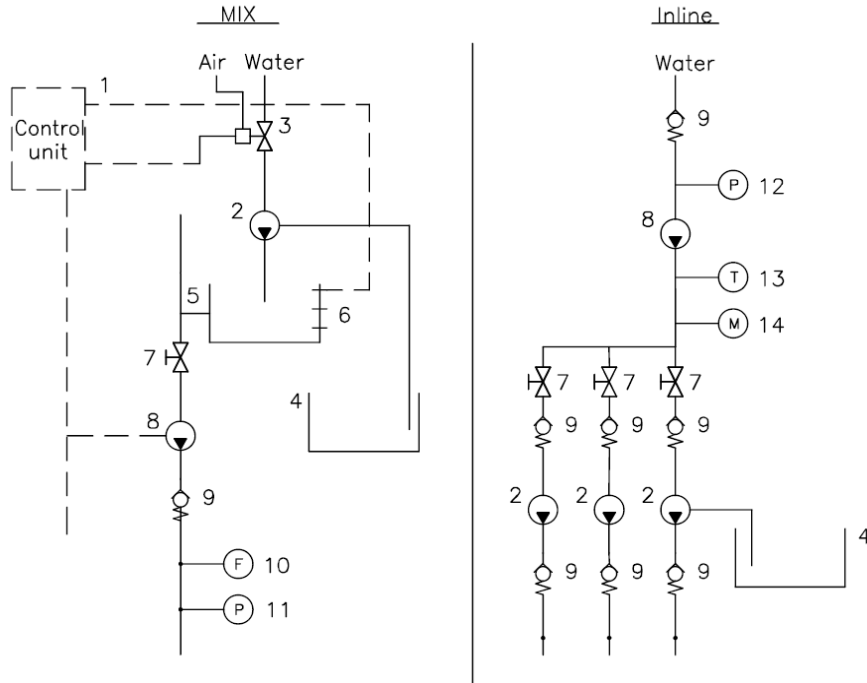

- | | | | |
|---|--------------------------------|----|---------------------------|
| 1 | Controller | 8 | Pump |
| 2 | Dosing pump | 9 | Non return valve |
| 3 | Ball valve w. actuator | 10 | Flow switch |
| 4 | Tank for detergent | 11 | Pressure sensitive switch |
| 5 | Tank for pre-diluted detergent | 12 | Pressure switch |
| 6 | Level sensors | 13 | Pressure transmitter |
| 7 | Ball valve | 14 | Shock absorber |

3.1 Electrical diagram MIX

1	2	3	4	5	6	7	8	9	10	11	12	13	14																																																																																																																																																																																																																								
<table border="1" style="width:100%; border-collapse: collapse;"> <tr> <td style="width:30%;">Customer</td> <td colspan="11">:NILFISK FOOD</td> </tr> <tr> <td>Projekt</td> <td colspan="11">:Eletrical diagram MIX08 – MIX20</td> </tr> <tr> <td>Subject No.</td> <td colspan="11">:</td> </tr> <tr> <td>Case No.</td> <td colspan="11">:1</td> </tr> <tr> <td></td> <td></td> <td></td> <td></td> <td></td> <td></td> <td></td> <td></td> <td style="text-align:center;">MIX 08</td> <td></td> <td></td> <td></td> <td style="text-align:center;">MIX20</td> <td></td> </tr> <tr> <td>Type No.</td> <td colspan="6">: Diagram MIX 08 – MIX 20</td> <td>Rated Voltage</td> <td colspan="2">: 3X380–415V+N+PE</td> <td colspan="4">3x380–415V+N+PE</td> </tr> <tr> <td></td> <td></td> <td></td> <td></td> <td></td> <td></td> <td></td> <td>Rated Frequency</td> <td colspan="2">: 50Hz</td> <td colspan="3">50/60Hz</td> <td></td> </tr> <tr> <td></td> <td></td> <td></td> <td></td> <td></td> <td></td> <td></td> <td>Full-load Current</td> <td colspan="2">: 2,5A</td> <td colspan="3">11 – 8,8A</td> <td></td> </tr> <tr> <td></td> <td></td> <td></td> <td></td> <td></td> <td></td> <td></td> <td>Max Single-load</td> <td colspan="5">:</td> <td></td> </tr> <tr> <td></td> <td></td> <td></td> <td></td> <td></td> <td></td> <td></td> <td>Rated shorttime withstand Current, Icw</td> <td colspan="5">:</td> <td></td> </tr> <tr> <td></td> <td></td> <td></td> <td></td> <td></td> <td></td> <td></td> <td>Max. Fuse</td> <td colspan="2">: 16A</td> <td colspan="3">20A</td> <td></td> </tr> <tr> <td></td> <td></td> <td></td> <td></td> <td></td> <td></td> <td></td> <td>:</td> <td colspan="5"></td> <td></td> </tr> <tr> <td></td> <td></td> <td></td> <td></td> <td></td> <td></td> <td></td> <td>:</td> <td colspan="5"></td> <td></td> </tr> <tr> <td></td> <td></td> <td></td> <td></td> <td></td> <td></td> <td></td> <td>:</td> <td colspan="5"></td> <td></td> </tr> <tr> <td>Projekt Start</td> <td>:</td> <td colspan="6"></td> <td>Highest Pagenumber</td> <td>:</td> <td colspan="4">4</td> </tr> <tr> <td>Change date</td> <td>:</td> <td colspan="6">by (foreshortened):</td> <td>Number of Pages</td> <td>:</td> <td colspan="4">4</td> </tr> </table>														Customer	:NILFISK FOOD											Projekt	:Eletrical diagram MIX08 – MIX20											Subject No.	:											Case No.	:1																			MIX 08				MIX20		Type No.	: Diagram MIX 08 – MIX 20						Rated Voltage	: 3X380–415V+N+PE		3x380–415V+N+PE											Rated Frequency	: 50Hz		50/60Hz											Full-load Current	: 2,5A		11 – 8,8A											Max Single-load	:													Rated shorttime withstand Current, Icw	:													Max. Fuse	: 16A		20A											:														:														:							Projekt Start	:							Highest Pagenumber	:	4				Change date	:	by (foreshortened):						Number of Pages	:	4			
Customer	:NILFISK FOOD																																																																																																																																																																																																																																				
Projekt	:Eletrical diagram MIX08 – MIX20																																																																																																																																																																																																																																				
Subject No.	:																																																																																																																																																																																																																																				
Case No.	:1																																																																																																																																																																																																																																				
								MIX 08				MIX20																																																																																																																																																																																																																									
Type No.	: Diagram MIX 08 – MIX 20						Rated Voltage	: 3X380–415V+N+PE		3x380–415V+N+PE																																																																																																																																																																																																																											
							Rated Frequency	: 50Hz		50/60Hz																																																																																																																																																																																																																											
							Full-load Current	: 2,5A		11 – 8,8A																																																																																																																																																																																																																											
							Max Single-load	:																																																																																																																																																																																																																													
							Rated shorttime withstand Current, Icw	:																																																																																																																																																																																																																													
							Max. Fuse	: 16A		20A																																																																																																																																																																																																																											
							:																																																																																																																																																																																																																														
							:																																																																																																																																																																																																																														
							:																																																																																																																																																																																																																														
Projekt Start	:							Highest Pagenumber	:	4																																																																																																																																																																																																																											
Change date	:	by (foreshortened):						Number of Pages	:	4																																																																																																																																																																																																																											
				ALTO Danmark A/S Bytækkervej 2 Postboks 527 DK-9100 Aalborg Telefon +45 72 18 21 00						Tegnet MBA 13.09.16 Godkendt _____		Tegnings nr. 110002691-1B Erstatning for _____		Revision _____ Ark nr. 1 of 5																																																																																																																																																																																																																							
Mrk.	Dato	Rettelser		Init.		FORSIDE – FRONT PAGE – VORSEITE																																																																																																																																																																																																																															

User Manual - Mixing station

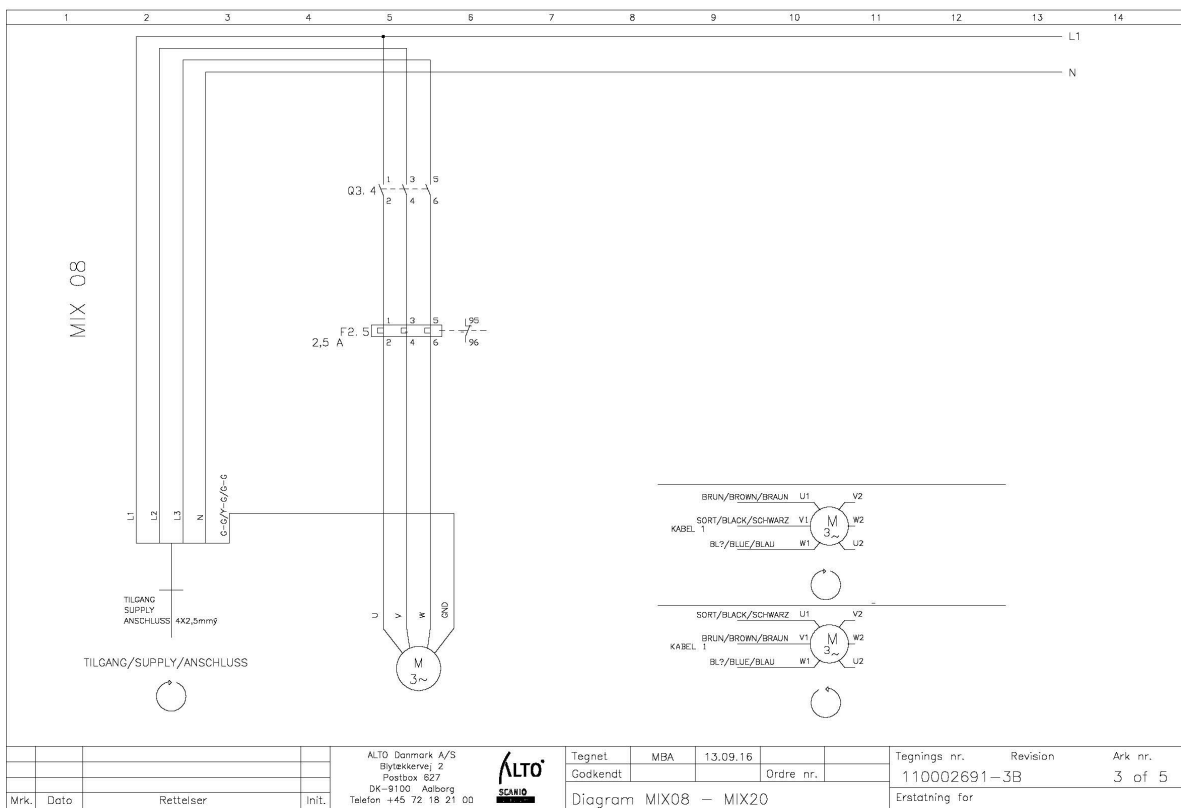
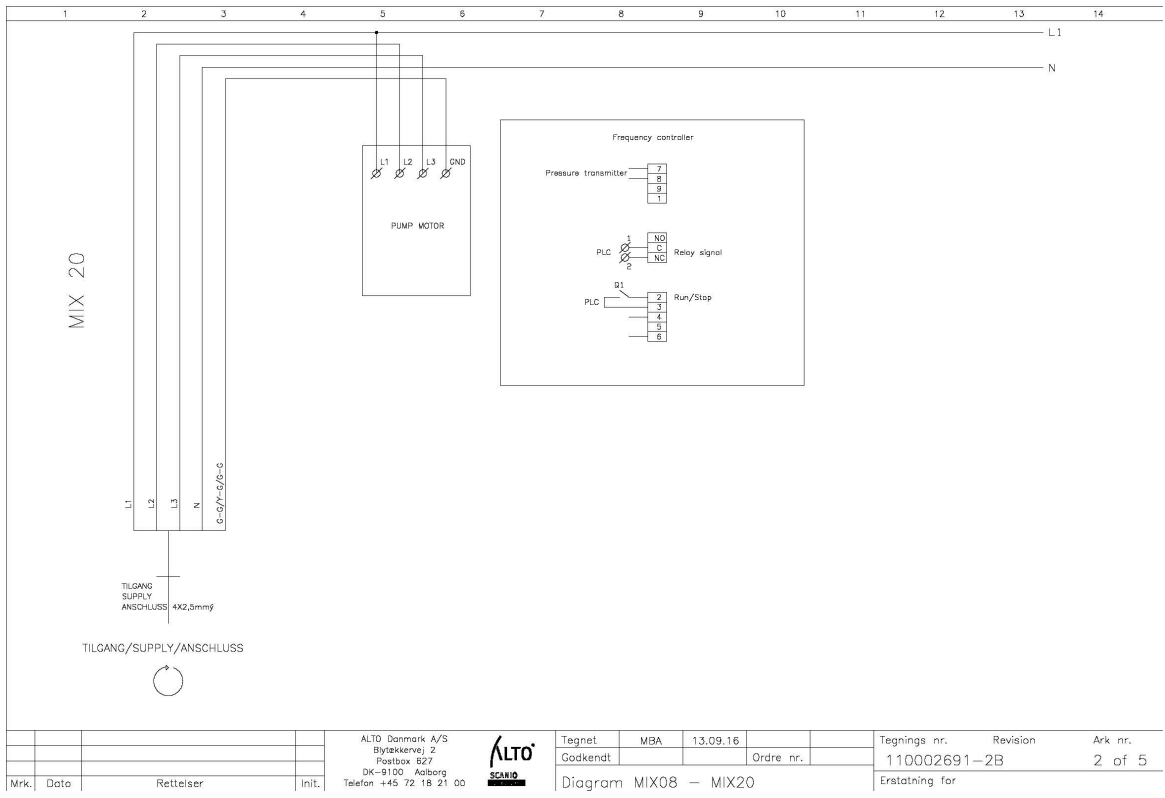

User Manual - Mixing station

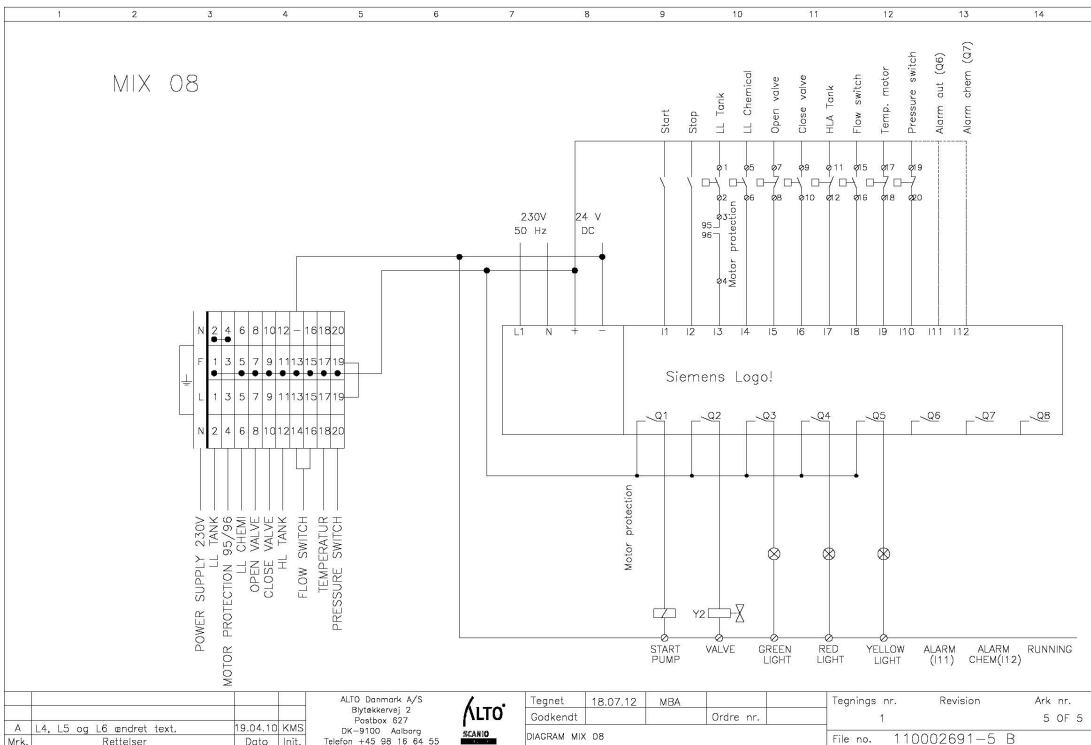
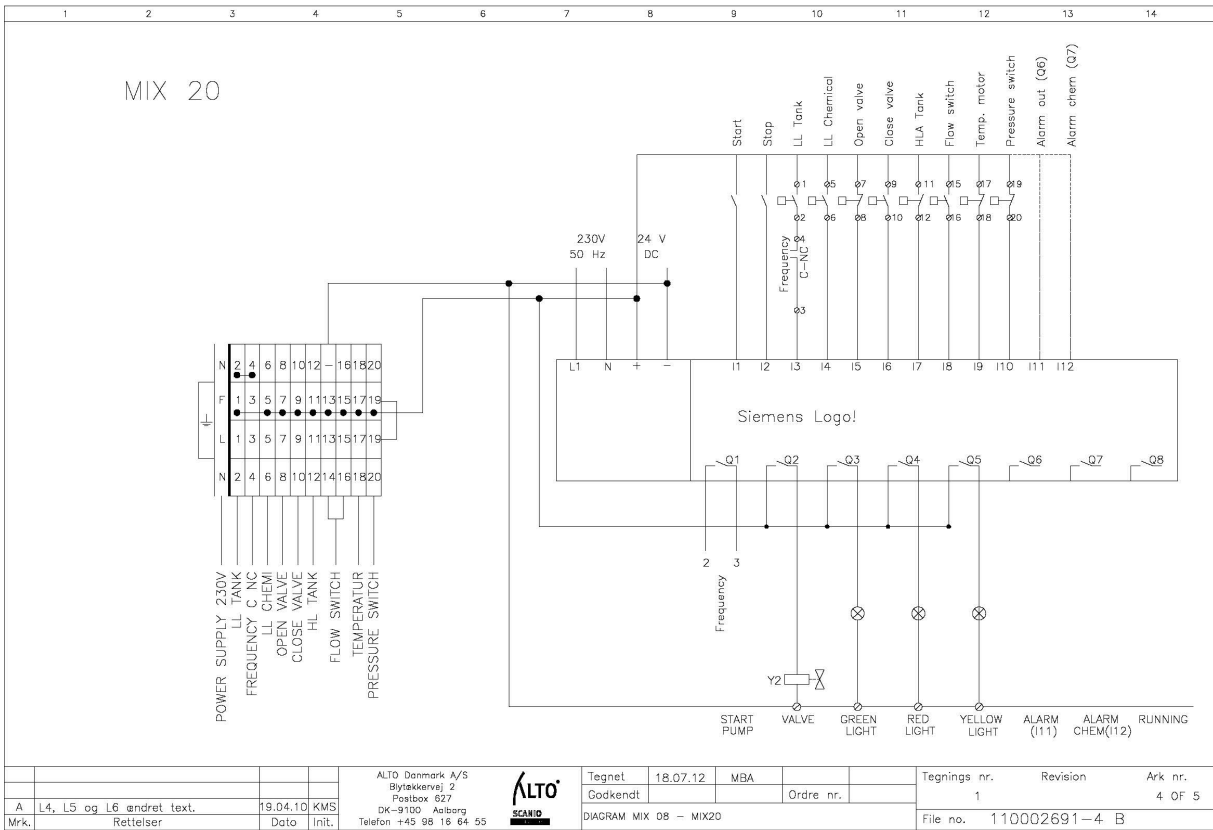

3.2 Electrical diagram Inline

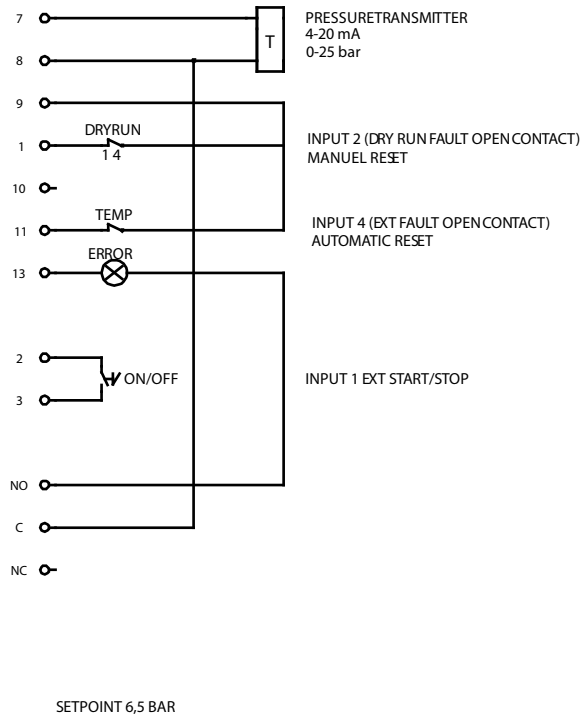
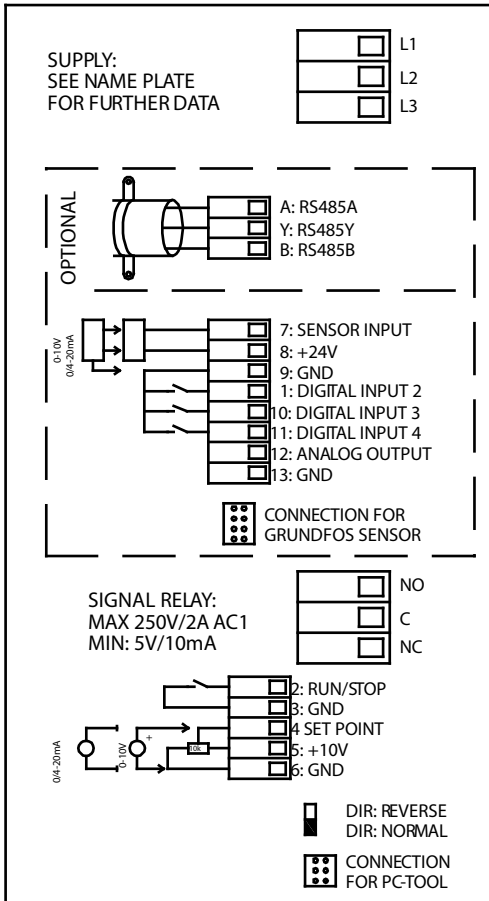

110003804A

3.3 Operation diagram MIX

Input	Function	Action
I 1	Start up unit	Push the green button to start the unit. Green light flashes
I 2	Stop the unit	Unit stops. Red light flashes
I 3	Low level alarm	Switches off the pump and opens valve. Red light flashes fast
I 4	Low level alarm chem.	Closes valve. Yellow light flashes
I 5	Start filling	Opens valve
I 6	Stop filling	Closes valve
I 7	HL alarm	Closes the valve. Red lamp flashes slowly
I 8	Flow switch	Stops the pump by red light postrun for 20 sec.
I 9	Temperature sensor pump top	Stops the pump. Red light flashes slowly
I 10	Pressure start	Starts up the pump (4 bar) (stops after 2 sec. if no flow is detected)
I 11	Alarm output	By alarm, activate Q6
I 12	Alarm chemical output	By alarm, activate Q7
Q1	Start Pump	Start Pump
Q2	Open valve	Open valve
Q3	Operation	Constant lightning when the pump is running. The light flashes in stand by mode
Q4	Alarm	Constant lightning in OFF mode. The light flashes slowly at HLA + temp. Flashes fast at LLA + inverter error
Q5	Chemical alarm	Flashes slowly by lack of chemical
Q6	Alarm	External alarm output
Q7	Chemical alarm	External chemical alarm output
Q8	Operation	External operation output
C-NC	Alarm frequency converter	Stops the pump. Red light flashes fast.

4. Installation

4.0 Directions for mounting of the Phoenix

ATTENTION!

- a) The unit should be mounted in frost free rooms only.
- b) The unit is leveled by adjusting the feet. When the unit is leveled the lock nuts on the feet are to be tightened thoroughly.
- c) The unit is fastened to the floor using a bolt through the hole on each foot. It is sufficient to fasten the feet in the corners.

4.1 Water connection

CAUTION!

- a) **Before the station is connected to the water supply pipe, the supply line should be rinsed carefully in order to remove coarse impurities and metal shavings.**
- b) The pressure loss in the supply line should be held as low as possible by.:
 - avoid long supply pipes
 - mounting of low pressure resistance ball valves and
 - avoiding fittings with high pressure loss

NOTE!

- c) When installing the piping, take care to avoid air traps.
- d)

Max. supply water temperature:	40°C / 104°F
Max. water supply MIX:	120 l/min / 32 US GAL/min
Max. water supply Inline:	240 l/min / 64 US GAL/min
Max. allowed inlet water pressure:	7 bar / 100 psi

4.2 Bleeding the pump

Warning!

Never start up the supply pump before the pump have been bled.

When the unit has been mounted and water has been connected to the inlet side, the pump must be bled. This is done by opening the bleeding screw in the top of the pump. Operate the valve for the dosing pump and fill the tank with water and bled the supply pump. The pump must be bled until only water comes out of the pump.

5. User Guide

5.0 Setting before use

When delivered the unit is pre-set for use. For the MIX this means that the tank will be automatically refilled and that the pump will start up when flow appears in one or more outlets. Further, the pump will stop when the flow ends. Via a signal from a pressure sensitive switch the pumps starts up and stops running via a signal from a flow switch. The pressure sensitive switch is pre-set by the supplier. The flow switch might have to be fine tuned. The adjustment of the flow switch is carried out as follows: open up one outlet, adjust the flow switch screw until one yellow diode and one green diode lights up. This must correspond the min. achievable consumption.

The Inline units is stop and started by a pressure transmitter. All the controlling is done by the frequency inverter and the parameters listed together with the diagram.

Concentration of detergent is to be adjusted directly on the inlet of the dosing pump. For further data and service on the dosing pump please see data sheet and manual for the dosing pump.

5.1 Daily operation

When adjusted according to the above descriptions the unit runs automatically. This means that the tank automatically is refilled and that the pump, during flow in one or more outlets, is in operation.

Before using the outlet always connect a disinfection nozzle or foam nozzle to the pistol/closing valve.

Only seconds after opening of the pistol/low pressure valve the pump starts up and a working pressure automatically appears.

WARNING!

We recommend only using original nozzles at the outlets.

5.2 Layout drawing and parts MIX

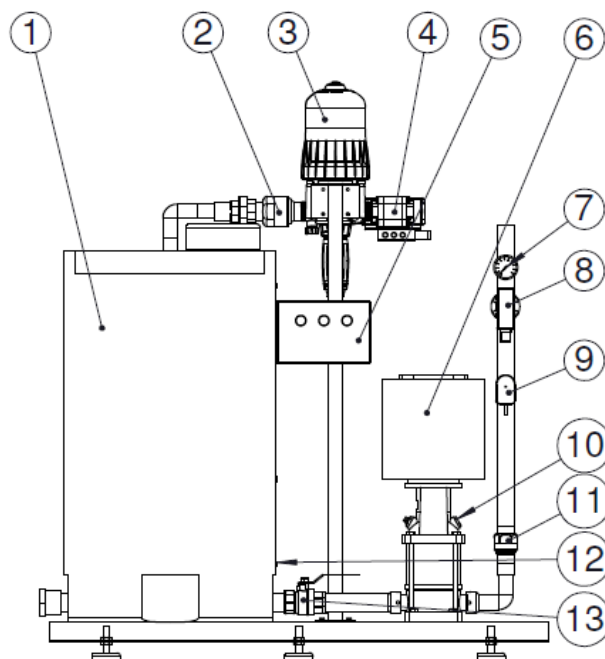

⇒ 04 - 2013

Pos. no.	Item no.	Description	Amount
1	0636050	Polyethylen tank 200 L	1
2	110002418	Non-return valve 1 ½"	1
3	110002665	Dosatron pump VF sealing	1
	110002401	Dosatron pump AF sealing	1
4	0603102	Ball valve 1 ½" with actuator	1
5	110002718	Controller Mix station	1
	110002979	PLC with program	1
	110002720	I/O modul	1
	110002721	Transformer	1
6	110002980	Pump CRNE 5-6 with program	1
	0601646	Pump CRN 3-15	1
7	0639092	Manometer	1
8	110000804	Pressure switch 0,5-10 bar	1
9	0633003	Flow switch	1
10	313000	Pressure transmitter 0-25 bar	1
11	110002403	Non-return valve 1 ¼"	1
12	313600	Level sensor	4
13	359988	Ball valve 1 1/2"	1

04-2013 ⇨

Pos. no.	Item no.	Description	Amount
1	0636050	Polyethylen tank 200 L	1
2			
3	110002665	Dosatron pump VF sealing 1-5%	1
	110002401	Dosatron pump AF sealing 1-5%	1
	110003657	Dosatron pump VF sealing 0,2-2%	1
	110003647	Dosatron pump AF sealing 0,2-2%	1
4	0603102	Ball valve 1 ½" with actuator	1
5	110002718	Controller Mix station	1
	110002979	PLC with program	1
	110002720	I/O modul	1
	110002721	Transformer	1
6	110002980	Pump CRNE 5-6 with program	1
	0601646	Pump CRN 3-15	1
7	110002978	Manometer	1
8	110000804	Pressure switch 0,5-10 bar	1
9	110000973	Flow switch ¼"	1
10	313000	Pressure transmitter 0-25 bar	1
11	110002403	Non-return valve 1 ¼"	1
12	313600	Level sensor	4
13	359988	Ball valve 1 1/2"	1

5.3 Layout drawing and parts Inline

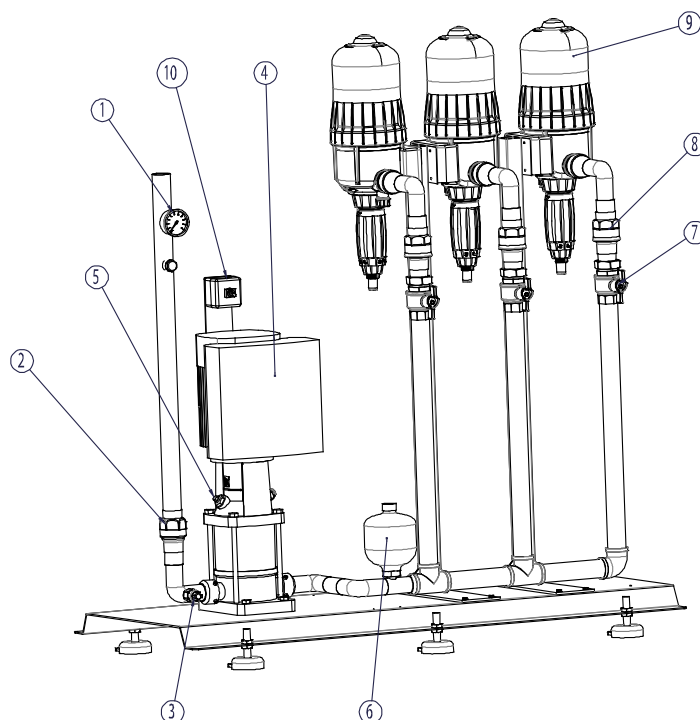

Pos. no.	Item no.	Description	Amount
1	659000	Manometer 0-60 bar	1
2	630900	Non-return valve 1 ¼"	1
3	0631030	Pressure switch 0,5 bar	1
4	110003806	Pump CRNE 5-6 with program	1
5	313000	Pressure transmitter 0-25 bar	1
6	631700	Shock reduction tank	1
7	0603205	Ball valve with union 1 ¼"	1-3
8	110002418	Non-return valve 1 ½"	3-6
9	110002665	Dosatron pump VF sealing 1-5%	1-3
	110002401	Dosatron pump AF sealing 1-5%	1-3
	110003657	Dosatron pump VF sealing 0,2-2%	1-3
	110003647	Dosatron pump AF sealing 0,2-2%	1-3
10	110000633	ON / OFF contact	1

6. Technical specifications

6.0 Technical data

	Data		
	MIX08	MIX20	Inline 1/2/3
Max. operational pressure	7 bar	7 bar	7 bar'
Water flow inlet	50 l/min	140 l/min	240 l/min
Water flow outlet	50 l/min	140 l/min	120 l/min pr unit
Max. temperature for water	40°C	40°C	40°C
Recommended disinfection spray nozzle	30 l/min	30 l/min	30 l/min
Recommended foam nozzle	200 l/min	200 l/min	200 l/min
Max. hose length per outlet	30 m	30 m	30 m
Weight	75 kg	100 kg	70/80/90 kg
Dimension WxHxD	1300x1500x600	1300x1500x600	1300x1500x600

6.1 Identification plate

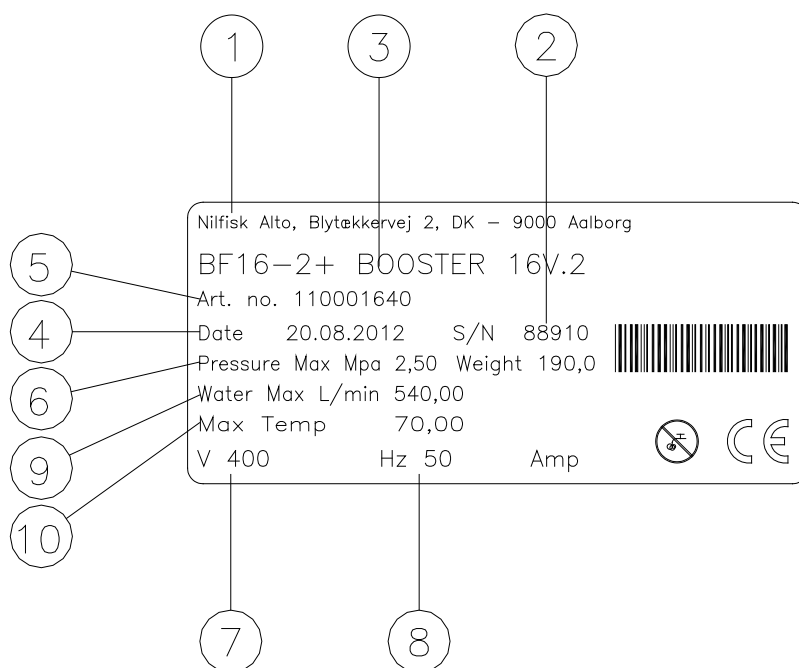

17194

- 1. Producer
- 2. Serial number
- 3. Type
- 4. Date
- 5. Article number
- 6. Max. pressure
- 7. Power supply
- 8. Frequency
- 9. Max. flow
- 10. Max temperature

7. Maintenance

7.0 Instructions

- a) After one month of use the Phoenix station must be maintained by a service engineer. The functionality and any possible errors should be maintained. Furthermore, the unit must be checked for leaks.

The above maintenance should be carried out minimum every third month. If required the interval might be shorter.

- b) Depending on usage, at least once a year maintenance should be undertaken by an authorized service engineer in order to prevent defects and failure of operation. Authorized engineers are persons who due to their skills and experience have sufficient knowledge of the unit in question and are confident with the state work safety regulations, accident preventing regulations, lines and generally acknowledged technical regulations such as DIN-norms and VDE provisions. For your safety this cleaning unit has been manufactured according to all relevant regulations valid in the EU and it has therefore been fitted with the CE marking.

7.1 Maintenance kits

The dosing pumps have some moving parts and in the combination with different detergents these parts have to be changed during time and use. It is recommended to make service at these pumps due to working conditions to keep these in function. O-ring in motor part and or in dosing part should be changed during service. There is for these pumps one o-ring kit for the motor part and two kits for the dosing part – depending on the detergent – AF or VF material.

Item no.	Description	Parts
110003617	Service kit dosing part AF	4
110003618	Service kit dosing part VF	4
110003619	O-ring kit motor part	3

Service kit dosing 110003617 and 110003618

3 x o-rings JDI123, JDI122 and JDI100
 1 x non-return valve PJDI118

O-ring kit motor part 110003619

1 x o-ring 8J041
 2 x o-rings 20J002

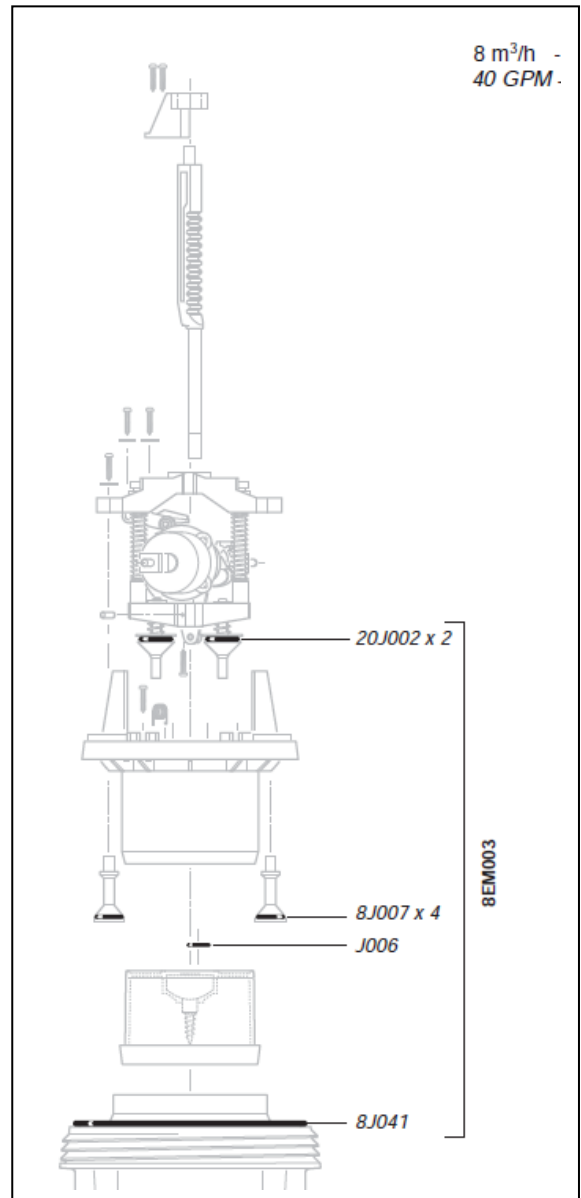
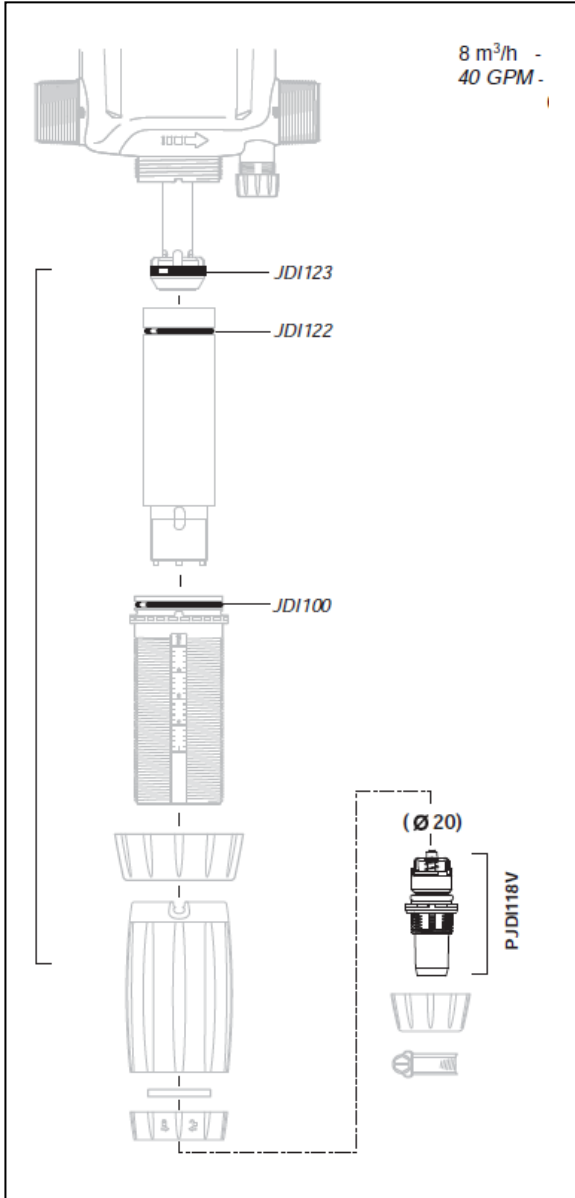

8. Warranty

ATTENTION!

Our guarantee is given for a period of 12 months from delivery on all parts which have provable become unfit for use due to material, construction or manufacturing defects as well as inadequate work. The guarantee compensation will occur in the shape of reimbursement, replacement or repair of the defective or damaged part at our works. Installation and freight costs are always on the purchaser's account. Any defective parts are to be placed at our disposal. Claims that may otherwise be raised for any legal reason will not be acknowledged. No liability will be accepted for damage occurred indirectly. The purchaser has no right to let any third party repair possible defects on our account.

All hoses, rubber parts or synthetic materials natural wear and tear as well as damage caused by careless and inappropriate handling, including transport damage are not covered by the guarantee. Further, the guarantee does not apply if the system has been subjected to frost. The obligation of guarantee compensation also ceases if changes or repairs are made by non-authorized persons. Claims under the guarantee will only be acknowledged when they are placed immediately after the defect has been noticed. The guarantee ceases in case of change of ownership.

The dealer cannot be held responsible for personal injury, damage to equipment, working deficits, including production loss, loss of profits, loss of stock or the like which may occur by imperfect and delayed delivery of the sold product, regardless of the reason, including manufacturing and material defects. Please see our standard terms of sale and delivery.

9. CE Declaration

9.0 CE Declaration of Conformity

Nilfisk Food declares that the machine:

No.: 119000180, 119000181, 119000181, 119000182, 119000261, 119000262,
119000263, 119000264, 119000265, 119000266

Name: Phoenix MIX and Inline
Type: Mixing station

- is manufactured in conformity with the following standards:

Directive 2006/42/CE of the European Parliament and of the Council of 22 June 1998 on the approximation of the laws of the Member States relating to machinery.

EN 60335-2-79 Household and similar electrical appliances – Safety
Particular requirements for high pressure cleaners and steam cleaners
EN 60335-2-34 Household and similar electrical appliances – Safety
Particular requirements for motor-compressors

Council Directive 2004/108/CE of 3 May 1989 on the approximation of the laws of the Member States relating to Electromagnetic Compatibility.

EN 55014-1 Electromagnetic compatibility
EN 55014-2 Electromagnetic compatibility
EN 61000-2-3 Electromagnetic compatibility
EN 61000-3-3 Electromagnetic compatibility

Aalborg d. 02.06.2014

Signature:



Michael Mortensen
Manager OEM and Special

110004167