

110002002

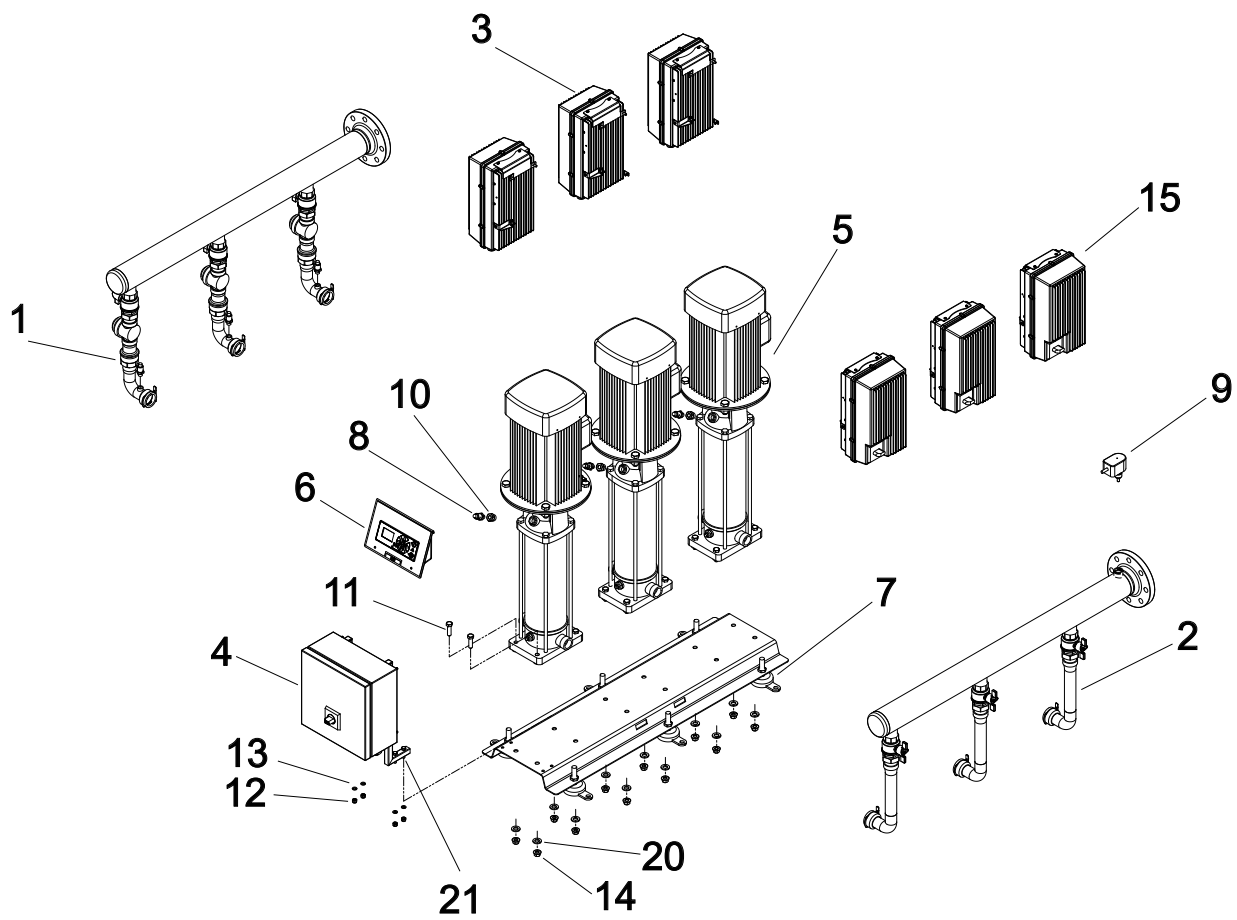

1100001830

Pos./Ref.	Nr. No.	Description Beschreibung Couvercle, unité principale Descripción Betegnelse	BF16 / BF16T	BF24 / BF24T	BF32 / BF32T	BF40 / BF40T	BF48 / BF48T
1		Page 4 Seite 4 Page 4 Página 4 Side 4					
2		Page 4 Seite 4 Page 4 Página 4 Side 4					
3		Page 8 / 9 Seite 8 / 9 Page 8 / 9 Página 8 / 9 Side 8 / 9					
4		Page 6 / 7 Seite 6 / 7 Page 6 / 7 Página 6 / 7 Side 6 / 7					
5	110000373	Pump Pumpe Pompe Bomba Pumpe	2	3	4	5	6
6		Page 5 Seite 5 Page 5 Página 5 Side 5					
7	110001855	Adjustable feet Maschinenfüsse Pieds réglables Pies ajustables Maskinsko	4	6	8	10	12
8	110001144	Pressure Sensor Druck-sensor Sonde de depression Sensor de la presión Tryksensor	2	3	4	5	6
9	110001851	Flow-Switch Strömungswächte Limiteur de débit Interruptor de flujo Flowswitch	1	1	1	1	1
10	110001271	Nippel Nippelrohr Mamelon Entrerosca Nippelmuffe	2	3	4	5	6
11	110001842 (156704)	Screw kit for MB+ Schrauben kitt für MB+ Kit de vis pour MB+ Kit de tornillos MB+ Skrue kit for MB+					
12	110001842 (156518)	Screw kit for MB+ (No tank control) Schrauben kitt für MB+ (Ohne Tanksteuerung) Kit de vis pour MB+ (Pas de contrôle du réservoir) Kit de tornillos MB+ (No hay control del tanque) Skrue kit for MB+ (Uden tankstyring)	1	1	-	-	-
12	110001842 (156502)	Screw kit for MB+ (No tank control) Schrauben kitt für MB+ (Ohne Tanksteuerung) Kit de vis pour MB+ (Pas de contrôle du réservoir) Kit de tornillos MB+ (No hay control del tanque) Skrue kit for MB+ (Uden tankstyring)	1	1	-	-	-
14	110001842 (321700)	Screw kit for MB+ Schrauben kitt für MB+ Kit de vis pour MB+ Kit de tornillos MB+ Skrue kit for MB+					
15		Page 6 / 7 Seite 6 / 7 Page 6 / 7 Página 6 / 7 Side 6 / 7					
16	110001863	Non Return Valve Rückschlagventil Valve non de retour Válvula no de vuelta Kontraventil	-	-	1	1	1
17	110001842 (156800)	Screw kit for MB+ Schrauben kitt für MB+ Kit de vis pour MB+ Kit de tornillos MB+ Skrue kit for MB+					
18	110001842 (0602005)	Screw kit for MB+ Schrauben kitt für MB+ Kit de vis pour MB+ Kit de tornillos MB+ Skrue kit for MB+					
19	110001842 (0602014)	Screw kit for MB+ Schrauben kitt für MB+ Kit de vis pour MB+ Kit de tornillos MB+ Skrue kit for MB+					
20	110001842 (156702)	Screw kit for MB+ Schrauben kitt für MB+ Kit de vis pour MB+ Kit de tornillos MB+ Skrue kit for MB+					

Pos./Ref.	Nr. No.	Description Beschreibung Couvercle, unité principale Descripción Betegnelse	BF16 / BF16T	BF24 / BF24T	BF32 / BF32T	BF40 / BF40T	BF48 / BF48T
21	110001842 (156504)	Screw kit for MB+ (No tank control) Schrauben kitt für MB+ (Ohne Tanksteuerung) Kit de vis pour MB+ (Pas de contrôle du réservoir) Kit de tornillos MB+ (No hay control del tanque) Skrue kit for MB+ (Uden tankstyring)	1	1	-	-	-
12	110001842 (0602057)	Screw kit for MB+ Schrauben kitt für MB+ Kit de vis pour MB+ Kit de tornillos MB+ Skrue kit for MB+	1	1	1	1	1
13	110001842 (156602)	Screw kit for MB+ Schrauben kitt für MB+ Kit de vis pour MB+ Kit de tornillos MB+ Skrue kit for MB+	1	1	1	1	1
21	110001842 (156607)	Screw kit for MB+ Schrauben kitt für MB+ Kit de vis pour MB+ Kit de tornillos MB+ Skrue kit for MB+	1	1	1	1	1

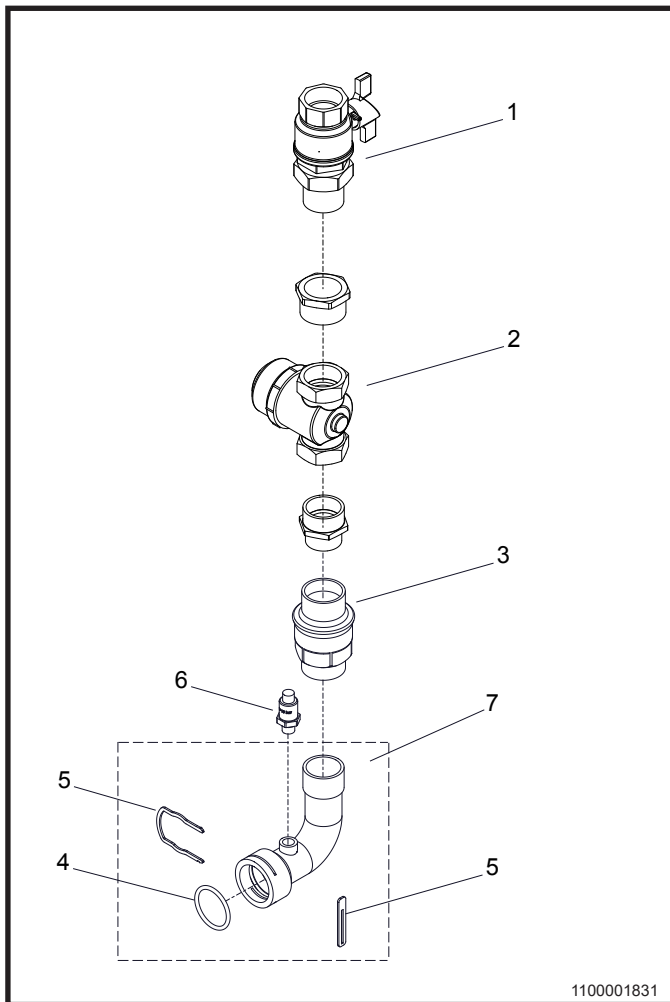

1100001831

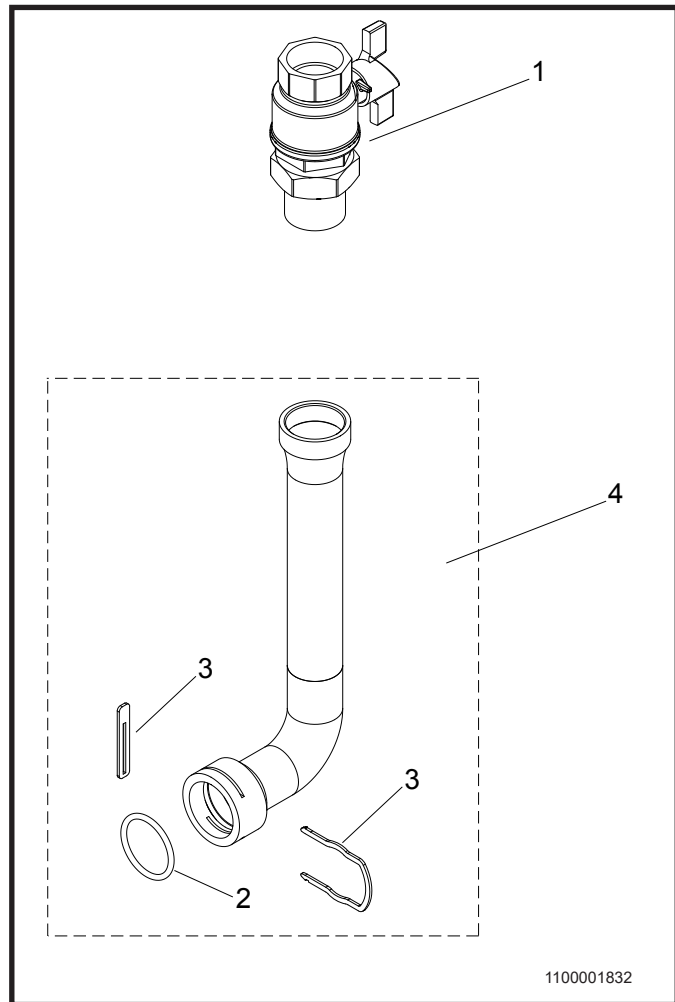

1100001832

!	Nr. No.	Description Beschreibung Couvercle, unité principale Descripción Betegnelse	BF16 / BF16T	BF24 / BF24T	BF32 / BF32T	BF40 / BF40T	BF48 / BF48T
1	110001846	Ball Tap Kugelhahn Robinet à bille Tapón esférico Kuglehane	2	3	4	5	6
2	110002172	Strainer 800µ -> 1500µ Filter 800µ -> 1500µ Tamis 800µ -> 1500µ Tamiz 800µ -> 1500µ Snavssamler 800µ -> 1500µ	2	3	4	5	6
3	630900	Non Return Valve Rückschlagventil Valve non de retour Válvula no de vuelta Kontraventil	2	3	4	5	6
4	110001845	O-ring kit O-ring Set Kit de joints toriques Kit de anillos tóricos O-rings kit					
5	110001250	Pin kit Splint-kitt Kit des broches Kit de pasadores Splint kit					
6	110001850	Sensor Sensor Sondet Sensor sensor	2	3	4	5	6
7	110001848	Inlet Lufteinlauf Admission Entrada de aire Tilgangsør	2	3	4	5	6

!	Nr. No.	Description Beschreibung Couvercle, unité principale Descripción Betegnelse	BF16 / BF16T	BF24 / BF24T	BF32 / BF32T	BF40 / BF40T	BF48 / BF48T
1	110001846	Ball Tap Kugelhahn Robinet à bille Tapón esférico Kuglehane	2	3	4	5	6
2	110001845	O-ring kit O-ring Set Kit de joints toriques Kit de anillos tóricos O-rings kit					
3	110001250	Pin kit Splint-kitt Kit des broches Kit de pasadores Splint kit					
4	110001856	Outlet pipe MB+ complett Abgangsrohr MB+ Komplett Conduit de sorti MB+ complet Tubería de salida MB+ completa Afgangsør MB+ komplet	2	3	4	5	6

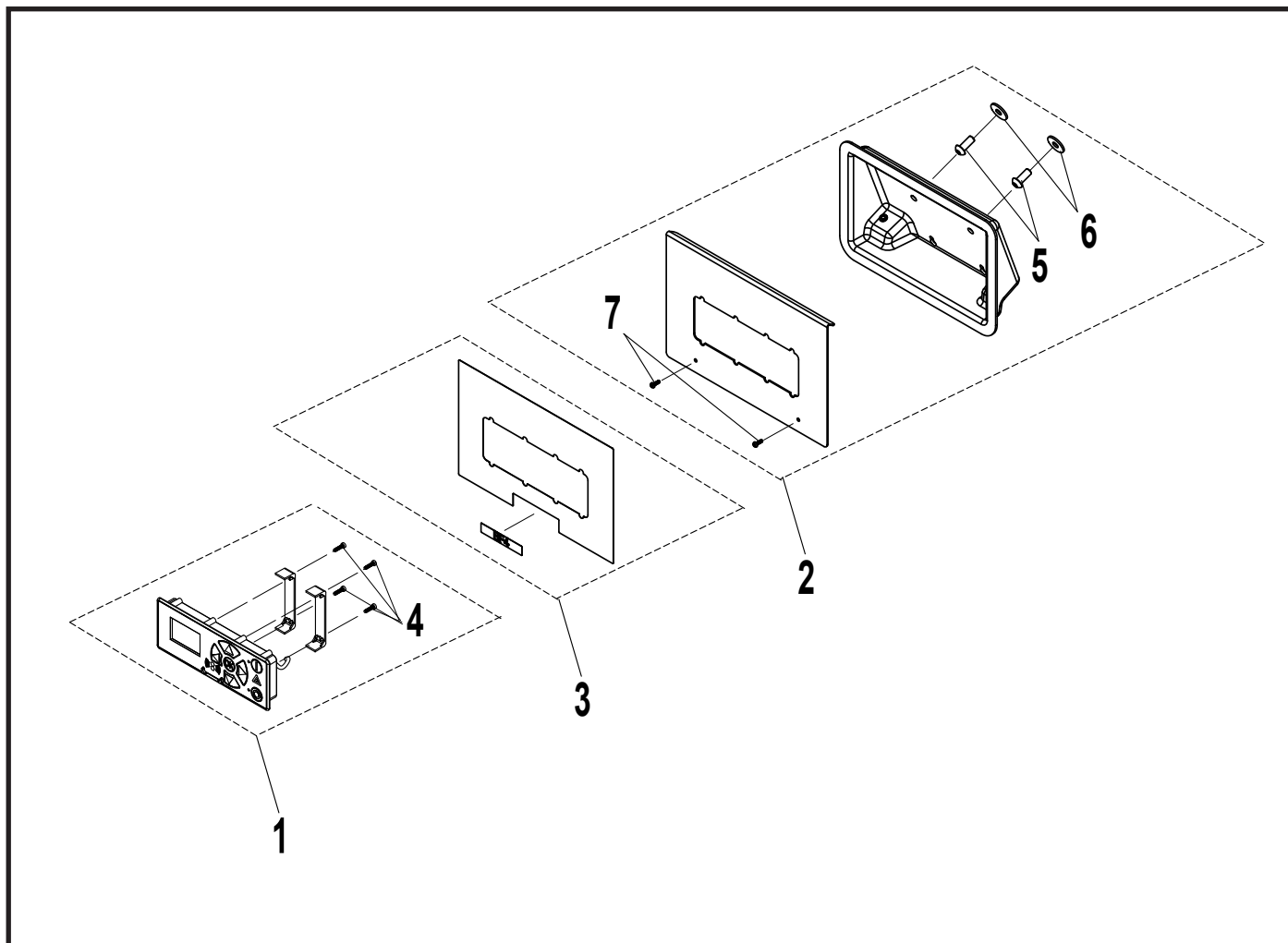

Pos./Ref.	Nr. No.	Description Beschreibung Couvercle, unité principale Descripción Betegnelse					
			BF16	BF24	BF32	BF40	BF48
1	110001841	Display complete Display komplett Afficheur complet Pantalla completa Display kpl.	1	1	1	1	1
2	110001470	Operation panel Bedienungspaneel Panneau d'opération Panel de la operación Betjeningspanel	1	1	-	-	-
3	110001854	Label kit MB+ Aufkleber Kitt MB+ Etiquette MB+ Etiqueta MB+ Label kit MB+	1	1	-	-	-
▲	110001842 (110000574)	Screw kit Adv+ Schraube Set Adv+ Kit de Vis Adv+ Kit de Tornillos Adv+ Skruer kit Adv+					
▲	110001842 (0602072)	Screw kit Adv+ Schraube Set Adv+ Kit de Vis Adv+ Kit de Tornillos Adv+ Skruer kit Adv+					
▲	110001842 (156517)	Screw kit Adv+ Schraube Set Adv+ Kit de Vis Adv+ Kit de Tornillos Adv+ Skruer kit Adv+					
▲	110001842 (110000235)	Screw kit Adv+ Schraube Set Adv+ Kit de Vis Adv+ Kit de Tornillos Adv+ Skruer kit Adv+					

Pos./Ref.	Nr. No.	Description Beschreibung Couvercle, unité principale Descripción Betegnelse					
			BF16	BF24	BF32	BF40	BF48

* Recommended spare parts / Empfehlenswerte Ersatzteile / Pièces de rechange conseillées / Piezas de repuesto recomendadas / Anbefalede Reservedele
▲ Min. order size is 10 pcs. / Min. Auftragsgröße ist 10 Stück / Le volume minimum de la commande est de 10 pièces. / El tamaño de pedido mínimo son 10 pcs. / Minimumsalg 10 stk

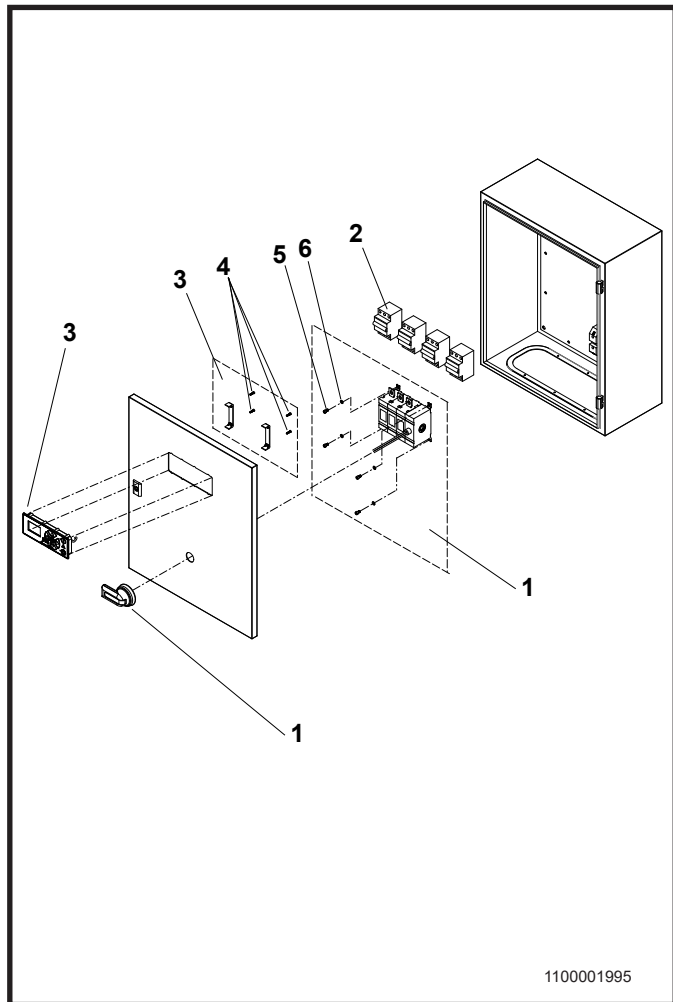
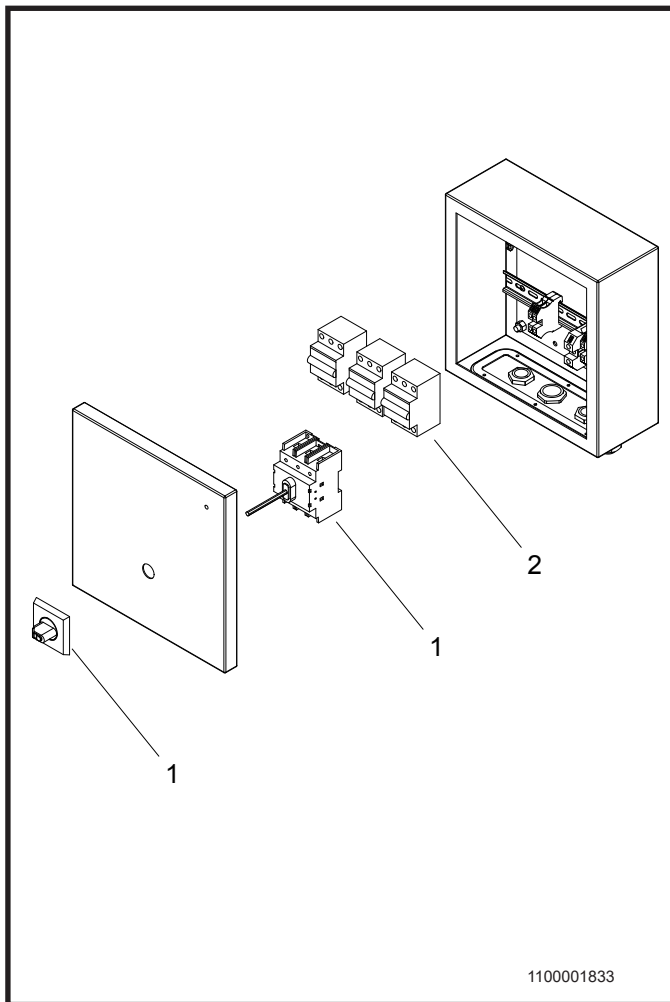

!	Nr. No.	Description Beschreibung Couvercle, unité principale Descripción Betegnelse	BF16 / BF16T	BF24 / BF24T	BF32 / BF32T	BF40 / BF40T	BF48 / BF48T
	1	110001857 Switch Schalter Interrupteur Commutador Afbryder	1	-	-	-	-
	1	110001858 Switch Schalter Interrupteur Commutador Afbryder	-	1	-	-	-
	2	110001859 Automatic fuse Automatische Sicherung Fusible automatique Fusible automático Automatsikring	2	3	4	5	6
		110001852 Electric cabinet complete BF16+ Elektrogehäuse komplett BF16+ Coffret d'Electric complet BF16+ Gabinete de Electric completo BF16+ Elskab kpl. BF16+					
		110001853 Electric cabinet complete BF24+ Elektrogehäuse komplett BF24+ Coffret d'Electric complet BF24+ Gabinete de Electric completo BF24+ Elskab kpl. BF24+					

!	Nr. No.	Description Beschreibung Couvercle, unité principale Descripción Betegnelse	BF16 / BF16T	BF24 / BF24T	BF32 / BF32T	BF40 / BF40T	BF48 / BF48T
	1	110001862 Switch Schalter Interrupteur Commutador Afbryder	-	-	1	1	1
	2	110001859 Automatic fuse Automatische Sicherung Fusible automatique Fusible automático Automatsikring	2	3	4	5	6
	3	110001841 Display complete Display komplett Afficheur complet Pantalla completa Display kpl.	1	1	1	1	1
	4	110001842 Screw kit Adv+ Schraube Set Adv+ Kit de Vis Adv+ Kit de Tornillos Adv+ Skrue kit Adv+					
▲	5	110001842 Screw kit Adv+ Schraube Set Adv+ Kit de Vis Adv+ Kit de Tornillos Adv+ Skrue kit Adv+					
▲	6	110001842 Screw kit Adv+ Schraube Set Adv+ Kit de Vis Adv+ Kit de Tornillos Adv+ Skrue kit Adv+					
		110001864 Electric cabinet complete BF32+ Elektrogehäuse komplett BF32+ Gabinete de Electric completo BF32+ Elskab kpl. BF32+					
		110001865 Electric cabinet complete BF40+ Elektrogehäuse komplett BF40+ Coffret d'Electric complet BF40+ Gabinete de Electric completo BF40+ Elskab kpl. BF40+					
		110001866 Electric cabinet complete BF48+ Elektrogehäuse komplett BF48+ Coffret d'Electric complet BF48+ Gabinete de Electric completo BF48+ Elskab kpl. BF48+					

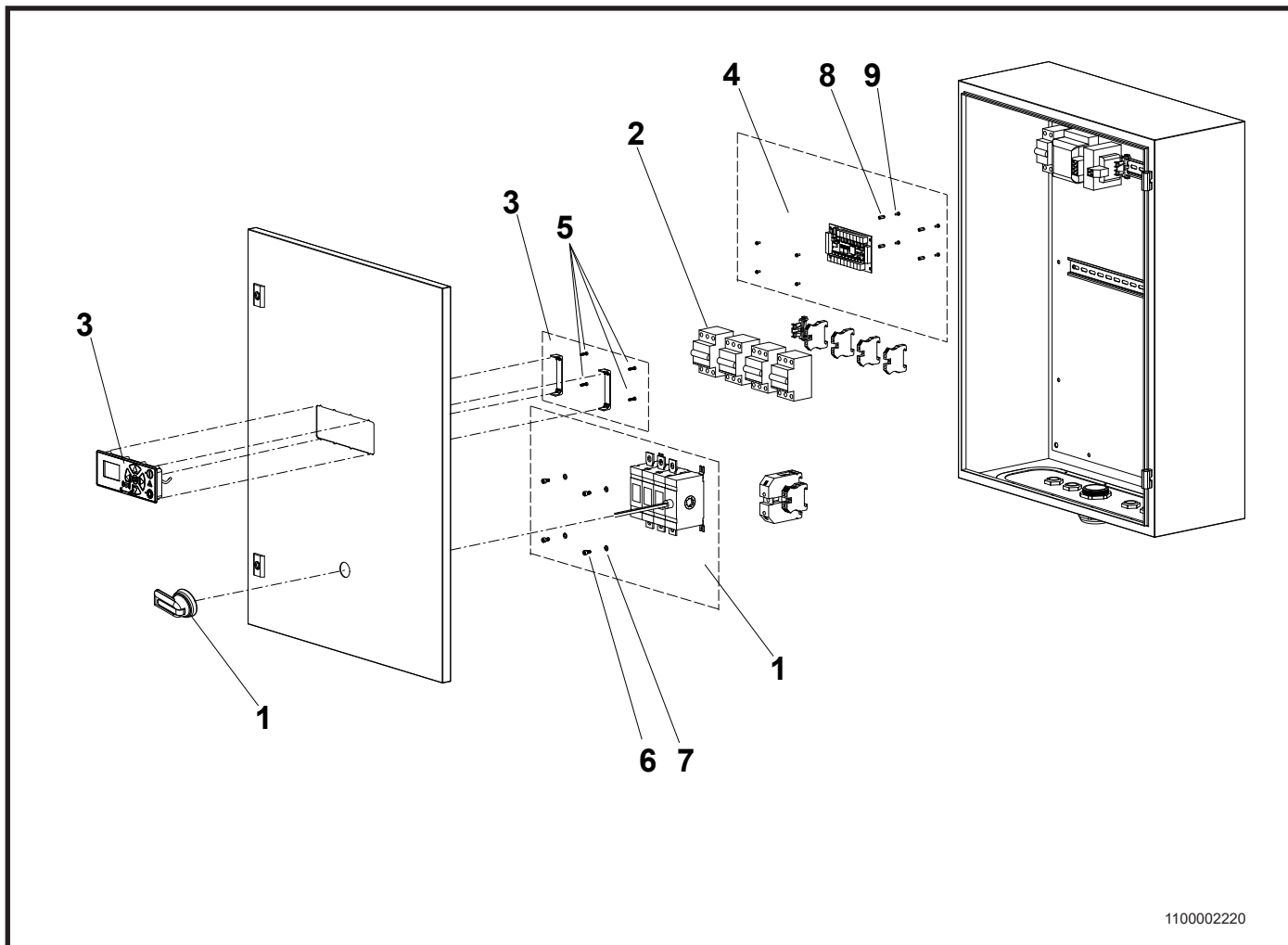

1100002220

!	Pos./Ref.	Nr. No.	Description Beschreibung Couverture, unité principale Descripción Betegnelse	BF16T	BF24T	BF32T	BF40T	BF48T
	1	110001857	Switch Schalter Interrupteur Conmutador Afbryder	1	-	-	-	-
	1	110001858	Switch Schalter Interrupteur Conmutador Afbryder	-	1	-	-	-
	1	110001862	Switch Schalter Interrupteur Conmutador Afbryder	-	-	1	1	1
	2	110001859	Automatic fuse Automatische Sicherung Fusible automatique Fusible automático Automatsikring	2	3	4	5	6
	3	110001841	Display complete Display komplett Afficheur complet Pantalla completa Display kpl.	1	1	1	1	1
	4	110002194	Printed Circuit Board Printerplatine Carte circuit imprimé Placa de circuito impreso Printkort	1	1	1	1	1
▲	5	110001842 (110000574)	Screw kit Adv+ Schraube Set Adv+ Kit de Vis Adv+ Kit de Tornillos Adv+ Skrue kit Adv+					
▲	6	110001842 (0600009)	Screw kit Adv+ Schraube Set Adv+ Kit de Vis Adv+ Kit de Tornillos Adv+ Skrue kit Adv+					
▲	7	110001842 (156302)	Screw kit Adv+ Schraube Set Adv+ Kit de Vis Adv+ Kit de Tornillos Adv+ Skrue kit Adv+					

!	Pos./Ref.	Nr. No.	Description Beschreibung Couverture, unité principale Descripción Betegnelse	BF16T	BF24T	BF32T	BF40T	BF48T
▲	8	110001842 (15010200)	Screw kit Adv+ Schraube Set Adv+ Kit de Vis Adv+ Kit de Tornillos Adv+ Skrue kit Adv+					
▲	9	110001842 (110002187)	Screw kit Adv+ Schraube Set Adv+ Kit de Vis Adv+ Kit de Tornillos Adv+ Skrue kit Adv+					
		110002210	Electric cabinet complete BF16T+ Elektrogehäuse komplett BF16T+ Coffret d'Electric complet BF16T+ Gabinete de Electric completo BF16T+ Elskab kpl. BF16T+					
		110002211	Electric cabinet complete BF24T+ Elektrogehäuse komplett BF24T+ Coffret d'Electric complet BF24T+ Gabinete de Electric completo BF24T+ Elskab kpl. BF24T+					
		110002212	Electric cabinet complete BF32T+ Elektrogehäuse komplett BF32T+ Coffret d'Electric complet BF32T+ Gabinete de Electric completo BF32T+ Elskab kpl. BF32T+					
		110002213	Electric cabinet complete BF40T+ Elektrogehäuse komplett BF40T+ Coffret d'Electric complet BF40T+ Gabinete de Electric completo BF40T+ Elskab kpl. BF40T+					
		110002214	Electric cabinet complete BF48T+ Elektrogehäuse komplett BF48T+ Coffret d'Electric complet BF48T+ Gabinete de Electric completo BF48T+ Elskab kpl. BF48T+					

* Recommended spare parts / Empfehlenswerte Ersatzteile / Pièces de rechange conseillées / Piezas de repuesto recomendadas / Anbefalede Reservedele

▲ Min. order size is 10 pcs. / Min. Auftragsgröße ist 10 Stück / Le volume minimum de la commande est de 10 pièces. / El tamaño de pedido mínimo son 10 pcs. / Minimumsalg 10 stk

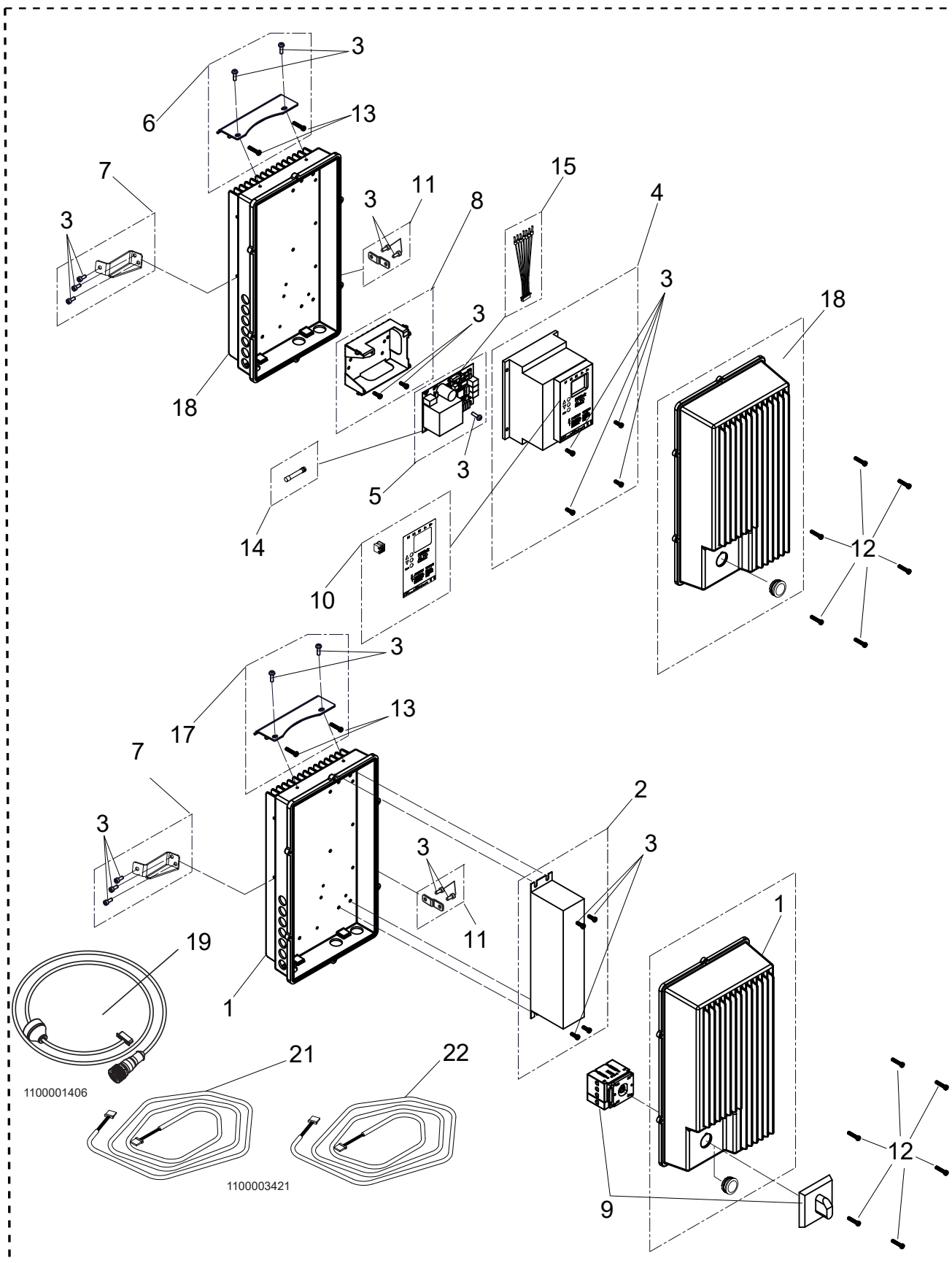

1100001406

1100003421

20

1100001990

Pos./Ref.	Nr. No.	Description Beschreibung Couvercle, unité principale Descripción Betegnelse	BF16 / BF16T	BF24 / BF24T	BF32 / BF32T	BF40 / BF40T	BF48 / BF48T
	1	110001131 Converter Box Stromrichterbox Boîtier de convertisseur Cuadro transformador El-kasse	2	3	4	5	6
	2	110001527 Noise Filter Geräuschfilter Filtre de bruit Filtro de ruido Støjfilter	2	3	4	5	6
▲	3	110001842 (0602104) Screw kit Adv+ Schraube Set Adv+ Kit de Vis Adv+ Kit de Tornillos Adv+ Skrue kit Adv+					
	4	110001466 11 kW Converter 11 kW Stromrichter Convertisseur 11 kW Transformador de 11 kW 11 kw omformer	2	3	4	5	6
*	5	110001843 Controller board + Bedienungstafel + Carte contrôleur + Placa de controlador + Controllerboard +	2	3	4	5	6
	6	110001860 Mounting Beschlag Montage Montaje Beslag	2	3	4	5	6
	7	110001381 Mounting Beschlag Montage Montaje Beslag	4	6	8	10	12
	8	110001244 Fitting complete controller print + Beschlag komplett Steuerungsprint + Montage contrôleur complet + Conector completo impresor controlador + Beslag kpl. Controllerprint +	2	3	4	5	6
	9	110001849 Switch Schalter Interrupteur Commutador Afbryder	2	3	4	5	6
	10	110001467 EPM Module + Converterlabel EPM Modul + Stromrichter etikette EPM Module + Convertisseur etiquette EPM módulo + Transformador etiqueta EPM Modul + Frekvensomformerlabel	2	3	4	5	6
	11	110001471 Mounting Beschlag Montage Montaje Beslag	4	6	8	10	12
▲	12	110001842 (0602125) Screw kit Adv+ Schraube Set Adv+ Kit de Vis Adv+ Kit de Tornillos Adv+ Skrue kit Adv+					
▲	13	110001842 (110001369) Screw kit Adv+ Schraube Set Adv+ Kit de Vis Adv+ Kit de Tornillos Adv+ Skrue kit Adv+					
	14	110001127 Fuse Sicherung Plomb Fusible Sikring	2	3	4	5	6
	15	110001128 Cable between controller and inverter Kabel zwischen Print und Frequenzumrichter Câble contrôleur et l'onduleur Cable el controlador y el inversor Kabel mellem print og frekvensomformer	2	3	4	5	6
	17	110001861 Mounting Beschlag Montage Montaje Beslag	2	3	4	5	6
	18	110001844 Converter Box Stromrichterbox Boîtier de convertisseur Cuadro transformador El-kasse	2	3	4	5	6
	19	110000971 Sensorcable Sensorkabel Sondet de câble Sensor de cable Sensorkabel	2	3	4	5	6
	20	110005373 Controller complete	2	3	4	5	6
	21	0631176 Network cable	1	2	3	5	6
	22	110003421 Cable for flowswitch	1	2	3	4	5

Pos./Ref.	Nr. No.	Description Beschreibung Couvercle, unité principale Descripción Betegnelse	BF16 / BF16T	BF24 / BF24T	BF32 / BF32T	BF40 / BF40T	BF48 / BF48T

* Recommended spare parts / Empfehlenswerte Ersatzteile / Pièces de rechange conseillées / Piezas de repuesto recomendadas / Anbefalede Reservedele
▲ Min. order size is 10 pcs. / Min. Auftragsgröße ist 10 Stück / Le volume minimum de la commande est de 10 pièces. / El tamaño de pedido mínimo son 10 pcs./ Minimumssalg 10 stk

Printed in Denmark

No.: 110004337E/ 110004337E 10/2021
Serial no: 106.01.00000x