USER MANUAL

MODEL NUMBER:

SS2

SS2-FMH

SS2-MBS

AND RELATED UNITS

Footwear Sanitation System

English (Original Instructions)

READ ALL INSTRUCTIONS BEFORE OPERATING EQUIPMENT

WARNING



Read this manual completely and understand the machine before operating or servicing it.

- Read all instructions before operating or interacting with this unit.
- Always wear appropriate personal protective equipment (PPE) when operating or servicing unit.
- Always follow all chemical safety precautions and handling instructions provided by the chemical manufacturer and Safety Data Sheet (SDS).
- If this unit is modified or serviced with parts not listed in this manual, the unit may not operate correctly.
- This unit is for use with fully protective footwear only.
- Chemical Spray Hazard
 - o Insert foot fully into unit and press down with heel. Partial insertion may cause chemical spray to face and eyes.
 - o Wear splash goggles when required by chemical manufacturer, SDS, or OSHA.
 - o Do not remove or modify spray guard.
- Always disconnect the unit from compressed air before performing any maintenance.
- Do not exceed an incoming air pressure of 130psi (8.9 bar).
- Do not exceed a fluid temperature of 100°F (37°C).
- Never use unit with hydrocarbons.

PROTECT THE ENVIRONMENT

Please dispose of packaging materials, old machine components, and hazardous fluids in an environmentally safe way according to local waste disposal regulations.



Always remember to recycle.

*Specifications and parts are subject to change without notice.

INTENDED USE

This machine is designed to help sanitize footwear at transition zones with a focus on reduced moisture. This machine is intended to sanitize shoe soles and not intended for any other use.

OPTIONS

		System Add-On
SS2	-	None (<i>standard</i>)
		Floor mounted handle (FMH)
		Manual boot scrubber (MBS)

Add bold option codes to item number as shown. For standard options, no option code is needed.

Examples:

- SS2 (standard unit)
- SS2-FMH (unit with floor mounted handle)
- SS2-MBS (unit with manual boot scrubber)

READ ALL INSTRUCTIONS BEFORE OPERATING EQUIPMENT

REQUIREMENTS	
Compressed air requirements	40-60 psi (2.8-4.1 bar) with 1 cfm (28.3 l/min)
Recommended operating air pressure	40 psi (2.8 bar) with 1 cfm (28.3 l/min)
Liquid temperature range	40-100°F (4-37°C)
Chemical compatibility	Chemical products used with this equipment must be formulated for this type of application and compatible with unit materials and pump seals. For more information on chemical compatibility, consult the manufacturer or SDS for your product or contact our Tech Support department.

SPECIFICATIONS	
Power type	Compressed air
Chemical pickup type	Draws from pre-mixed product
Number of products unit can draw from	One product
Suction line length/diameter	3 ft. (0.9 m) clear hose with 1/4 in. (6.4 mm) inside diameter
Output volume*	0.2 oz. (5.9 mL) per spray
Pump seals	Viton
Number of nozzles	4 nozzles
Dimensions (LxWxH)	SS2: 24.7x11x18 in. (62.7x27.9x45.7 cm) approximately SS2-FMH: 27.1x15.7x41.5 in. (68.9x39.9x105.4 cm) approximately SS2-MBS: 28.7x29.2x40.3 in. (72.9x74.2x102.4 cm) approximately
Weight	SS2: 24 lbs (10.9 kg) approximately FMH: 16 lbs (7.3 kg) approximately, SS2-FMH: 40 lbs (18.1 kg) approximately MBS100-C: 34 lbs (15.4 kg) approximately, SS2-MBS: 58 lbs (26.3 kg) approximately
Noise level	Less than 70 dB(A)

*Dilution rates and flow rates given are based on chemical with viscosity of water and factory air pressure settings.

READ ALL INSTRUCTIONS BEFORE OPERATING EQUIPMENT

LIFT POINTS:

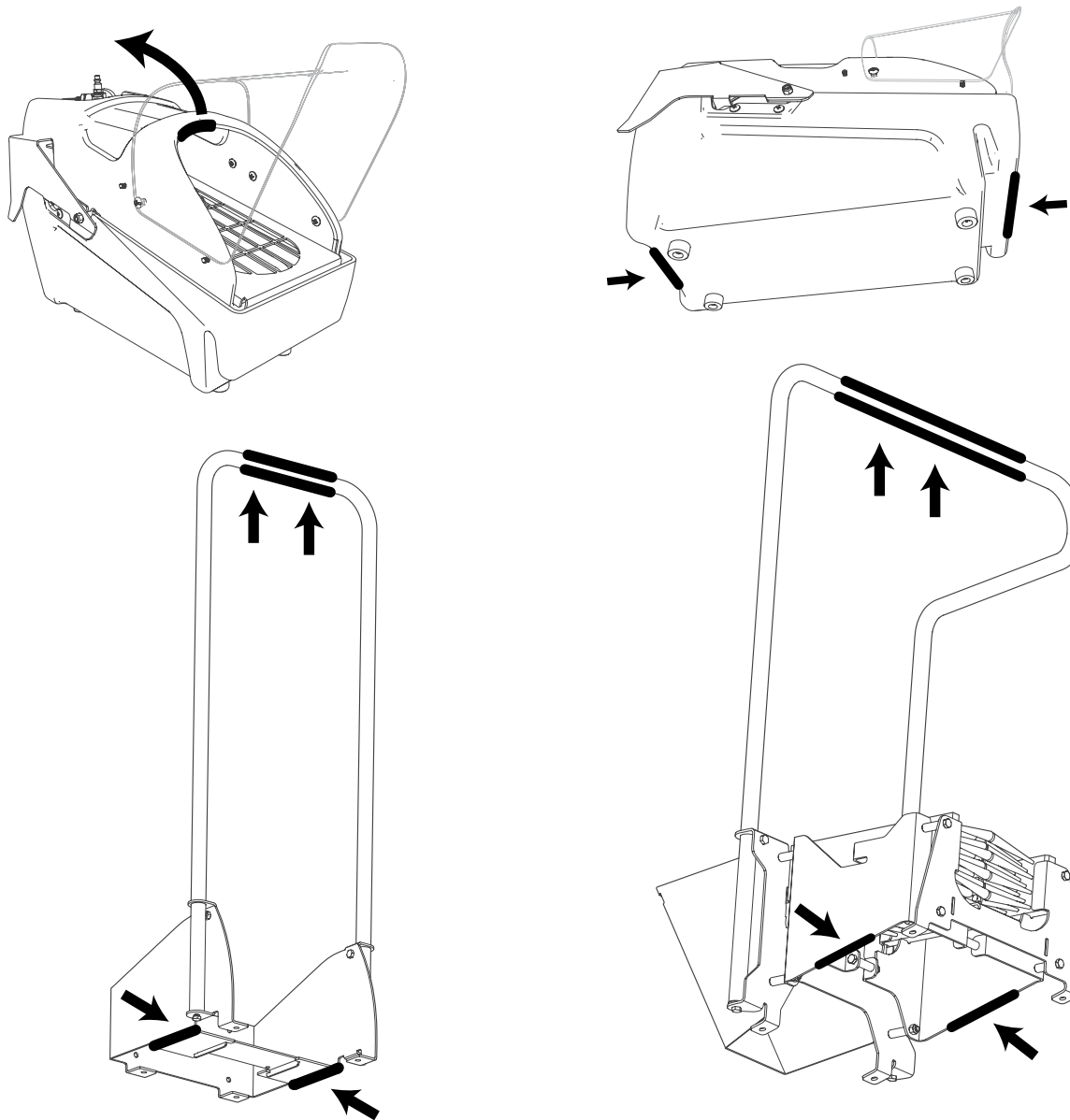

INSTRUCTIONS:

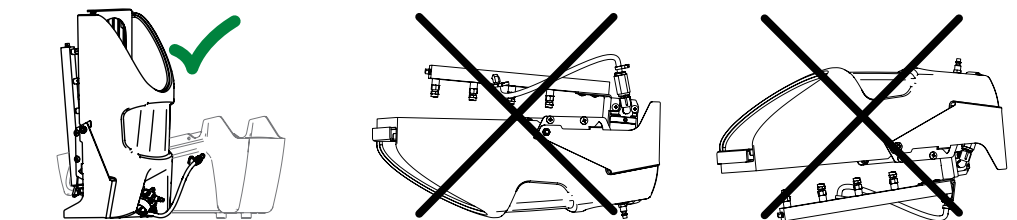

READ ALL INSTRUCTIONS BEFORE OPERATING EQUIPMENT

Installation Instructions:

For SS2 Unit:

1. Position footwear sanitizing unit in desired location.
2. If desired, mount the chemical jug to the wall using the provided mounting hardware (WMS14, WMS14A) and rack (SSJR2). The chemical jug should not be mounted higher than 30 in. (0.7 m) above the unit. Suction hose length should not exceed 8 ft. (2.4 m).
3. Connect an air line to the air fitting (AP25).
4. Follow all instructions from chemical manufacturer. Fill the chemical jug (J2.5BKSR) with pre-mixed or ready-to-use chemical solution and connect the suction line to the jug suction fitting.
5. Prime the unit according to the Priming Instructions.

For SS2-FMH Unit:

1. Select desired location to mount footwear sanitizing unit.
2. Attach handle (FS-HNDL) to handle bracket (FS-FMB) with bolts (B5161834) on the ends. Secure with set screws (B5161834 and LNSS516).
3. Mount handle assembly to floor or wall (hardware not included).
4. Lift up on the shroud (SS2-SH), rotate the top half of the unit, and slide top half of unit from the bracket (FS-GUARD) to release from the base.

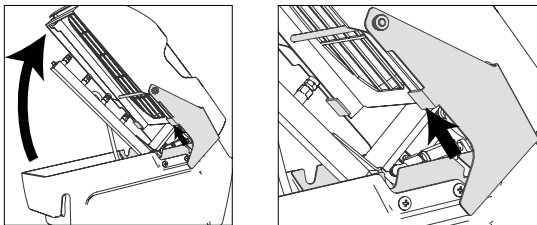

5. Hook the plate (FS-FMP) on the underside of the collection basin to the bracket at the base of the mounting handle.

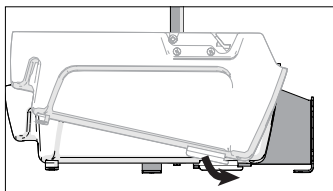

6. If desired, mount the chemical jug to the wall using the provided mounting hardware (WMS14, WMS14A) and rack (SSJR2). The chemical jug should not be mounted higher than 30 in. (0.7 m) above the unit. Suction hose length should not exceed 8 ft. (2.4 m).

7. Connect an air line to the air fitting (AP25).
8. Follow all instructions from chemical manufacturer. Fill the chemical jug (J2.5BKSR) with pre-mixed or ready-to-use chemical solution and connect the suction line to the jug suction fitting.
9. Prime the unit according to the Priming Instructions.

For SS2-MBS Unit:

1. Select desired location to mount footwear sanitizing system.
2. Attach handle (FS-HNDL-C) to boot scrubber base (MSC100-C-BASE) with bolts (B5161834) on the ends. Secure with set screws (B5161834 and LNSS516).
3. Slide debris tray (DBTR) under boot scrubber, lift up and hook tray into slots on front of the boot scrubber frame to secure.
4. Connect debris shield (DBSH) by sliding hooks into the slots on the back the boot scrubber frame. Note: Brushes (BR10S) must be removed before installing/uninstalling debris shield.
5. Position boot scrubber in desired location and mount to floor (hardware not included).
6. Position mounting bracket (FS-BPL) for footwear sanitizer next to the boot scrubber and secure to the floor (hardware not included).
7. Hook the plate (FS-FMP) on the underside of the collection basin to the mounting bracket (FS-BPL).

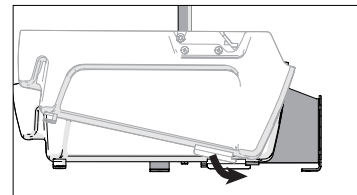

8. If desired, mount the chemical jug to the wall using the provided mounting hardware (WMS14, WMS14A) and rack (SSJR2). The chemical jug should not be mounted higher than 30 in. (0.7 m) above the unit. Suction hose length should not exceed 8 ft. (2.4 m).
9. Connect an air line to the air fitting (AP25).
10. Follow all instructions from chemical manufacturer. Fill the chemical jug (J2.5BKSR) with pre-mixed or ready-to-use chemical solution and connect the suction line to the jug suction fitting.
11. Prime the unit according to the Priming Instructions.

READ ALL INSTRUCTIONS BEFORE OPERATING EQUIPMENT

⚠ WARNING: Chemical Spray Hazard

- Insert foot fully into unit and press down with heel. Partial insertion may cause chemical spray to face and eyes.
- Wear splash goggles when required by chemical manufacturer, SDS, or OSHA.
- Do not remove or modify spray guard.

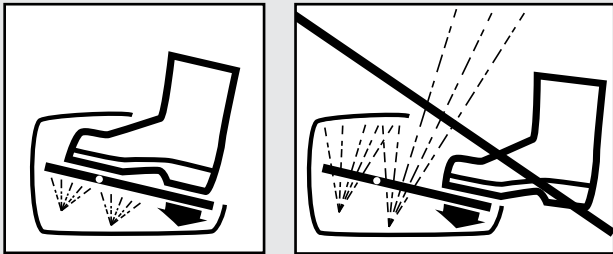

Priming Instructions:

Note: This unit is for use with fully protective footwear only. Do not activate the unit if a user's foot is not positioned inside the spray guard (SS2-SH).

1. Verify that the chemical jug (J2.5BKSR) is full, and connect the jug to the unit suction line. Check all tubing connections and verify that none are loose or leaking.
2. Place foot on the grate (FS-GRATE) and step down with heel 10-15 times or until all air has been purged from the suction line.
3. Check bottom of footwear for proper sanitizer application. The entire sole should be covered with a consistent spray pattern.

Operation Instructions:

For SS2 Unit:

1. Place one foot on the grate (FS-GRATE) and step down with heel to activate the spray.
2. Repeat the process with your other foot.

For SS2-FMH Unit:

1. Grip the handle (FS-HNDL) with both hands to establish 3 points of contact.
2. Place one foot on the grate (FS-GRATE) and step down with heel to activate the spray.
3. Repeat the process with your other foot.

For SS2-MBS Unit:

1. Grip the handle (MBS-HNDL) above the manual boot scrubber with both hands to establish 3 points of contact.
2. Place one foot in the brushes and push foot back and forth to remove debris. Repeat the process with your other foot.
3. Move to the footwear sanitizer and grip the handle (FS-HNDL) above with both hands to establish 3 points of contact.
4. Place one foot on the grate (FS-GRATE) and step down with heel to activate the spray.
5. Repeat the process with your other foot.

READ ALL INSTRUCTIONS BEFORE OPERATING EQUIPMENT

Maintenance Instructions:

The unit should be cleaned regularly to ensure that it is in a clean condition. Cleaning schedule will depend on frequency of use and types of soils. Follow daily maintenance instructions to keep the unit clean; clean more often if necessary. Clean parts by any method suitable for the material type and safe for the facility environment. For example: use food-safe cleaner and food-safe material in a food processing facility.

Always wear appropriate personal protective equipment (PPE) when operating or servicing unit.

Before performing any maintenance, disconnect the unit from the compressed air supply. After maintenance is complete, reconnect compressed air, verify suction line and fittings are secure, and re-prime the unit according to the Priming Instructions.

Daily Maintenance for SS2, SS2-FMH, and SS2-MBS Units:

- Inspect the stainless foot grate (FS-GRATE) and shroud (SS2-SH) for soil and wipe clean.
- Wipe clean the polycarbonate spray guard (SS2-SPGRD).
- The basin (SS2-H) should be emptied and cleaned each time the chemical supply container is changed or refilled. Follow instructions on how to clean collection basin (SS2-H).
- Verify that the nozzle assembly is free of any debris or blockage. Rinse with low pressure water if necessary.
- Inspect all tubing for leaks or excessive wear. Make sure all hose clamps and push fittings are in good condition and properly secured.

Daily Maintenance for SS2-MBS Unit Only:

- Remove brushes (BR10 and BR10S) by lifting them out from the brush bracket. Remove debris and clean. Brushes should be replaced every 6 months depending on wear.
- Slide out debris tray (DBTR). Empty debris and wipe clean.
- Lift up on debris shield (DBSH) to remove.
- Base assembly of the unit is fully stainless and can be cleaned in place by any method suitable for stainless steel.

How To Clean Collection Basin (SS2-H):

- Empty collection basin (SS2-H)
 - a. Lift up on the shroud (SS2-SH), rotate the top half of the unit, and slide top half of unit from the bracket (FS-GUARD) to release from the base.

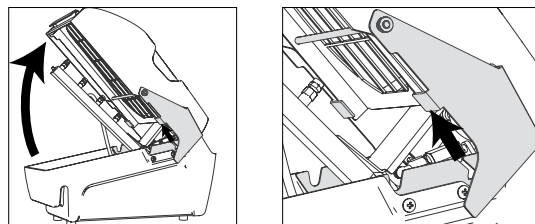

- b. Stand top half of unit on short end. Setting unit down in other position may cause damage to nozzle assembly.

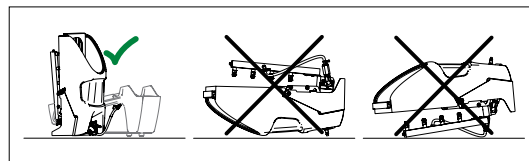

- c. Grab handle on front of collection basin and tip up to empty.
- d. Slide top half of unit back into place on collection basin.

READ ALL INSTRUCTIONS BEFORE OPERATING EQUIPMENT

Maintenance Instructions continued:

Other Maintenance for SS2, SS2-FMH, and SS2-MBS Units:

- Inspect all parts of the unit regularly, and clean if necessary.

PARTS MATERIAL LIST:

DESCRIPTION	ITEM NUMBER	MATERIAL TYPE
Manifold	MN186	PVC
Nozzles	FCN120	PVDF
Checks	CV18MFSS	stainless steel
Mounting frame	FS-FRAME	stainless steel
Pump	PSS02	polypropylene
Check valves	CV14M14B-R, CV14M14B-L	PVC
Shroud	SS2-SH	polyethylene
Spray guard	SS2-SPGRD	polycarbonate
Clear tubing	H14C, H38C	PVC
Red/Blue tubing	H14BU	polyurethane
Roller cam	RCA	stainless, nylon
Two-way air valve	SS1B2WV	brass body with stainless steam
Other metal fittings	N/A	stainless steel
Other plastic fittings	N/A	polypropylene

Troubleshooting Instructions:

If footwear sanitizing unit will not spray:

- Check valve stem (SS1B2WV valve stem) and roller cam (RCA) to ensure proper movement and compression (Refer to Figure 1 below)
- If the pump is cycling, but the unit does not spray, the pump may be air locked.
- Check the suction line and strainer for debris and clean if necessary.

FIGURE 1

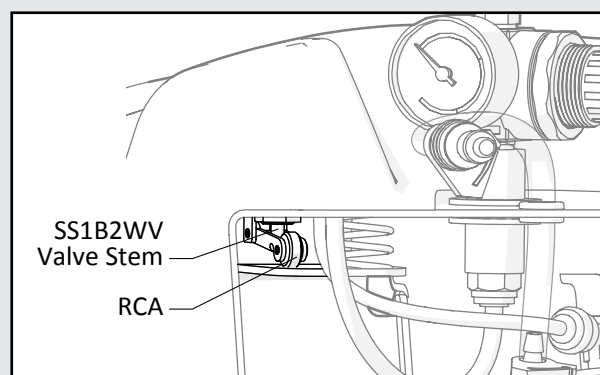

If footwear sanitizing unit sprays irregularly:

- Verify that the unit is connected to an appropriate compressed air source. This unit requires 40 psi (2.8 bar) with 1 CFM (28.3 l/min) to operate. To maximize unit lifespan and performance, compressed air should be clean and dry. Note: If air source has a high moisture content, install a water separator (WS-20CFM) before the unit.
- Verify the pump is cycling regularly. The pump can be disassembled and the o-ring can be relubricated with a silicone-based lube.
- Check the spray tips (FCN120) and make sure they are not clogged or blocked by debris. The spray tips may be removed and cleaned if necessary.

If the unit does not hold a prime:

- Check hose clamps and ensure that barbs are secure.
- Check all tubing connections and verify that none are loose, broken, or leaking.

READ ALL INSTRUCTIONS BEFORE OPERATING EQUIPMENT

PARTS DIAGRAMS - UNITS WITH STANDARD FITTINGS

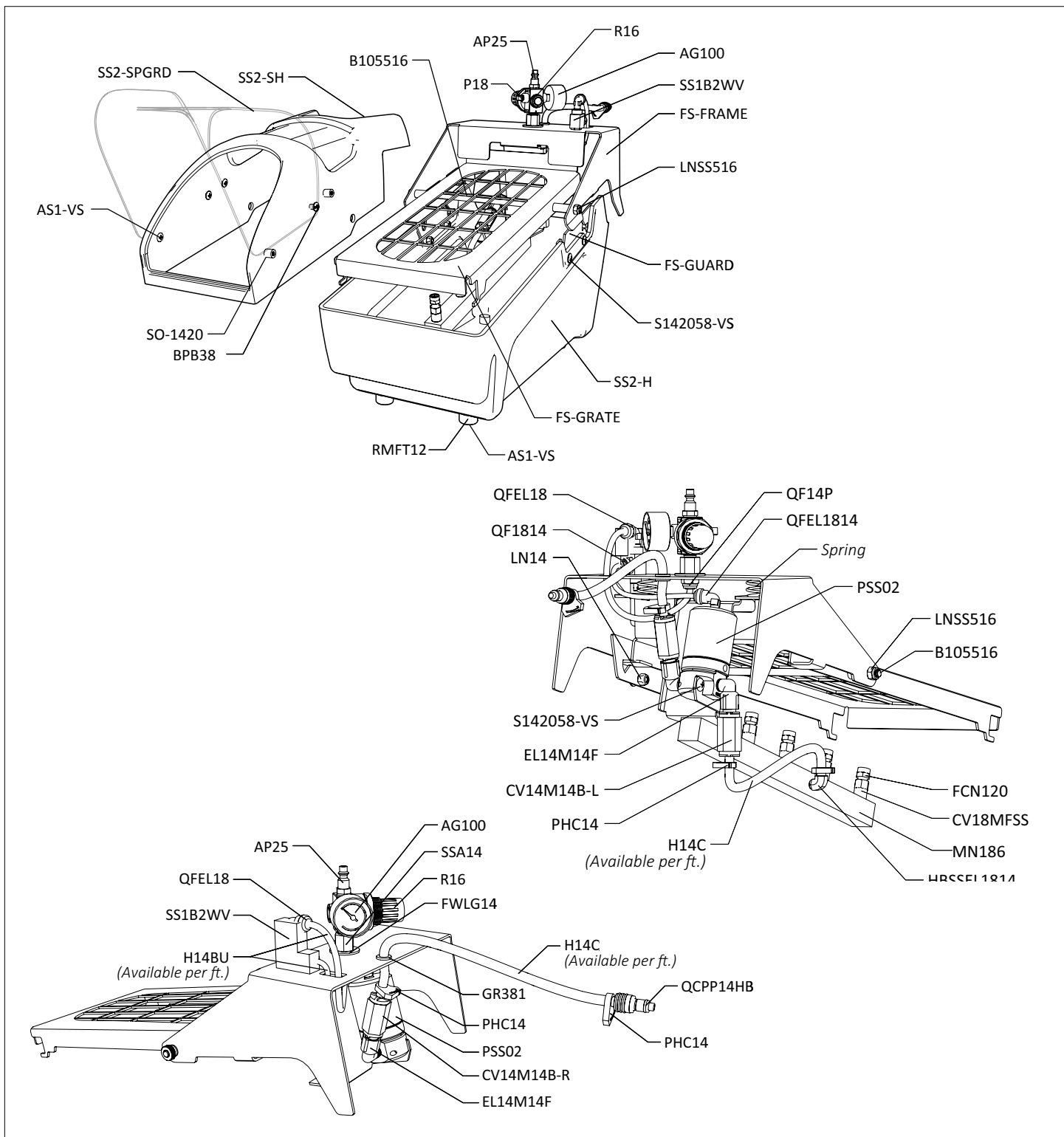

READ ALL INSTRUCTIONS BEFORE OPERATING EQUIPMENT

PARTS DIAGRAMS

**MANUAL BOOT SCRUBBER ASSEMBLY
ITEM NUMBER: MBS100-C**

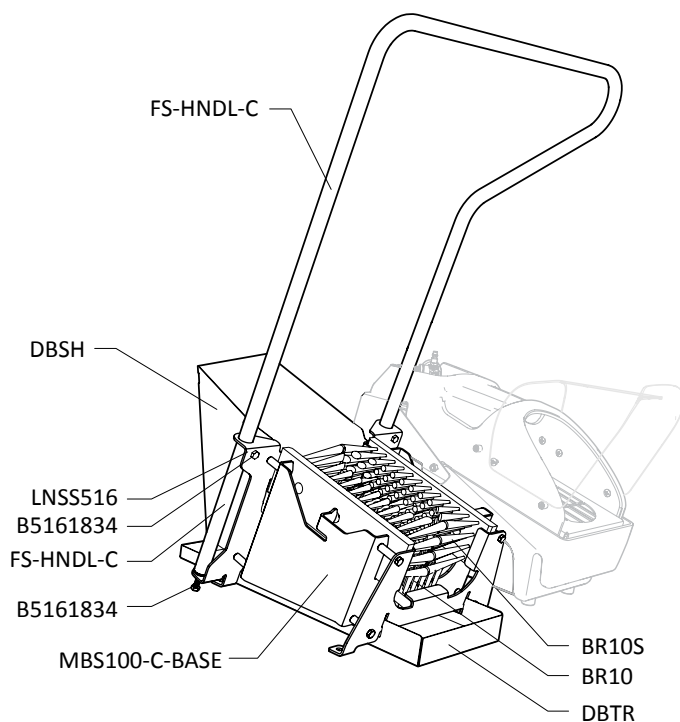

**MBS100-C MOUNTING PLATE FOR SS2
ITEM NUMBER: FS-BPL**

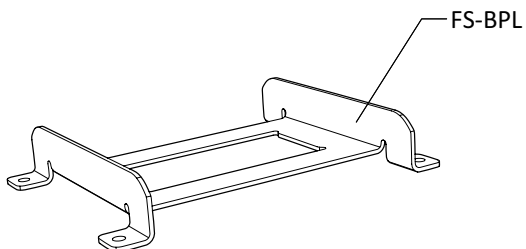

**FLOOR MOUNTED HANDLE ASSEMBLY
ITEM NUMBER: FMH**

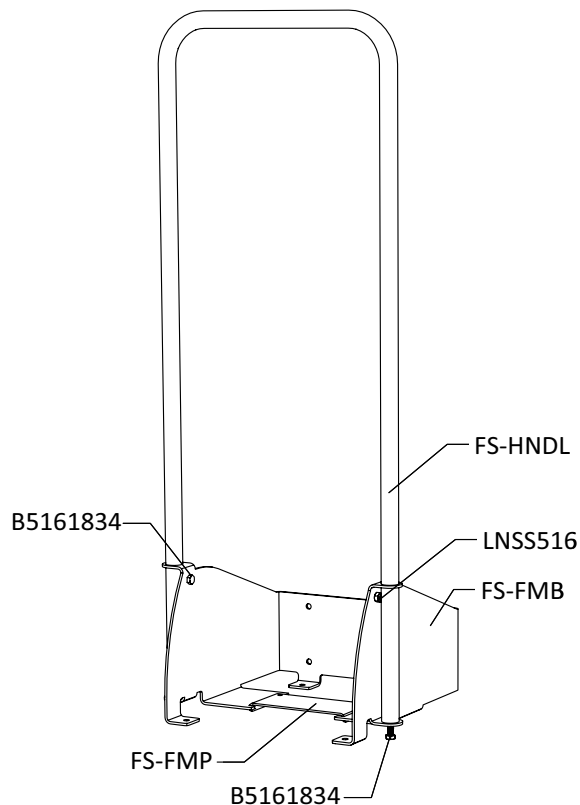

READ ALL INSTRUCTIONS BEFORE OPERATING EQUIPMENT

PARTS DIAGRAMS

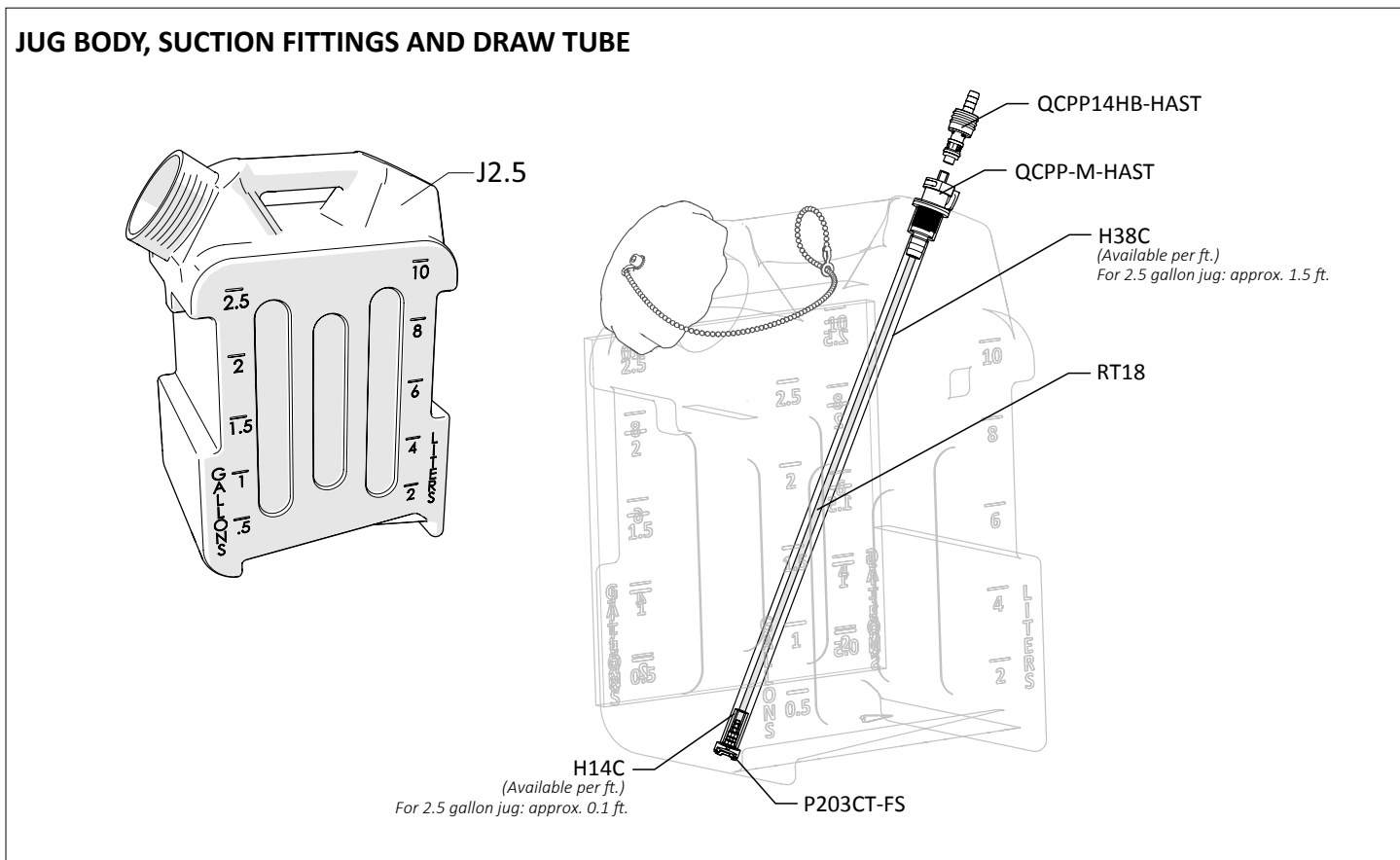
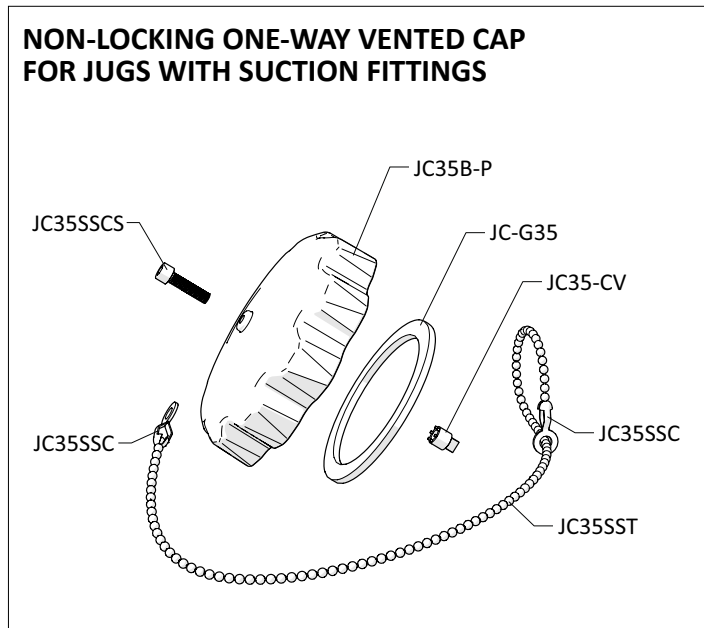
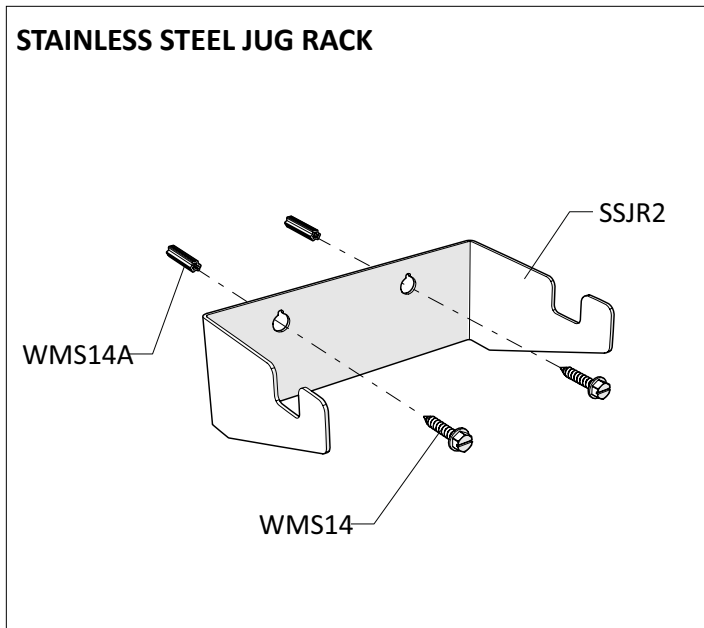

READ ALL INSTRUCTIONS BEFORE OPERATING EQUIPMENT

PARTS LIST

ITEM NUMBER	DESCRIPTION
AG100	1.5 INCH DRY MODEL 20 DUAL SCALE GAUGE
AP25	AIR FITTING 1/4 MPT X PLUG-BRASS
AS1-VS	1/4-20 X 1/2 PHIL TRUSS MACH SCREW 19-8 W/516 ORANGE VIBRASEAL PATCH
B105516	BOLT-11.25 IN LONG-5/16 DIAMETER-18TPI
B5161834	HEX HEAD 5/16-18 X 3/4 IN
BPB38	BINDING POST BARREL - 3/8IN LONG - SS
BR10	MBS SOLE BRUSH 10.5 X 3 - POLYPROPYLENE
BR10S	MBS SIDE BRUSH 12.5 X 3.44 - POLYPROPYLENE
CV14M14B-L	1/4 MNPT X 1/4 BARB PVC CHK-302SS SPRING-VITON SEALS-AIR FLOW LEFT
CV14M14B-R	1/4 MNPT X 1/4 BARB PVC CHK-302SS SPRING-VITON SEALS-AIR FLOW RIGHT
CV18MFSS	1/8 MPT X 1/8 FPT SS CHECK VALVE-1 LB SS SPRING-VITON SEALS
DBSH	DEBRIS SHIELD FOR MBS100-C
DBTR	DEBRIS TRAY FOR MBS100-C
EL14M14F	1/4 FPT X 1/4 MPT - POLYPRO ELBOW
FCN120	FULL CONE NOZZLE-120 DEGREES-0.26GPM-PVDF
FS-BPL	BASE PLATE FOR MOUNTING SS2 TO FLOOR
FS-FMB	FLOOR MOUNT BRACKET FOR SS2
FS-FMP	FLOOR MOUNT PLATE FOR SS2 (MOUNTS TO BOTTOM OF SS2)
FS-FRAME	STAINLESS HARDWARE MOUNTING FRAME FOR SS-2
FS-GRATE	STAINLESS FOOT GRATE FOR SS2
FS-GUARD	SS PIVOT PLATE FOR SS2
FS-HNDL	HANDLE BAR FOR SS2
FS-HNDL-C	HANDLE BAR FOR SS2-MBS COMBO
FWLG14	.569 ID X 1.28 OD X .08 THICK FLAT WASHER SS 18-8
GR381	GROMMET-3/8IN ID, 5/8IN OD, 3/32IN Thick for 7/16IN Diameter Panel Hole
H14BU	1/4in OD BLUE POLYURETHANE TUBING - Available per ft.
H14C	1/4in ID (3/8 in OD) CLEAR POLYVINYL TUBING - Available per ft.
H38C	3/8in CLEAR PVC TUBING - Available per ft.
HBSEL1814	STAINLESS HOSE BARB 1/8 MPT X 1/4 BARB ELBOW
J2.5	2.5 GALLON NATURAL JUG
JC35B	BLACK 3.5 INCH ONE WAY VENTED CAP POLYPROPYLENE WITH GASKET AND CHECK VALVE
JC35B-P	BLACK 3.5 INCH CAP - POLYPROPYLENE
JC35-CV	EPDM CHECK VALVE FOR NON LOCKING JUG CAP
JC-G35	JUG CAP GASKET 3.5 INCH CAP EPDM

ITEM NUMBER	DESCRIPTION
JC35SSC	304 SS END COUPLING FOR SIZE 8-10, ROUND BEAD CHAIN
JC35SSCS	SOCKET HEAD CAP SCREW-10-32 MPT-3/4IN LONG-VENTED
JC35SST	ROUND BEAD CHAIN, TYPE 304 STAINLESS STEEL, #10
LN14	1/4-20 NE NYL INS LOCKNUT 18-8 PLN
LNSS516	5/16-18 HEX NYLON INSERT LOCKNUT 18-8 PLN NE
MBS100-C-BASE	BASE OF BOOT SCRUBBER
MN186	MANIFOLD-1/8IN NPT-6 PORTS-PVC
P18	PLUG 1/8 MPT HEX HEAD 304 SS
P203CT-FS	FOOT STRAINER FOR THE P203CT
PHC14	BLACK POLY HOSE CLAMP
PSS02	PUMP-SINGLE SHOT-AIR OPERATED-0.2 OZ PER SHOT-1/4IN PORTS
QCPP14HB-HAST	1/4IN IN-LINE HOSE BARB - POLYPRO BODY - HASTELLOY SPRING
QCPP-M-HAST	3/8IN PANEL MOUNT SOCKET - SUCTION 3/8 ID X QUICK CONNECT - HASTELLOY SPRING
QF14P	QUICK FIT-1/4 MPT X 1/4 OD TUBE-POLYPROPYLENE
QF1814	QUICK FIT-1/8 MPT X 1/4 OD TUBE-POLYPRO
QFEL18	FIXED ELBOW 1/4in TUBE X 1/8in MPT - BRASS
QFEL1814	FIXED ELBOW 1/8in MPT X 1/4in TUBE - POLYPROPYLENE
R16	AIR REGULATOR - 1/4fpt TWO PORT 1/8fpt TWO PORT - NO AIR BOWL/FILTER
RCA	ROLLER CAM ACTUATOR
RMFT12	RUBBER MOLDED FEET-1/2 IN TALL
RT18	RIGID POLYPRO TUBING-18 INCHES IN LENGTH (0.17 INCH ID- 1/4 INCH OD)
S142058-VS	1/4-20 X 5/8 PHIL TRUSS MACHINE SCREW 18-8 W/#516 VIBRASEAL ORANGE PATCH
SO-1420	ROUND STANDOFF - 1/4-20 FEMALE THREADS
SPG-PSS02	SPRING FOR PUMP-PSS02
SS1 UCS	SS1 U-CUP SEAL, VITON
SS1B2WV	BRASS TWO WAY AIR VALVE
SS2-H	SS2 FOOTWEAR SANITIZER HOUSING
SS2-SH	SS2 FOOTWEAR SANITIZER SHROUD
SS2-SPGRD-P	SPRAY GUARD FOR SS2 UNITS
SSA14	STAINLESS ADAPTOR 1/4 MPT X 1/4 FPT
SSJR2	SPRAY GUARD FOR SS2 UNITS
WMS14	14 X 1 1/4 HEX W/H SMS SLOTT, S/S
WMS14A	5/16 X 1 1/2 STRAIGHT PLASTIC ANCHO