



Professional Main Station MM Series



Content EN

1. Description	3
1.1 Mainstations MM35-MM37-MM45-MM47-MM85-MM87	4
1.2 Operating diagrams.....	5
2. Maintenance	6
2.1 Filter	6
2.2 Long Stops	6
3. Start	6
3.1 New System	6
4. Daily Operation	6
4.1 Start.....	6
4.2 Stop.....	7
4.3 Rinsing the Chemistry supply.....	7
5. Service.....	7
5.1 Components.....	7
5.1.1 Pumps / Motor.....	7
5.1.2 Control system	7
5.1.3 Flow trigger	7
5.1.3.1 Adjustments	7
5.4 Non-return valve / intake side	7
6. Trouble Shooting.....	8
6.1 The Unit does not start.....	8
6.2 The "Δ" lamp on the control panel is on	9
6.3 Too low or unstable pressure	9
6.4 Unsatisfactory foam quality.....	9
7. Recommended Spare Parts.....	10
7.1 Connection of Controller board and mounting of sensor.....	11
8. Specifications.....	12

1. Description

The main station in the Chameleon range is a completely functioning hygiene and pumping station that supplies pressurized water to both its integrated hygiene point and to connected satellite hygiene stations. Therefore the main station must be supplied with: water in sufficient quantity, power, compressed air, detergent(s) and disinfectant. The station is then ready for hygiene duties..

The change between rinse and foam on the first injector is manual. To change to another injector/product the hose must be moved between the outlets. The main station is fitted with a frequency controlled pump which ensures a constant working pressure independent of usage pattern.

Important: Do not use the water from the system for applications other than cleaning.

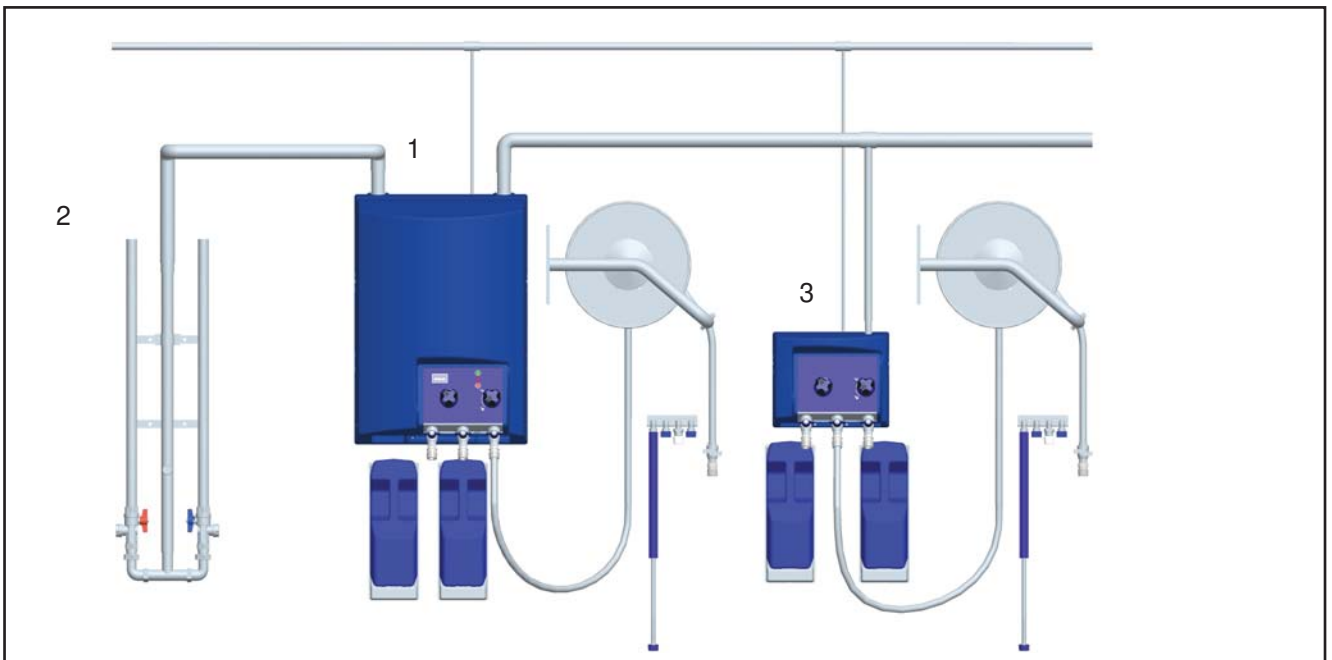

Fig. 1

0627089

Using Hygiene Chemicals:

The Professional main station has been prepared to use Ecolab's European palette of foam detergents and disinfectants.

Warning

Do not change the settings made or recommended by the supplier of hygiene chemicals.

A typical installation of the Professional series is shown in fig. 1

- Main station (1)
- Mixing system (2)
- Satellite (3)

Detergents are supplied either from the User Pack System, which can be ordered and delivered as an accessory or from separate standard cans. Hygiene chemicals can also be supplied directly through piping systems.

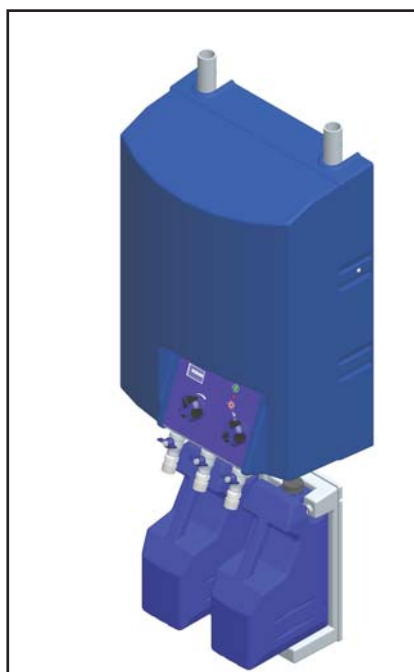

Fig. 2

0627118

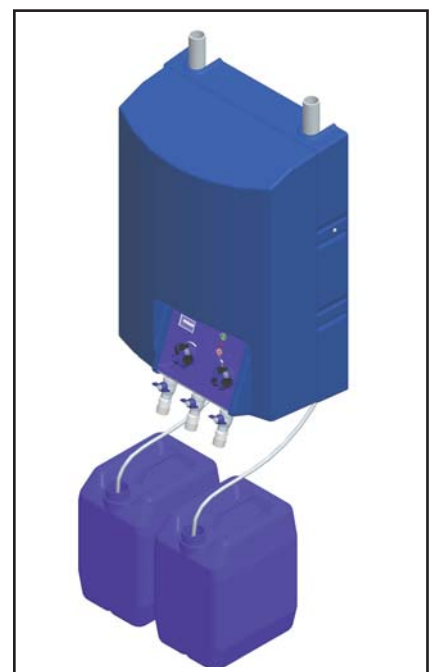

Fig. 3

0627114

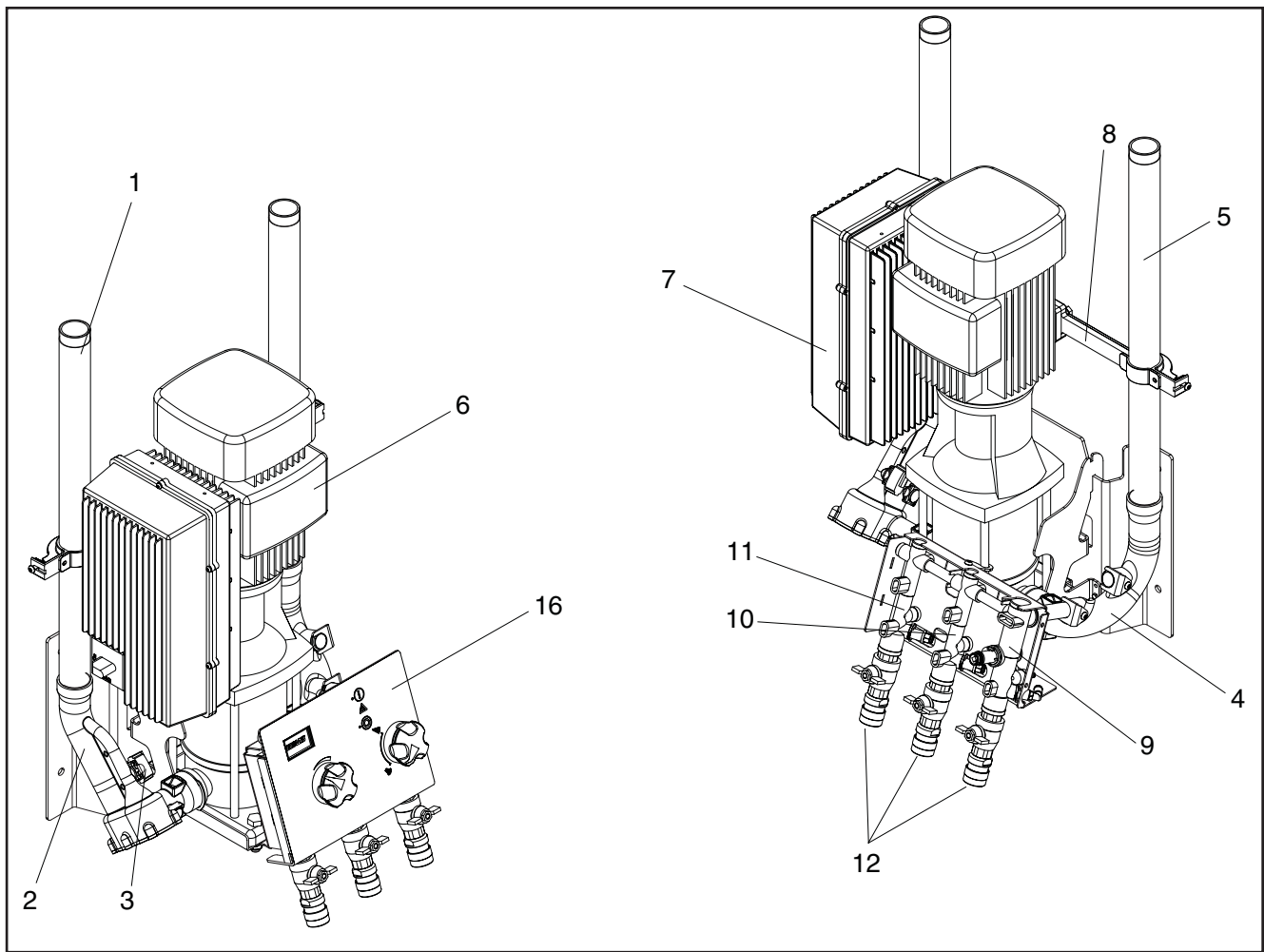

Fig. 4

0627122

Main Stations

MM1-MM35-MM37-MM45-MM47-MM85-MM87(Fig. 4).

1. Water inlet
 2. Manifold input
 3. Trigger sensor, Flow sensor
 4. Manifold outlet
 5. Outlet pipe
 6. Pump
 7. Converter box
 8. Pipe holder, fittings
 9. Injector, chemistry 1
 10. Injector, chemistry 2
 11. Injector, chemistry 3
 12. Quick coupling with check tap
 13. Display
 14. Change-over switch foam/rinse
 15. Air regulator
 16. Operation panel
- ○ Pushbutton. Stop
 - I Pushbutton. Start
 - Δ Lamp. Alight by error

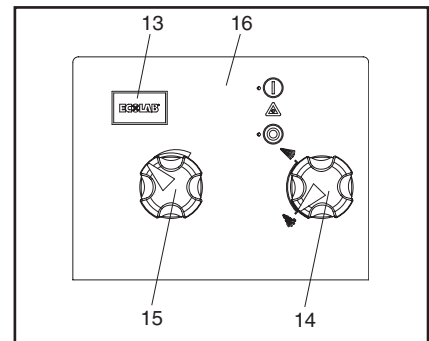

Fig. 5

0627142

1.1 Operating diagrams according to. ISO14617

Main stations MM

- B. Ball valve.
- F. Filter.
- FST. Flowsensor and -trigger.
- C. Check valve.
- PE. Pressure sensor.
- TE. Temperature sensor.
- CP. Centrifugal pump.
- EJ. Ejector.
- HV. Hydraulic valve.
- HC. Hose connection.
- PR. Pressure regulator.
- COV. Change over valve.
- OF. Orifice.
- A. Air supply.
- D. Outlet.
- E. Inlet, Ecolab detergent.
- W. Water inlet.
- JPx : Control board connection.

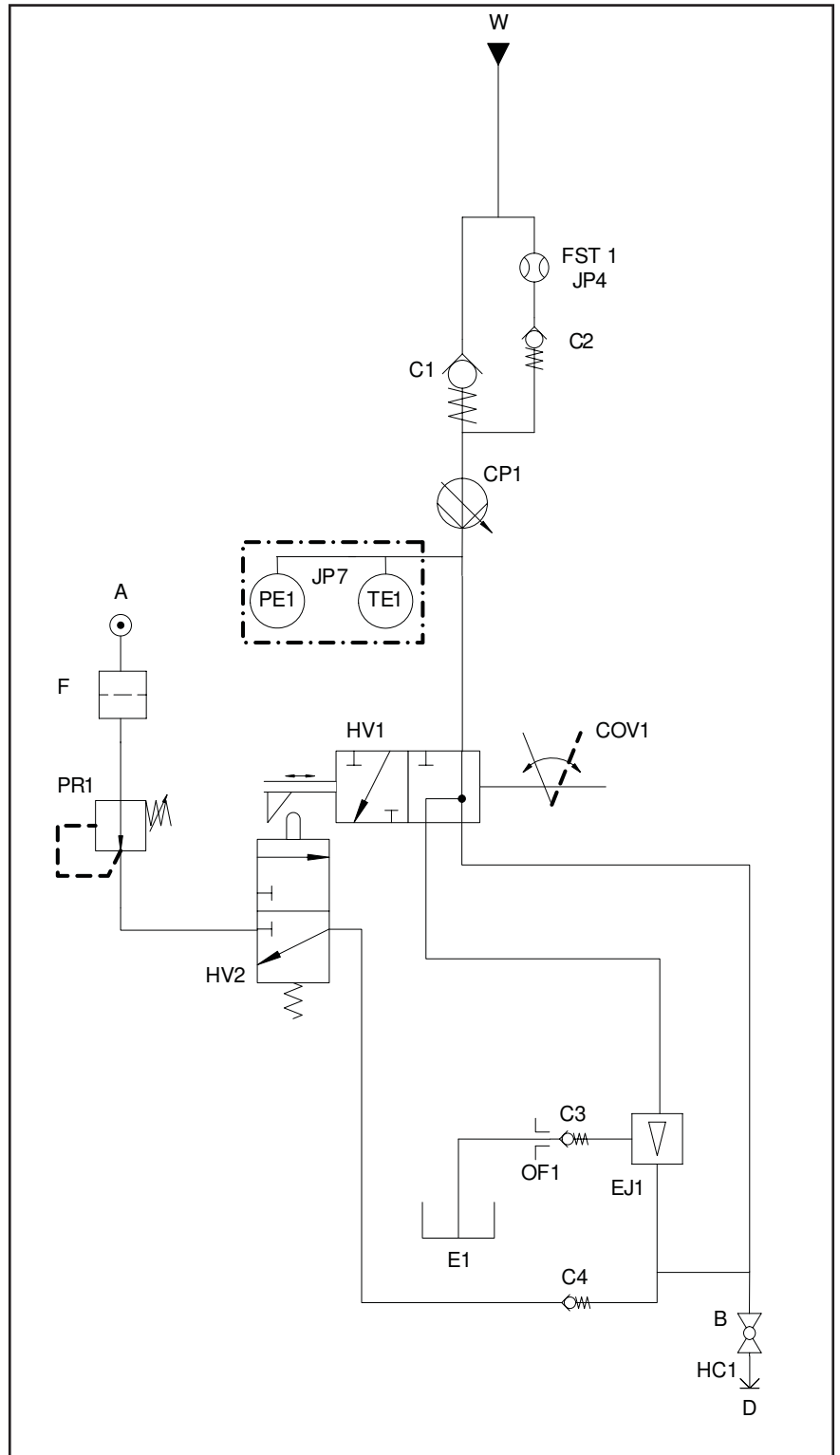

Fig. 6

0627145b

2. Maintenance

The main station is maintenance-free. However, filters must be cleaned at suitable intervals (approx. 1-3 months) depending on the content of impurities in the water.

2.1 Filter (Fig. 7)

1. Press "0" on the control panel to stop the main station.
2. Interrupt the master switch.
3. Close the water inlet.
4. Open a tap to release the system pressure.
5. Remove the filter (A) and place it in a descaling solution until the scale is dissolved.
6. Rinse the cleaned filter thoroughly and remount.

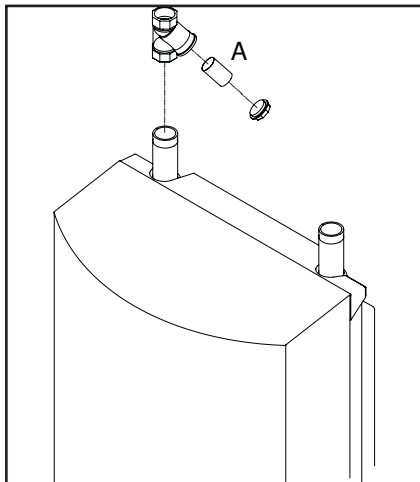

Fig. 7 0627117

2.2 Long stops

If long production stops are planned (more than 6 months) and the pump is emptied of water, it is recommended that the pump be secured as follows:

1. Remove the coupling safety guard.
2. Spray a couple of drops of silicone oil onto the axle between the top section and the coupling.

Carefully follow the instructions given in the manual provided by the pump supplier.

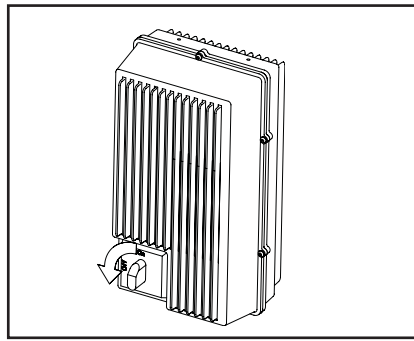

Fig. 8 0627106

3. Start

Note: The pump should be bled and filled with water before start.

3.1 New system

In order to ensure a problem-free start up of a new system the pipe system must be flushed and bled.

Bleeding the pipe system

1. Turn on the water supply to rinse and bleed the entire system. If satellites are installed open the tap furthest away until no air or dirt comes out. Then rinse and bleed the next tap and continue until the tap closest to you has been rinsed and bled.
2. Mount satellites, if any

Bleeding the pump

3. Loosen the relief plug (A, Fig 9) 1-2 revolutions until water and air begin to flow out.

Note: Never loosen the relief plug while the pump is running as this may damage the packing.

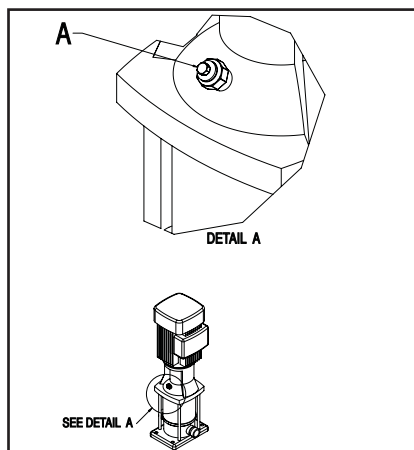

Fig. 9 0627131

4. Tighten the relief plug again
5. Start the pump so that all remaining air pockets are forced up to the top of the pump.
6. Stop the pump
7. Loosen the relief plug 1-2 revolutions again and bleed the system until only water flows out.
8. Tighten the relief plug once more

The main station is now ready for operation. Press "1" on the control panel. (see fig. 11)

4. Daily operation

4.1 Start

1. Check that water- and air supplies for the system are open. (see A, Fig.10,air)

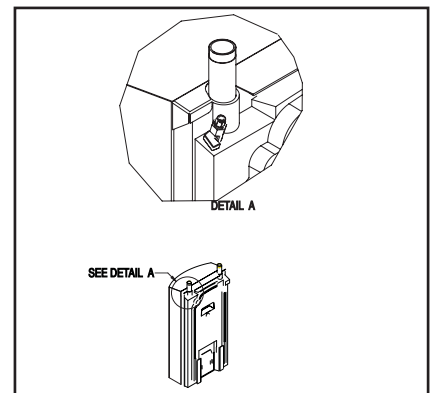

Fig. 10 0627123

2. Press "1" on the control panel to start.

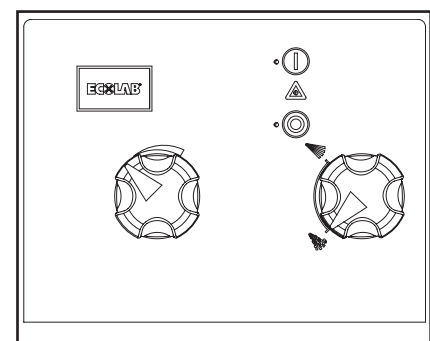

Fig. 11 0627119

4.2 Stop

1. Press "0" on the control panel to stop.
2. Turn off the water supply.
3. Close the air supply(A, Fig 10)

Note: It is important to shut off the water and air when the machine is left after use because:

- If the air supply is open when the main station and satellites are not in use, air may seep into the water pipe. If this is the case the system may have to be bled again.
- The water separator, which is a part of the air regulator, is only to be emptied when the air is shut off.

It may be necessary to bleed the pipes and the main station again after it has been closed for a longer period of time (holidays, and the like)

4.3 Rinsing the chemistry supply

IMPORTANT: The chemistry supply must always be rinsed thoroughly after use.

Remains of detergent or disinfectants can clog the chemistry supply so it needs to be rinsed or replaced. The following procedure will clean detergent and/or remains of disinfectants.

1. Remove User Pack, if any
2. Hold the rinsing bottle with clean water tightly against the suction opening (with User Pack) or against the hose (without User Pack). Alternatively, you can place a User Pack with clean water in the holder or – without User Pack – place the hose in a bucket of clean water.
3. Activate the hose handle until clean water comes out of the nozzle (approx. 30 seconds)

Note: This procedure should be followed for both the detergent and disinfectant side if this is installed.

5. Service

Service may only be carried out by authorized and qualified personnel.

Warning: The system must only be serviced when there is no voltage or pressure on the system.

1. Turn off the main switch at the control box
2. Open a water outlet to depressurise the system .

5.1 Components

5.1.1 Pumps/motor

Pumps/motor are maintenance free, see section 2.2

5.1.2 Control system

Maintenance free

If defective: Call a service technician

5.1.3 Flow trigger

Maintenance-free.

If defective, replace the flow switch.

Adjustments

1. Press "0" on the control panel to stop the system.
2. Turn the selector on the right side of the main station to foam position.
3. Open the right water outlet on the system, so water runs out, and make sure that there is no other consumption on the system.
4. Press "0" at the control panel in min. 10 sec. to zero set the flow trigger
5. The system is now in zero and is ready to start by pressing "I"

5.1.4 Non-return valve/intake side

Maintenance-free.

If defective, replace the non-return valve.

6. Troubleshooting

6.1 The unit does not start

Steps 1 - 6

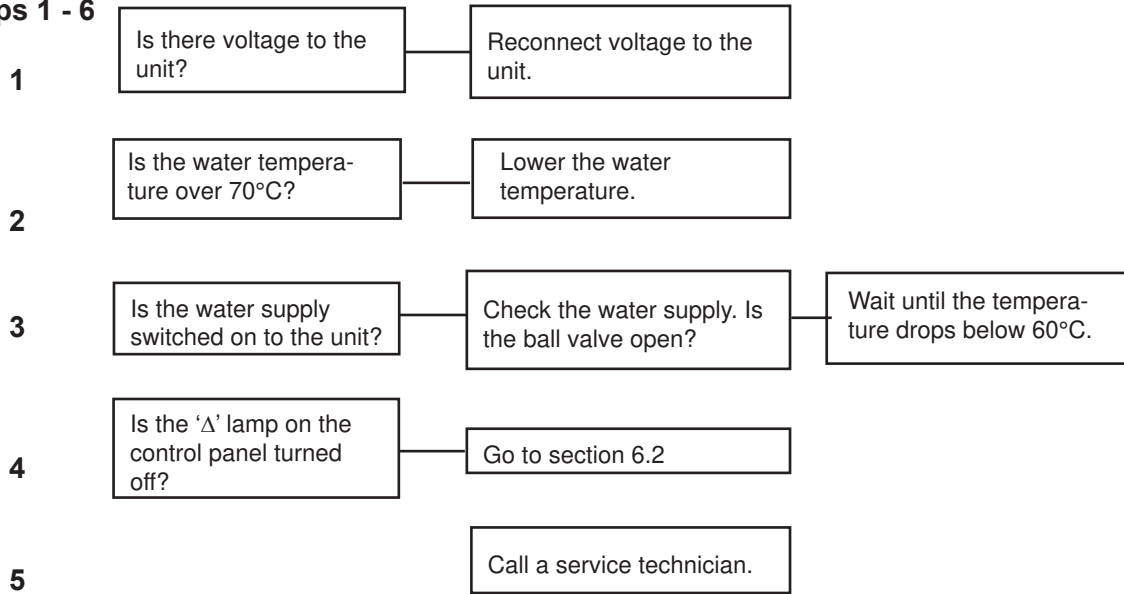

6.2 The "Δ" lamp on the control panel is on

Steps 1 - 5

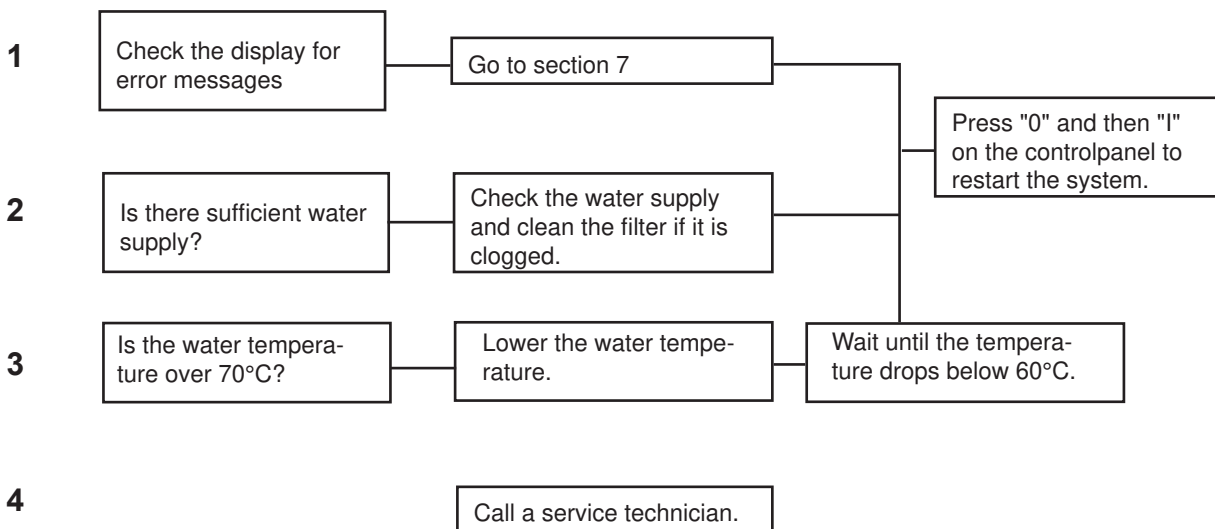

6.3 Too low or unstable pressure

Steps 1 - 4

1	Is there sufficient water supply?	Check that the inlet pressure is between 2 - 4 bars.
2	Is the filter clogged?	Clean the filter.
3	Is the pump leaking or does the pump make jarring sounds?	Call a service technician.
4		Call a service technician.

6.4 Unsatisfactory foam quality

Steps 1 - 4

1	Is the foam nozzle fitted?	Fit a 50/200 foam nozzle.
2	Is the air supply OK?	Adjust on the air regulator.
3	Is the detergent/disinfectant supply OK?	Adjust the supply on the dosage valve.
4		Call a service technician.

6.5 No foam

Steps 1 - 7

1	Is the switch in foam position?	Turn the switch to foam position.
2	Is the foam nozzle fitted?	Fit a 50/200 foam nozzle.
3	Is the dosage valve open?	Open the dosage valve.
4	Is the air supply connected?	Open the shut-off valve for air.
5	Is the filter in the hose from the detergent/disinfectant container clogged?	Clean or replace the filter
6	Is there detergent/disinfectant in the container?	Fill detergent/disinfectant in the container.
7		Call a service technician.

7. Recommended spare parts

Main stations

Nr.	Description	Amount
0603338	Non-return valve, pair, water-inlet	1
0631077	Trigger sensor	1
0631060	Pressure/temperature sensor	1
0646050	Non-return valve, chemistry	1
0664136	Non-return valve, air	1
0603339	Non-return valve, water	1

8.1 Connection of Controller board and mounting of sensor

Mains.
3/PE 320 V -0%...528 V +0%
48 Hz -0%...62 Hz +0%

Green/Yellow L1 L2 L3

Note: Phase sequence unimportant.
Earth leakage current > 30 mA
Pulse-current or universal-current
sensitive earth leakage circuit
breaker

Connecting cable.

87 Hz

V2 ○ ○ W1
U2 ○ ○ V1
W2 ○ ○ U1

Motor connection Δ (delta).
Connected as above.

Frequency inverter.

Controller board.

WARNING
Device is live up to 180s after removing mains voltage

Pin.	Connection.	Spec.	Note.	Cable colour.
1	Temperature signal	0.5 ... 3.5 V	Relative to pin 3	Yellow
2	Flow signal	0.36 ... 3.5 V	Relative to pin 3	White
2	Pressure signal	0.5 ... 3.5 V	Relative to pin 3	White
3	Ground	0		Green
4	Supply +	5 V DC		Brown

External I/O board
Display
Programming
Flow 1-20
Flow 15-300, suspended.
Flow 2-40
Pump top
Dry run
Fan
Motor temperature
Relay automatic block

PE

Observe the following when using E.I.c.b.:

- Installation of E.I.c.b. only between supplying mains and controller.
- The E.I.c.b. can be activated by:
 - capacitive leakage currents between the cable screens during operation (especially with long, screened motor cables)
 - connecting several controllers to the mains at the same time
 - RFI filters

Socket no.	Cable no.	Signal.	Niifisk-ALTO	
			Part no. on sensor	part no.
4	4	Dry run (0-4)	96500018	0631060
4	46	Dry run (0-16)	96577492	0631180
5	5	Pump top (0-25)	96655728	0631077
5	54	Pump top (0-40)	96621471	0631174
6	6	Flow 2-40	96579954	0631076
7	7	Flow 15-300	96656168	0631075
8	8	Flow 1-20	96650245	0631059
			96487933	
			96650805	

Used sensors:

	Professional	Advanced	Suspended
Professional			X
Advanced			X
Suspended		X	
Optional			X
Suspended			X
X			X

0601725-E

Niifisk-ALTO
Food Division.
Blytaekervej 2
DK-9000 Aalborg
Tel: +45 7218 2000 Fax: +45 7218 2099
www.niifiskfood.com

8. Specifications

The most important specifications are shown on the serial plates on the main station/satellite and pump, respectively.

Technical Data		MM1	MM3
Water	Unit.	3 (4 kW)	3 (4 kW)
Max. Outlet pressure.	bar	25	25
Consumption during rinsing.	L/min		
Consumption during foaming.	L/min		
Min. supply pressure.	bar	2	2
Max. supply pressure.	bar		
Min. water supply.	L/min	100	100
Pressure @ 90 [L/min]	bar	17	19,5
Pressure @ 120 [L/min]	bar		
Pressure @ 240 [L/min]	bar		
Flow @ 40 [bar]	L/min		
Max. water temp.	°C	70	70
Pipe dimension inlet Ø	inch	1.1/4"	1.1/4"
Pipe dimension outlet Ø	inch	1.1/4"	1.1/4"
Compressed air			
Min/Max air pressure.	bar	5-10	5-10
Compressed air consumption.	NL/min	200	200
Pipe dimension inlet Ø	mm	6	6
Electricity			
Supply voltage (V Hz)*	V	3/PE 400/480 V 320 -0%...528 +0%	3/PE 400/480 V 320 -0%...528 +0%
Frequency	Hz	50/60 Hz 48 -0%...62 +0%	50/60 Hz 48 -0%...62 +0%
Below @ 400 V mains input voltage:			
Motor load (kW)	kW	4	4
		Installation to EN 60204-1	
Nominal current	A	10.6	10.6
Fuse	A	16	16
L1, L2, L3, PE	mm ²	2.5	2.5
General			
No. Of chemical injectors		1 - 3	1 - 3
Chemical resistance			
Sound level ISO 11202	dB	Below 70	Below 70
Dimensions H x W x D	mm	785 x 550 x 375	785 x 550 x 375
Weight	kg	85	85

Printed in Denmark

No.: 0617618E 09/2008

© 2005 All rights reserved
Ecolab GmbH & Co. OHG
P.O. Box 13 04 06
D-40554 Düsseldorf
www.ecolab.com
Tel.: +49 211 98 93 203 - Fax: +49 211 98 93 223



Printed in Denmark