



Advanced satellite SP - SA series



Content EN

1. Description	3
1.1 Layout SP	4
1.2 Operating Diagrams SP	5
1.3 Layout SA	6
1.4 Operating Diagrams SA	7
2. Maintenance	8
3. Start	8
3.1 New System	8
4. Daily Operation	8
4.1 Start	8
4.2 Stop	8
4.3 Rinsing the Detergent supply	8
5. Service	8
5.1 Components	8
6. Trouble Shooting	9
7. Recommended Spare Parts	10
8. Specifications	10

1. Description

The satellite in the Chameleon range is a complete hygiene station which is connected to a booster or a main station. Therefore the satellite must be supplied with water in sufficient quantity, (power supply) compressed air, detergent(s) and disinfectant. The station is then ready for hygiene duties.

The Advanced satellite incorporates a unique pneumatically controlled valve system that ensures injectors are flushed with water between hygiene functions. Depending on the model the system can work automatically or pneumatically via the selector.

Important: Do not use the water from the system for applications other than cleaning.

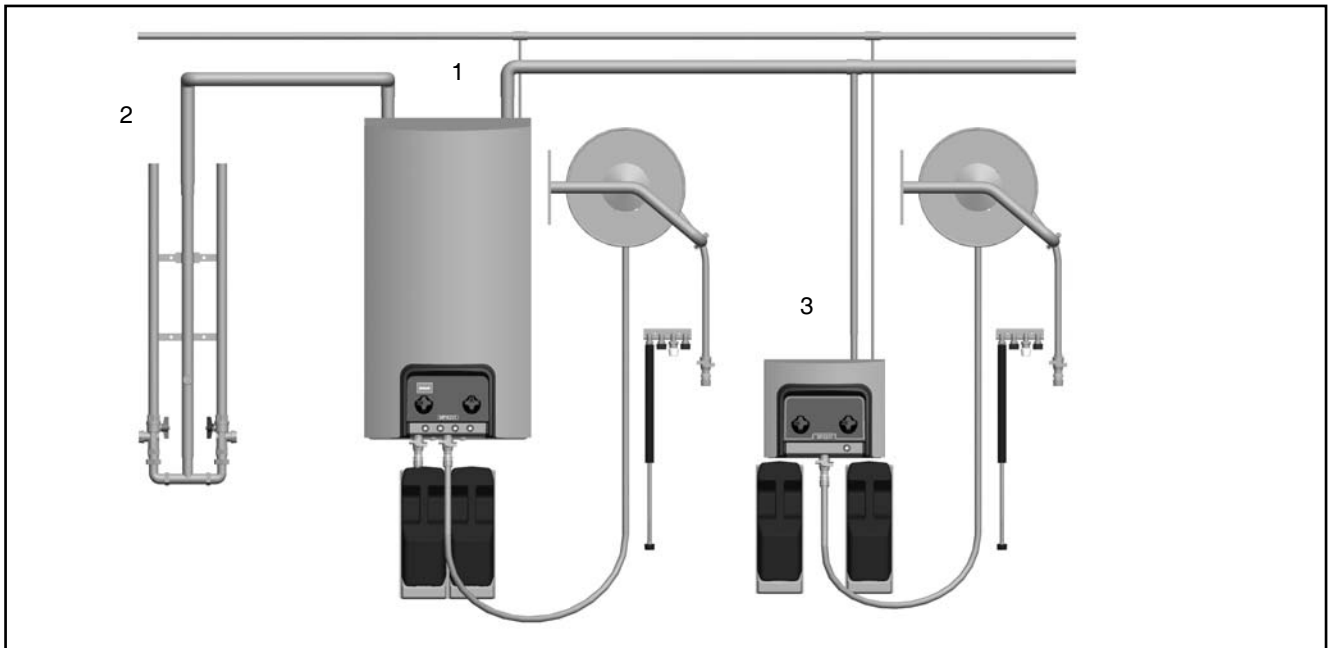

Fig. 1

0627103

Using hygiene Chemicals

The Advanced Satellite has been prepared to use Ecolabs European palette of detergents and disinfectants.

Warning: Do not change the settings made or recommended by the supplier of hygiene chemicals.

A typical installation of the Advanced series is shown in fig. 1

- Main station (1)
- Mixing system (2)
- Satellite (3)

Detergents are supplied either from the User Pack System, which can be ordered and delivered as an accessory or from separate standard cans. Hygiene chemicals can also be established through piping systems.

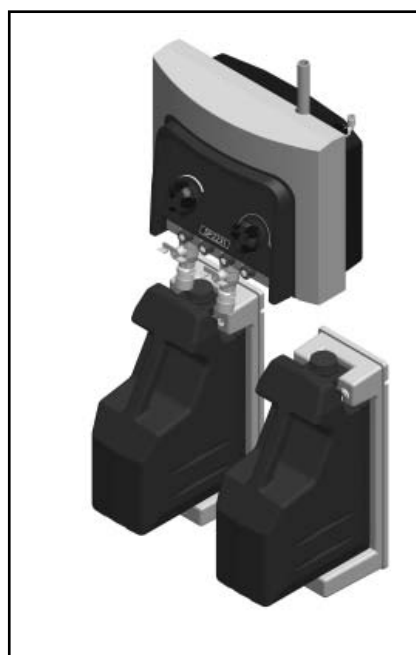

Fig. 2

0627088

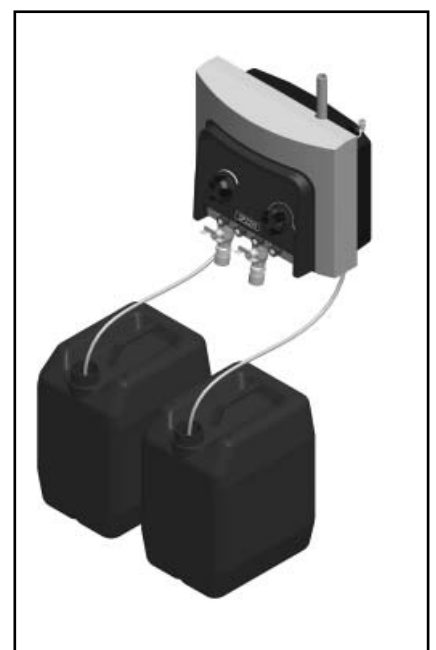

Fig. 3

0627127

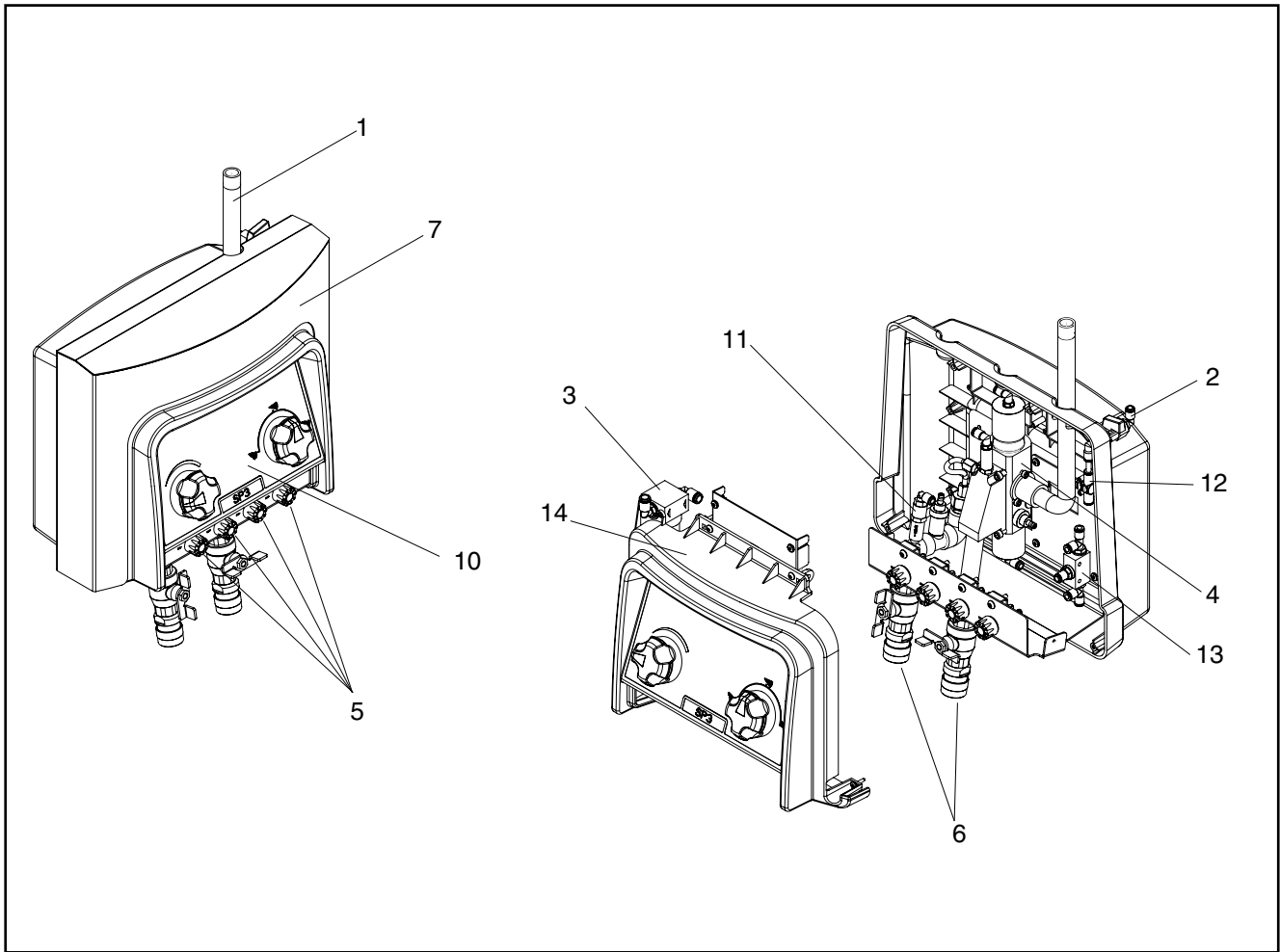

Fig. 4

0627136

1.1 Layout SP

Satellites

SP11-SP21-SP22-SP32-SP33 (Fig. 4).

1. Water inlet
2. Check valve, air
3. Air Filter unit
4. Injector block
5. Dosing valves
6. Quick coupling with check tap
7. Cover
8. Air regulator
9. Change-over switch, foam/rinse
10. Operational area
11. External Injector
12. Non Return valve, air
13. Change over valve
14. Operational panel

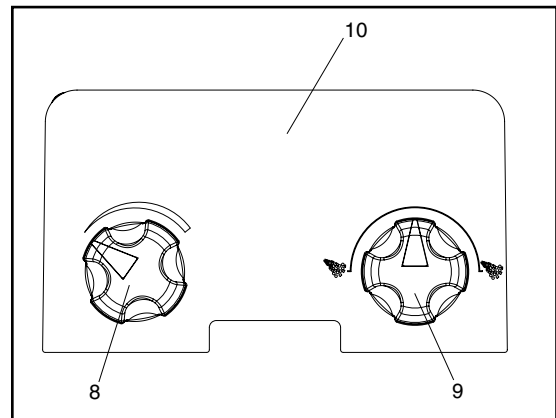

0627143

1.2 Operating Diagrams
iht. ISO14617
Satellite SP

- B. Ball valve.
- F. Filter.
- C. Check valve.
- CR. Detergent regulator.
- EJ. Ejector.
- HV. Hydraulic valve.
- HC. Hose connection.
- OV. Operator valve.
- OR. OR element.
- PR. Pressure regulator.
- A. Air supply.
- D. Outlet.
- E. Inlet, topax detergent.
- W. Water inlet.

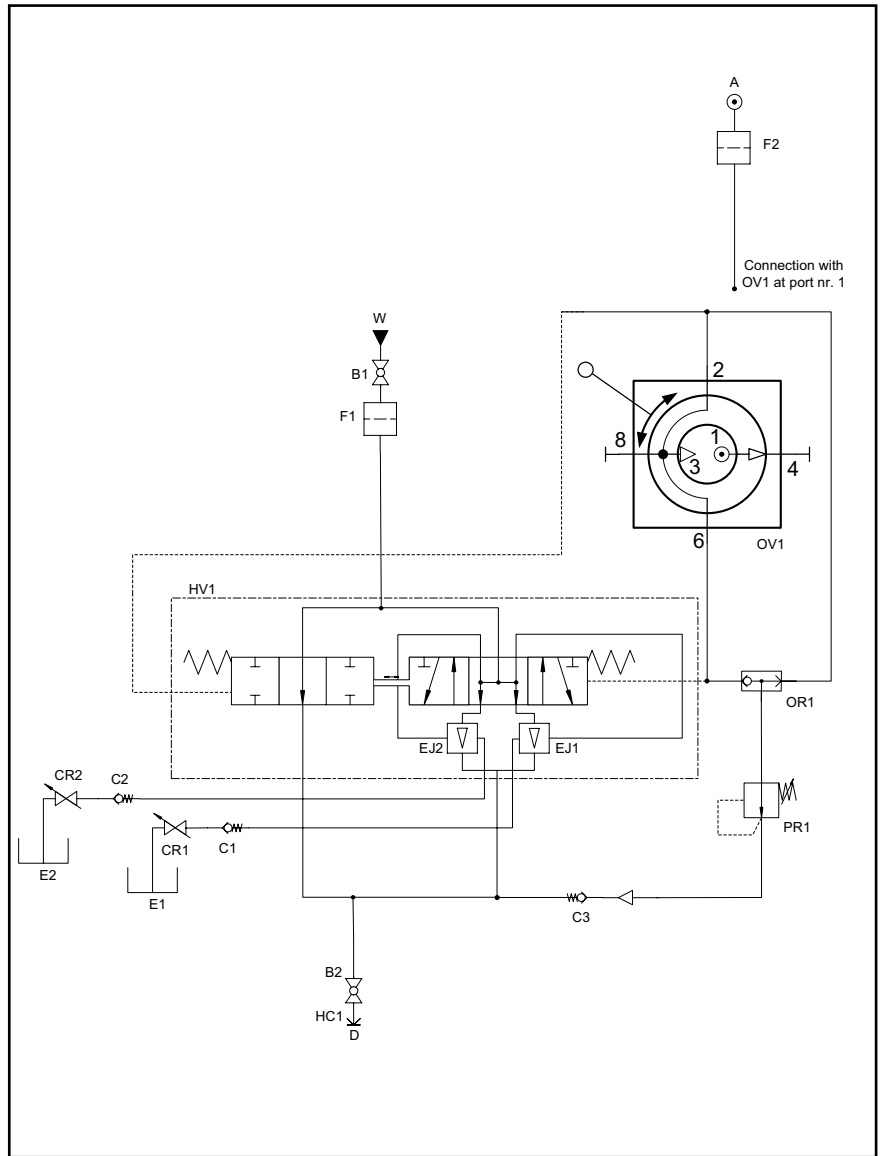

0627148

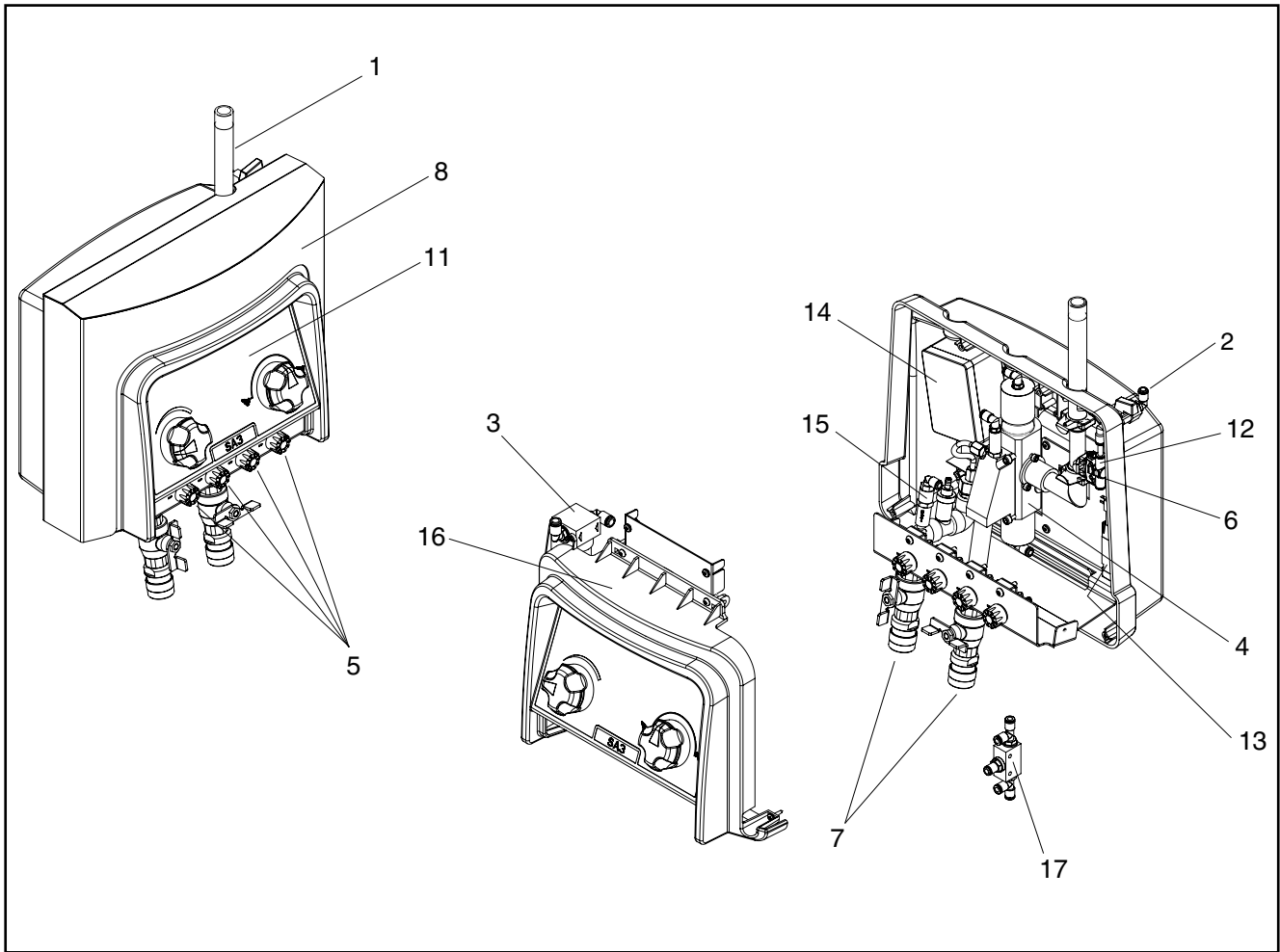

Fig. 4

0627137

1.3 Layout SA

Satellites

SA11-SA21-SA22-SA32-SA33(Fig. 4).

1. Water inlet
2. Check valve, air
3. Air Filter unit
4. Injector block
5. Dosing valve
6. Flow sensor
7. Quick coupling with check tap
8. Cover
9. Air regulator
10. Change-over switch, foam/rinse
11. Operational area
12. Non Return valve, air
13. Solenoid valve
14. Electrical Box
15. External Injector
16. Operation panel
17. Change over valve

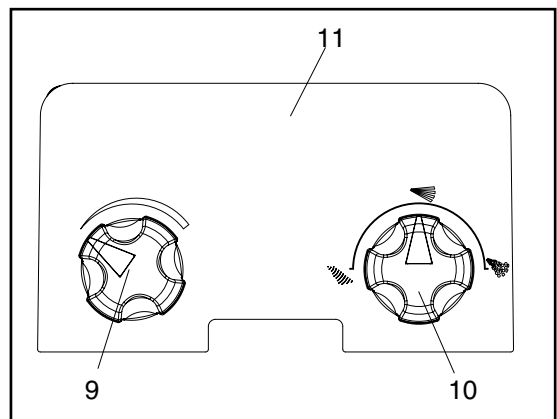

0627152

1.4 Operating Diagrams iht. ISO14617 Satellite SA

- B. Ball valve.
- F. Filter.
- FS. Flow sensor.
- C. Check valve.
- SV. Solenoid valve.
- CR. Chemistry regulator.
- EJ. Ejector.
- HV. Hydraulic valve.
- HC. Hose connection.
- OV. Operator valve.
- OR. OR element.
- PR. Pressure regulator.
- A. Air supply.
- D. Outlet.
- E. Inlet, Ecolab detergent.
- W. Water inlet.
- JPx : Control board connection.

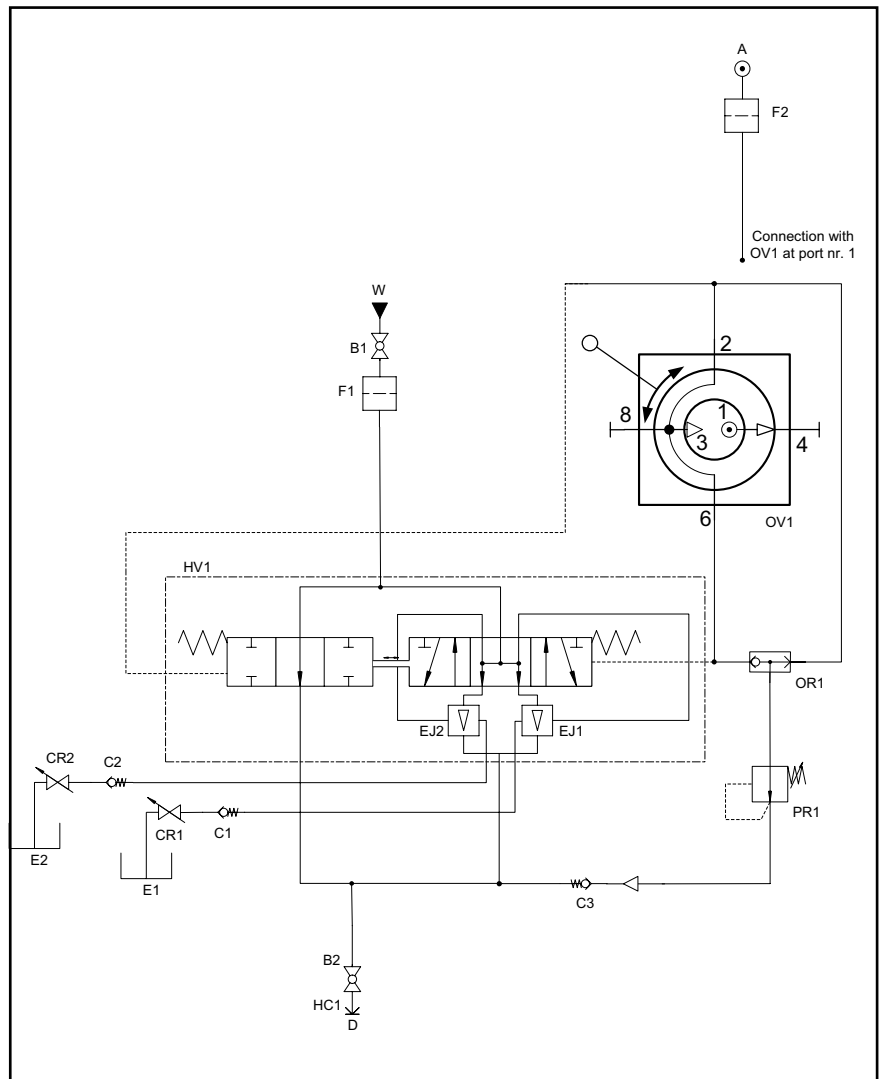

0627149

2. Maintenance

The satellite is maintenance-free.

3. Start

3.1 New system

In order to ensure a problem-free start up of a new system the pipe system must be flushed and bled.

Bleeding the pipe system

1. Turn on the water supply to rinse and bleed the entire system. Open the tap furthest away until no air or dirt comes out. Then rinse and bleed the next tap and continue until the tap closest to you has been rinsed and bled.
2. Mount satellites

4. Daily operation

4.1 Start

1. Check that water- and air supplies for the system are open.(see A, Fig.12, air)
2. Set the function that you want. Use the system referring to "User Guide" instructions

4.2 Stop

1. Close the water supply
2. Close the air supply(A, Fig 12)

Note: It is important to shut off the water and air when the machine is left after use because:

- If the air supply is open when the satellite is not in use, air may seep into the water pipe. If this is the case the system may have to be bled again.
- The water separator, which is a part of the air regulator, is only to be emptied when the air is shut off.

It may be necessary to bleed the pipes and the satellite again after it has been closed for a longer period of time (holidays, and the like)

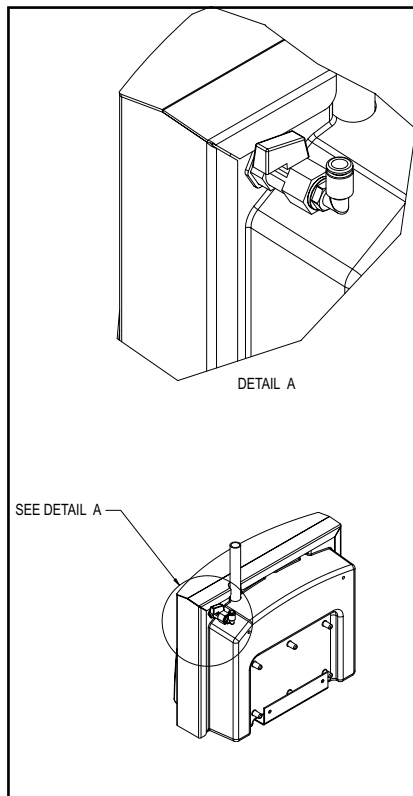

Fig. 12

0627132

4.3 Rinsing the detergent supply

IMPORTANT: The detergent supply must always be rinsed thoroughly after use. Remains of detergent or disinfectants can clog the detergent supply so it needs to be rinsed or replaced. The following procedure will clean the detergent supply for detergent and/or remains of disinfectants

1. Remove User Pack, if any
2. Hold the rinsing bottle with clean water tightly against the suction opening (with User Pack) or against the hose (without User Pack). Alternatively, you can place a User Pack with clean water in the holder or – without User Pack – place the hose in a bucket of clean water.
3. Activate the hose handle until clean water comes out of the nozzle (approx. 30 seconds).

Note: This procedure should be followed for both detergent and disinfectant side if this is installed.

5. Service

Service may only be carried out by authorized and qualified personnel.

Warning: The satellite must only be serviced when there is no pressure on the system.:

1. Turn off the water and air supply
2. Turn of the power supply
3. Depressurise the system.

5.1 Components

5.1.1 Non-return valve/inlet side (water, air, detergent)

Maintenance free

If defective: Call service technician

5.1.2 Flow trigger

Maintenance-free.

If defective, replace the flow trigger

Adjustments

1. Turn the selector reverser on the right side of the control panel to foam position. If the system is supplied with automatic block, this will happen.
2. Press "OK" on the control panel to open the menu.
3. Use the direction buttons to go to the menu:" Flow trigger" (you need a password – if you have no password, please contact "Service Centre" which is mentioned under Info).
4. Go to the menu "Flow trigger" and press "OK" to zero set
5. Open the right water outlet on the system, so water runs out and make sure, that there is no other consumption on the system (automatically zero set takes 10. sec.)
6. The system is now in zero and the menu can be left.

6. Troubleshooting

6.1 Too low or unstable pressure.

Steps 1 - 6

- 1

Is there sufficient water supply to the system?	Check the water supply.
---	-------------------------

- 2

Call a service technician

6.2 Unsatisfactory foam quality

Steps 1 - 4

- 1

Is the foam nozzle fitted?	Fit a 50/200 foam nozzle.
----------------------------	---------------------------
- 2

Is the air supply OK?	Adjust on the air regulator.
-----------------------	------------------------------
- 3

Is the detergent/disinfectant supply?	Adjust the supply on the dosage valve.
---------------------------------------	--
- 4

Call a service technician.

6.3 No foam

Steps 1 - 7

- 1

Is the switch in foam position?	Turn the switch to foam position.
---------------------------------	-----------------------------------
- 2

Is a foam nozzle fitted?	Fit a 50/200 foam nozzle.
--------------------------	---------------------------
- 3

Is the dosage valve open?	Open the dosage valve.
---------------------------	------------------------
- 4

Is the air supply connected?	Open the shut-off valve for air.
------------------------------	----------------------------------
- 5

Is the filter in the hose from the detergent/disinfectant container clogged?	Clean or replace the filter.
--	------------------------------
- 6

Is there detergent/disinfectant in the container?	Fill detergent/disinfectant in the container.
---	---
- 7

Call a service technician

7. Recommended spare parts

Satellite

Nr.	Description	Amount
0664136	Non-return valve, air	1
0646050	Non-return valve, detergent	1
0603338	Non-return valve, water	1

8. Specifications

The most important specifications are shown on the serial plates on the main station/satellite and pump, respectively.

Water	Unit	Adv.		
		Pneumatic SP	Automatic SA	
Max. outlet pressure.	bar	40	40	
Consumption during rinsing.	L/min	30	30	
Consumption during foaming.	L/min	10	10	
Min. supply pressure.	bar	12	12	
Max. supply pressure.	bar	40	40	
Min. water supply.	L/min	30	30	
Max. water temp.	°C	70	70	
Pipe dimension inlet Ø	inch	1/2"	1/2"	
Pipe dimension outlet Ø	inch	1/2"	1/2"	
Compressed air				
Min/Max air pressure	bar	5-10	5-10	
Compressed air consumption	NL/min	200	200	
Pipe dimension inlet Ø	mm	6	6	
General				
Dimensions	mm	330 x 403 x 215	330 x 403 x 215	330 x 403 x 215
Weight	kg	15	15	15
Electricity				
Supply voltage	V		1N/PE 110/230 V 85-0%...265+0%	24 V DC ± 10%
Frequency	Hz		50/60 Hz 48-0%...62+0%	
Power	W		3	

Printed in Denmark

No.: 0617609D 04/2007

© 2005 All rights reserved
Ecolab GmbH & Co. OHG
P.O. Box 13 04 06
D-40554 Düsseldorf
www.ecolab.com
Tel.: +49 211 98 93 203 - Fax: +49 211 98 93 223



Printed in Denmark