

# Professional Satellite Prediluted SM and SM-PD Series

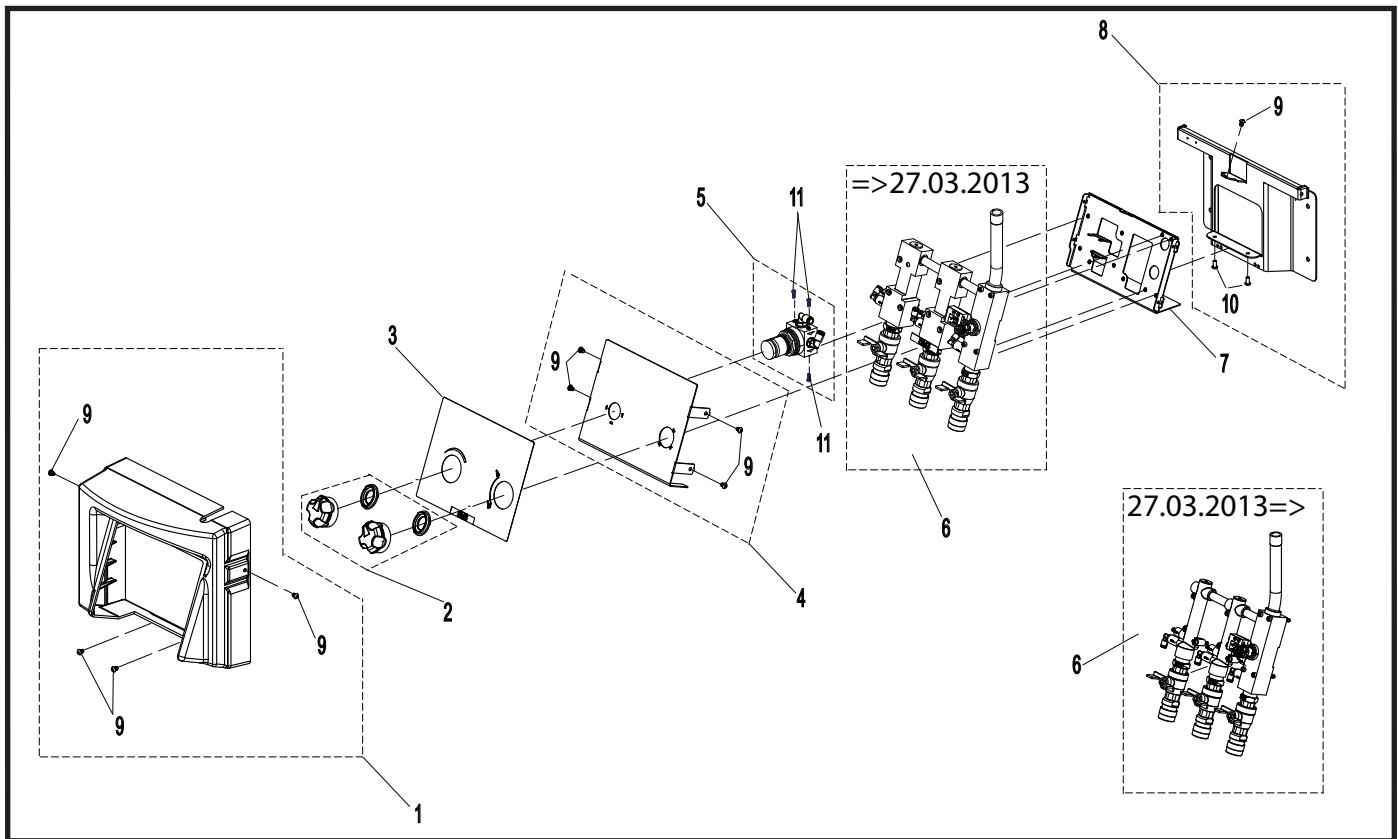

- Ⓔ EN Spare parts
- Ⓓ DE Ersatzteile
- Ⓕ FR Pièces détachées
- Ⓔ ES Repuestos
- Ⓓ DA Reservedele



1100001261

Pos. / Ref.	Nr. No.	Description Bezeichnung Désignation Denominación Betegnelse					
			SM11	SM21	SM22	SM32	SM33
1	110001213	Front Cover Frontcover Couvercle frontal Cubierta frontal Front cover	1	1	1	1	1
* 2	110001322	Handle Kit Bedienungshebel Set Kit de Poignée Kit de Asa Betjeningsgreb Kit	1	1	1	1	1
3	110001209	Label Kit Etiketete Set Kit de Etiquette Kit de Etiqueta Label Kit	1	1	1	1	1
4	110001210	Front Frame Frontrahmen Cadre frontal Marco frontal Front ramme	1	1	1	1	1
* 5	110001201	Regulation Unit, Air Luftregulierungseinheit Unité de contrôle de l'air Unidad de regulación del aire Luftstyringsenhed	1	1	1	1	1
6		Page 3 / 4 / 5 Seite 3 / 4 / 5 Page 3 / 4 / 5 Página 3 / 4 / 5 Side 3 / 4 / 5					
7	110001212	Rear Frame Hinterer Rahmen Cadre arrière Marco trasero Bagramme	1	1	1	1	1
8	110001215	Wall rack Wandhalter Ficacion murale Bastidor de montaje en pared Vægbeslag	1	1	1	1	1
▲ 9	110001200 (0602100)	Screw kit Schraube Set Kit de Vis Kit de Tornillo Skruer Kit					
▲ 10	110001200 (0602094)	Screw kit Schraube Set Kit de Vis Kit de Tornillo Skruer Kit					
▲ 11	110001200 (156114)	Screw kit Schraube Set Kit de Vis Kit de Tornillo Skruer Kit					

Pos. / Ref.	Nr. No.	Description Bezeichnung Désignation Denominación Betegnelse					
			SM11	SM21	SM22	SM32	SM33

2 \* Recommended spare parts / Empfehlenswerte Ersatzteile / Pièces de rechange conseillées / Piezas de repuesto recomendadas / Anbefalede Reservedele

▲ Min. order size is 10 pcs. / Min. Auftragsgröße ist 10 Stück / Le volume minimum de la commande est de 10 pièces. / El tamaño de pedido mínimo son 10 pcs. / Minimumssalg 10 stk

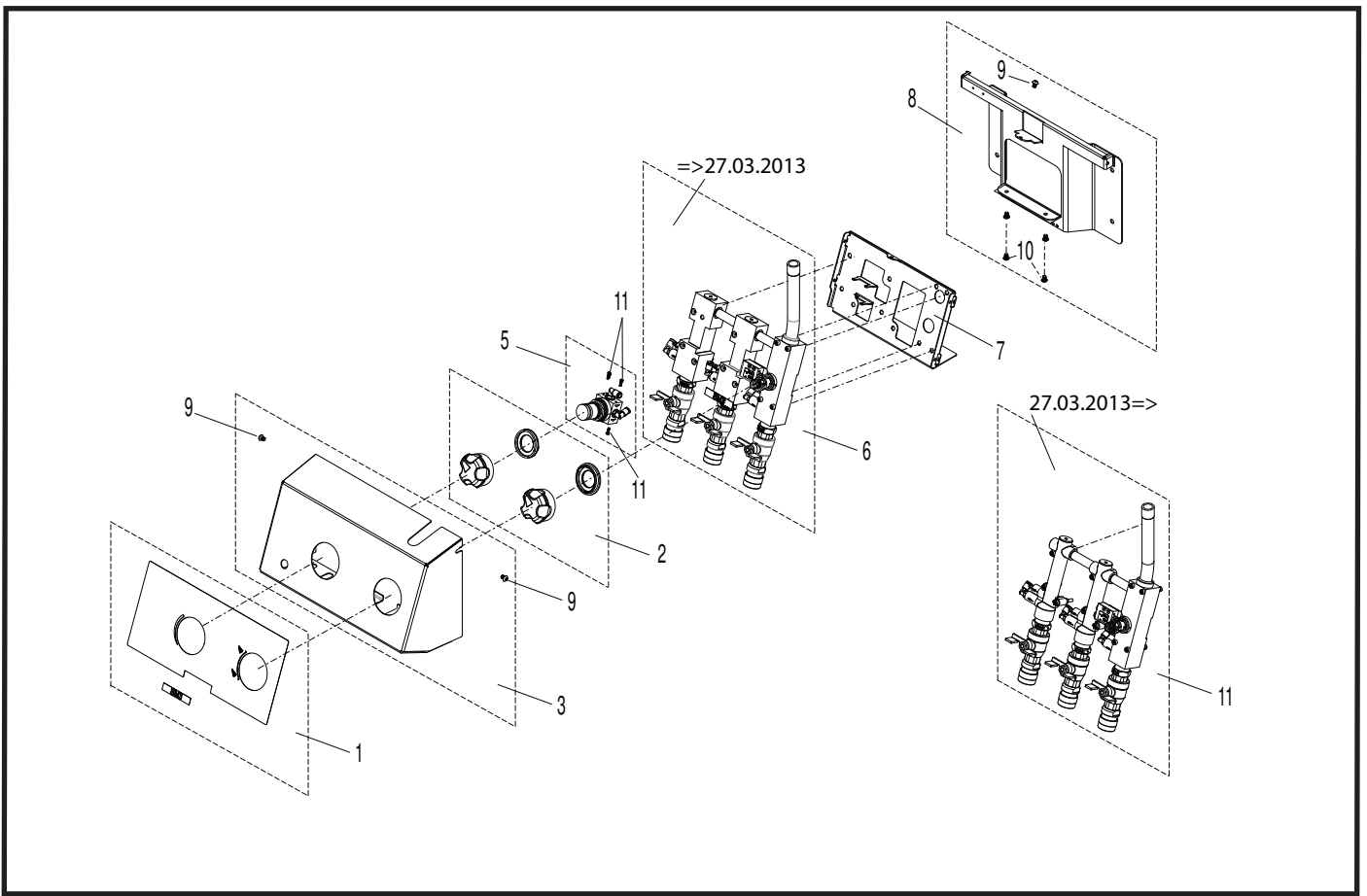

110002430

!	Pos. / Ref. Nr. No.	Description Bezeichnung Désignation Denominación Betegnelse	SM11	SM21	SM22	SM32	SM33
	1 110002436	Label Kit Etiketete Set Kit de <b>Etiquette</b> Kit de Etiqueta <b>Label Kit</b>	1	1	1	1	1
*	2 110001322	Handle Kit Bedienungshebel Set Kit de <b>Poignée</b> Kit de Asa <b>Betjeningsgreb Kit</b>	1	1	1	1	1
	3 110002435	Front Cover Frontcover <b>Couvercle frontal</b> Cubierta frontal <b>Front cover</b>	1	1	1	1	1
*	5 110001201	Regulation Unit, Air Luffregulierungseinheit <b>Unité de contrôle de l'air</b> Unidad de regulaci3n del aire <b>Lufftstyriingsenhed</b>	1	1	1	1	1
	6	Page 4 / 5 / 6 Seite 4 / 5 / 6 Page 4 / 5 / 6 P3gina 4 / 5 / 6 Side 4 / 5 / 6					
	7 110001212	Rear Frame Hinterer R3hmen <b>Cadre arri3re</b> Marco trasero <b>Bagramme</b>	1	1	1	1	1
	8 110001215	Wall rack Wandhalter <b>Ficaci3n murale</b> Bastidor de montaje en pared <b>Vægbeslag</b>	1	1	1	1	1
▲	9 110001200 (0602100)	Screw kit Schraube Set Kit de <b>Vis</b> Kit de Tornillo <b>Skrue Kit</b>					
▲	10 110001200 (0602094)	Screw kit Schraube Set Kit de <b>Vis</b> Kit de Tornillo <b>Skrue Kit</b>					
▲	11 110001200 (156114)	Screw kit Schraube Set Kit de <b>Vis</b> Kit de Tornillo <b>Skrue Kit</b>					

!	Pos. / Ref. Nr. No.	Description Bezeichnung Désignation Denominación Betegnelse	SM11	SM21	SM22	SM32	SM33

Professional Satellite Prediluted - 110001728D - 09/2013.

\* Recommended spare parts / Empfehlenswerte Ersatzteile / Pi3ces de rechange conseill3es / Piezas de repuesto recomendadas / Anbefalede Reservedele  
▲ Min. order size is 10 pcs. / Min. Auftragsgr33e ist 10 St3ck / Le volume minimum de la commande est de 10 pi3ces. / El tama3o de pedido m3nimo son 10 pcs. / Minimumssalg 10 stk

=>27.03.2013

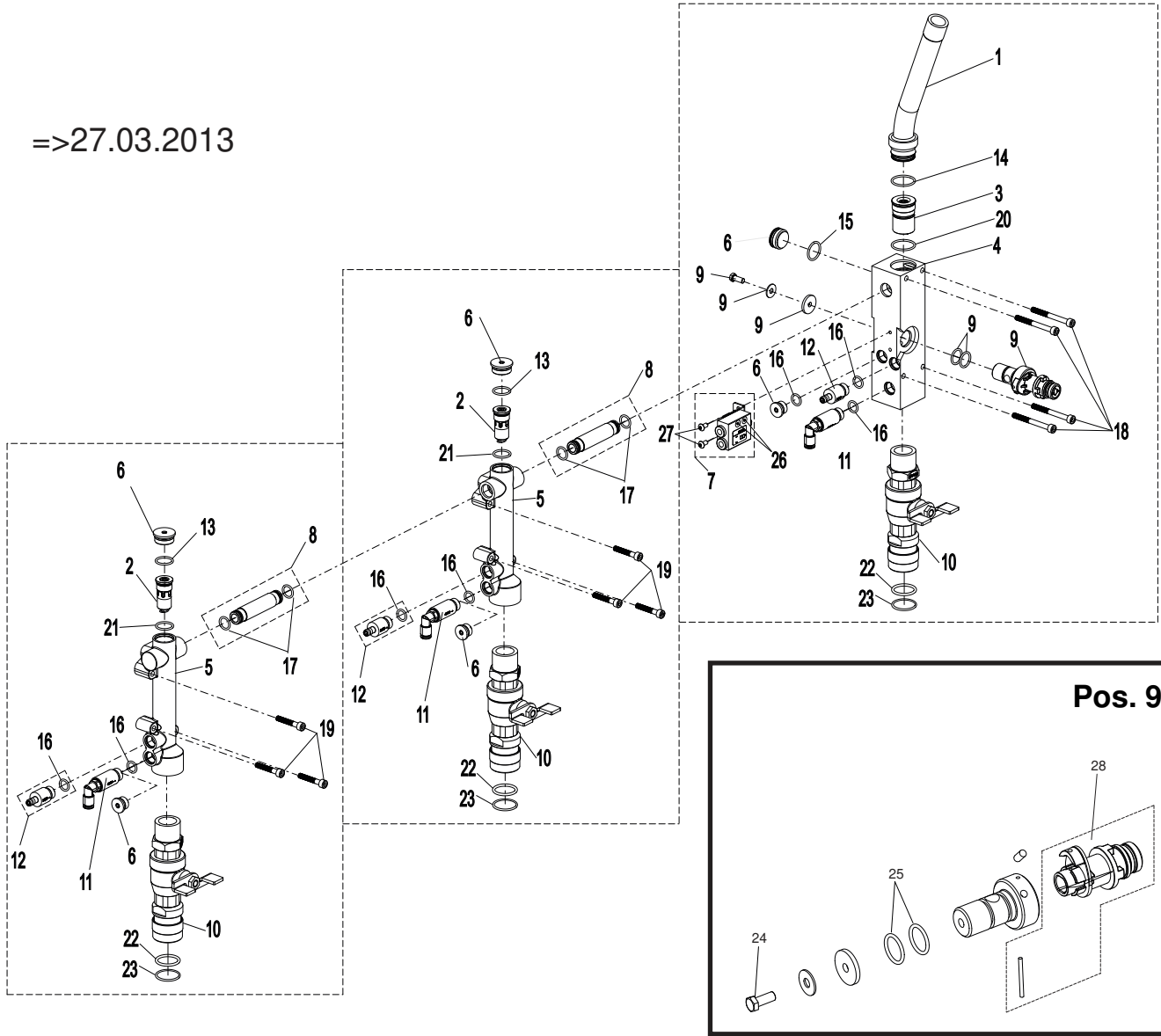

1100001262

1100001264

Pos. / Ref.	Nr. No.	Description Beschreibung Couvercle, unité principale Descripción Betegnelse	SM11	SM21	SM22	SM32	SM33
1	110001216	<b>Inlet Pipe</b> Einlassrohr <b>Conduit entrée</b> Tubería de alimentación <b>Tilgangsrør</b>	1	1	1	1	1
* 2	110001206	<b>Non Return Valve, water</b> Rückschlagventil, wasser <b>Clapet de retenue, eau</b> Válvula de retención, aqua <b>Vandkontraventil</b>		1	1	2	2
* 3	110001205	<b>Non Return Valve, water</b> Rückschlagventil, wasser <b>Clapet de retenue, eau</b> Válvula de retención, aqua <b>Vandkontraventil</b>	1	1	1	1	1
4		<b>Page 3</b> Seite 3 <b>Page 3</b> Página 3 <b>Side 3</b>					
5		<b>Page 3</b> Seite 3 <b>Page 3</b> Página 3 <b>Side 3</b>					
6	110001211	<b>Plug kit</b> Pfropfen Set <b>Kit de Bouchen</b> Kit de Tapón <b>Prop Kit</b>					
7	110001202	<b>Air Controlling Valve</b> Luftsteuerungsventil <b>Soupape de contrôle d'air</b> Válvula da regulación de aire <b>Luftstyringsventil</b>	1	1	1	1	1

Pos. / Ref.	Nr. No.	Description Beschreibung Couvercle, unité principale Descripción Betegnelse	SM11	SM21	SM22	SM32	SM33
8	110001317	<b>Connecting Pipe</b> Zwischen-/Verbindungsrohr1 <b>Conduit de connexion</b> Tubería de conexión <b>Mellemrør</b>		1	1	2	2
* 9	110001204	<b>Shaft complete</b> Welle Komplet <b>Arbre complet</b> Eje completo <b>Aksel Komplet</b>	1	1	1	1	1
10	110001208	<b>Outlet coupling complete</b> Ablaufkupplung komplett <b>Raccord de sortie complet</b> Acoplamiento de salida completo <b>Afgangskopling Komplet</b>	1	2	2	3	3
* 11	110001096	<b>Non Return Valve, air</b> Rückschlagventil, luft <b>Clapet de retenue, air</b> Válvula de retención de aire <b>Luftkontraventil</b>	1	1	2	2	3
* 12	110001102	<b>Non Return Valve, chemistry</b> Chemie Rückschlagventil, <b>Clapet anti-retour chimique</b> Válvula de no retorno química <b>Kemikontraventil</b>	1	2	2	3	3
▲ 13	110001207 (110000695)	<b>O-ring kit</b> O-ring Set <b>Kit de Joint torique</b> Kit de Aro tórico <b>O-rings Kit</b>					
▲ 14	110001207 (0600016)	<b>O-ring kit</b> O-ring Set <b>Kit de Joint torique</b> Kit de Aro tórico <b>O-rings Kit</b>					

! / Pos. / Ref.	Nr. No.	Description Bezeichnung Désignation Denominación Betegnelse	SMT1	SMT2	SMT3	SMT4	SMT5
▲ 15	110001207 (0635909)	O-ring kit O-ring Set Kit de Joint torique Kit de Aro tórico O-rings Kit					
▲ 16	110001207 (110000910)	O-ring kit O-ring Set Kit de Joint torique Kit de Aro tórico O-rings Kit					
▲ 17	110001207 (0635927)	O-ring kit O-ring Set Kit de Joint torique Kit de Aro tórico O-rings Kit					
▲ 18	110001200 (0602028)	Screw kit Schraube Set Kit de Vis Kit de Tornillo Skruer Kit					
▲ 19	110001200 (320100)	Screw kit Schraube Set Kit de Vis Kit de Tornillo Skruer Kit					
▲ 20	110001207 (0635910)	O-ring kit O-ring Set Kit de Joint torique Kit de Aro tórico O-rings Kit					
▲ 21	110001207 (0635912)	O-ring kit O-ring Set Kit de Joint torique Kit de Aro tórico O-rings Kit					
▲ 22	110001207 (641101)	O-ring kit O-ring Set Kit de Joint torique Kit de Aro tórico O-rings Kit					
▲ 23	110001207 (641102)	O-ring kit O-ring Set Kit de Joint torique Kit de Aro tórico O-rings Kit					
▲ 24	110001200 (156311)	Screw kit Schraube Set Kit de Vis Kit de Tornillo Skruer Kit					
▲ 25	110001207 (352800)	O-ring kit O-ring Set Kit de Joint torique Kit de Aro tórico O-rings Kit					
▲ 26	110001200 (110000525)	Screw kit Schraube Set Kit de Vis Kit de Tornillo Skruer Kit					
▲ 27	110001200 (0602021)	Screw kit Schraube Set Kit de Vis Kit de Tornillo Skruer Kit					
* 28	110000332	Stub shaft incl. pin Wellenansatz inkl. Splint Incl de demi-arbre, goupille Incl del eje corto, perno Akselforlænger med split					
▲ 27	110001200 (0602021)	Screw kit Schraube Set Kit de Vis Kit de Tornillo Skruer Kit					

! / Pos. / Ref.	Nr. No.	Description Bezeichnung Désignation Denominación Betegnelse	SMT1	SMT2	SMT3	SMT4	SMT5

\* Recommended spare parts / Empfehlenswerte Ersatzteile / Pièces de rechange conseillées / Piezas de repuesto recomendadas / Anbefalede Reserverdele  
▲ Min. order size is 10 pcs. / Min. Auftragsgröße ist 10 Stück / Le volume minimum de la commande est de 10 pièces. / El tamaño de pedido mínimo son 10 pcs. / Minimumssalg 10 stk

27.03.2013=>

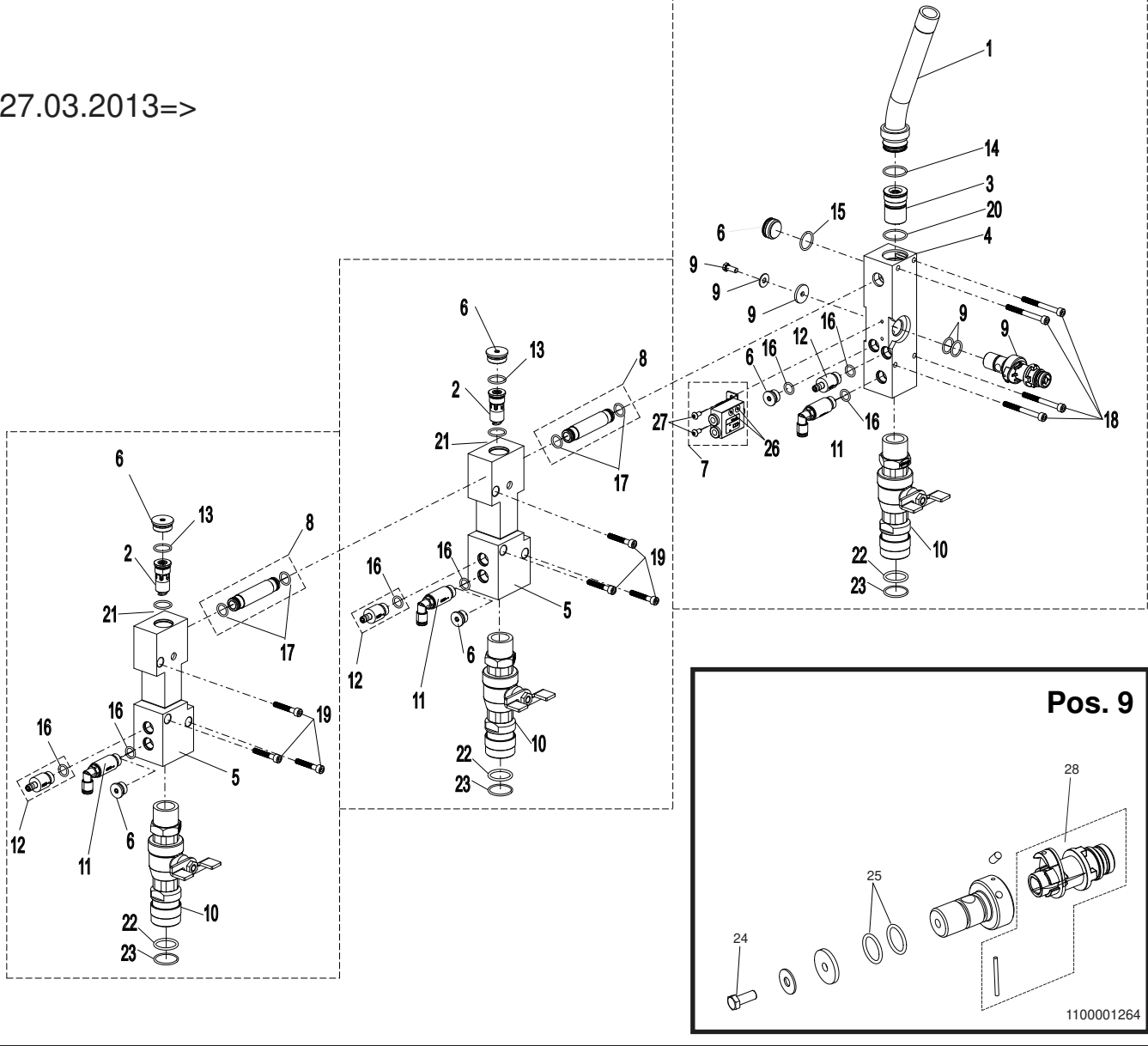

1100001262

Pos. / Ref.	Nr. No.	Description Beschreibung Couvercle, unité principale Descripción Betegnelse	SM11	SM21	SM22	SM32	SM33
1	110001216	<b>Inlet Pipe</b> Einlassrohr <b>Conduit entrée</b> Tuberia de alimentación <b>Tilgangsør</b>	1	1	1	1	1
* 2	110001206	<b>Non Return Valve, water</b> Rückschlagventil, wasser <b>Clapet de retenue, eau</b> Válvula de retención, agua <b>Vandkontraventil</b>		1	1	2	2
* 3	110001205	<b>Non Return Valve, water</b> Rückschlagventil, wasser <b>Clapet de retenue, eau</b> Válvula de retención, agua <b>Vandkontraventil</b>	1	1	1	1	1
4		<b>Page 3</b> Seite 3 <b>Page 3</b> Página 3 <b>Side 3</b>					
5		<b>Page 3</b> Seite 3 <b>Page 3</b> Página 3 <b>Side 3</b>					
6	110001211	<b>Plug kit</b> Pfropfen Set <b>Kit de Bouchen</b> Kit de Tapòn <b>Prop Kit</b>					
7	110001202	<b>Air Controlling Valve</b> Luftsteuerungsventil <b>Soupape de contrôle d'air</b> Válvula da regulación de aire <b>Luftstyringsventil</b>	1	1	1	1	1

Pos. / Ref.	Nr. No.	Description Beschreibung Couvercle, unité principale Descripción Betegnelse	SM11	SM21	SM22	SM32	SM33
8	110001317	<b>Connecting Pipe</b> Zwischen-/Verbindungsrohr1 <b>Conduit de connexion</b> Tuberia de conexión <b>Mellemrør</b>		1	1	2	2
* 9	110001204	<b>Shaft complete</b> Welle Komplett <b>Arbre complet</b> Eje completo <b>Aksel Komplet</b>	1	1	1	1	1
10	110001208	<b>Outlet coupling complete</b> Ablaufkupplung komplett <b>Raccord de sortie complet</b> Acoplamiento de salida completo <b>Afgangskopling Komplet</b>	1	2	2	3	3
* 11	110001096	<b>Non Return Valve, air</b> Rückschlagventil, luft <b>Clapet de retenue, air</b> Válvula de retención de aire <b>Luftkontraventil</b>	1	1	2	2	3
* 12	110001102	<b>Non Return Valve, chemistry</b> Chemie Rückschlagventil, <b>Clapet anti-retour chimique</b> Válvula de no retorno química <b>Kemikontraventil</b>	1	2	2	3	3
▲ 13	110001207 (110000695)	<b>O-ring kit</b> O-ring Set <b>Kit de Joint torique</b> Kit de Aro tórico <b>O-rings Kit</b>					
▲ 14	110001207 (0600016)	<b>O-ring kit</b> O-ring Set <b>Kit de Joint torique</b> Kit de Aro tórico <b>O-rings Kit</b>					

Pos. / Ref.	Nr. No.	Description Bezeichnung Désignation Denominación Betegnelse	SM11	SM21	SM22	SM32	SM33
▲ 15	110001207 (0635909)	O-ring kit O-ring Set <b>Kit de Joint torique</b> Kit de Aro tórico <b>O-rings Kit</b>					
▲ 16	110001207 (110000910)	O-ring kit O-ring Set <b>Kit de Joint torique</b> Kit de Aro tórico <b>O-rings Kit</b>					
▲ 17	110001207 (0635927)	O-ring kit O-ring Set <b>Kit de Joint torique</b> Kit de Aro tórico <b>O-rings Kit</b>					
▲ 18	110001200 (0602028)	Screw kit Schraube Set <b>Kit de Vis</b> Kit de Tornillo <b>Skruer Kit</b>					
▲ 19	110001200 (320100)	Screw kit Schraube Set <b>Kit de Vis</b> Kit de Tornillo <b>Skruer Kit</b>					
▲ 20	110001207 (0635910)	O-ring kit O-ring Set <b>Kit de Joint torique</b> Kit de Aro tórico <b>O-rings Kit</b>					
▲ 21	110001207 (0635912)	O-ring kit O-ring Set <b>Kit de Joint torique</b> Kit de Aro tórico <b>O-rings Kit</b>					
▲ 22	110001207 (641101)	O-ring kit O-ring Set <b>Kit de Joint torique</b> Kit de Aro tórico <b>O-rings Kit</b>					
▲ 23	110001207 (641102)	O-ring kit O-ring Set <b>Kit de Joint torique</b> Kit de Aro tórico <b>O-rings Kit</b>					
▲ 24	110001200 (156311)	Screw kit Schraube Set <b>Kit de Vis</b> Kit de Tornillo <b>Skruer Kit</b>					
▲ 25	110001207 (352800)	O-ring kit O-ring Set <b>Kit de Joint torique</b> Kit de Aro tórico <b>O-rings Kit</b>					
▲ 26	110001200 (110000525)	Screw kit Schraube Set <b>Kit de Vis</b> Kit de Tornillo <b>Skruer Kit</b>					
▲ 27	110001200 (0602021)	Screw kit Schraube Set <b>Kit de Vis</b> Kit de Tornillo <b>Skruer Kit</b>					
★ 28	110000332	Stub shaft incl. pin Wellenansatz inkl. Splint <b>Incl de demi-arbre. goupille</b> Incl del eje corto. perno <b>Akselforlænger med split</b>					
▲ 27	110001200 (0602021)	Screw kit Schraube Set <b>Kit de Vis</b> Kit de Tornillo <b>Skruer Kit</b>					

Pos. / Ref.	Nr. No.	Description Bezeichnung Désignation Denominación Betegnelse	SM11	SM21	SM22	SM32	SM33

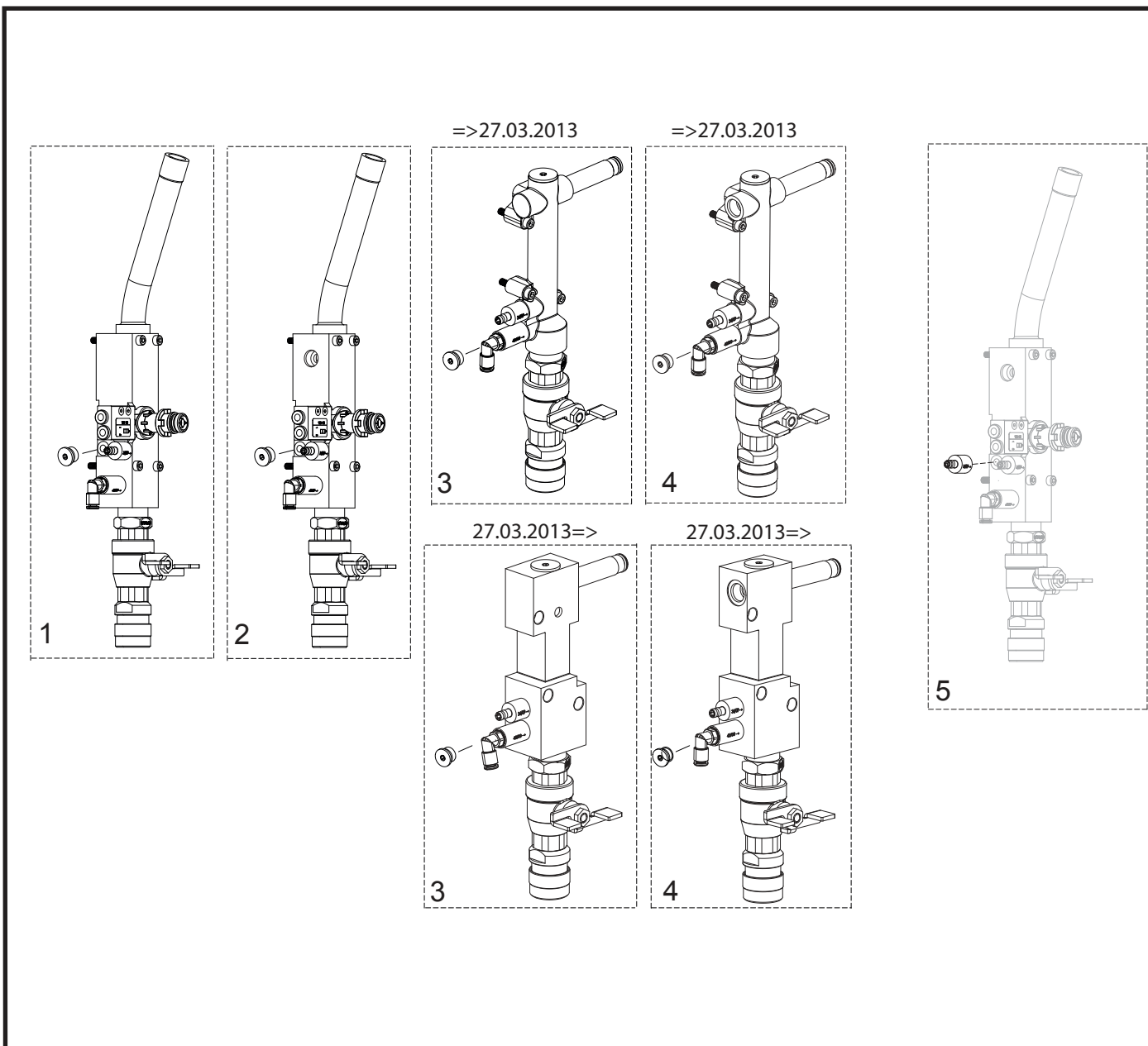

110001263

Pos. / Ref.	Nr. No.	Description Beschreibung Couvercle, unité principale Descripción Betegnelse	SM11	SM21	SM22	SM32	SM33
1	110001220	<b>Block complete</b> Block Komplett <b>Bloc, complet</b> Bloque, completo <b>Blok Komplet</b>	1				
2	110001221	<b>Block complete</b> Block Komplett <b>Bloc, complet</b> Bloque, completo <b>Blok Komplet</b>		1	1	1	1
3	110001226	<b>Block complete</b> Block Komplett <b>Bloc, complet</b> Bloque, completo <b>Blok Komplet</b>		1	1	1	1
4	110001227	<b>Block complete</b> Block Komplett <b>Bloc, complet</b> Bloque, completo <b>Blok Komplet</b>				1	1
5	110002289	<b>Suction kit for mix</b> Saugkitt f. mix <b>Kit aspirante pour mélange</b> Kit de succión <b>Sugekit for mix</b>					

Pos. / Ref.	Nr. No.	Description Beschreibung Couvercle, unité principale Descripción Betegnelse	SM11	SM21	SM22	SM32	SM33



SM-PD

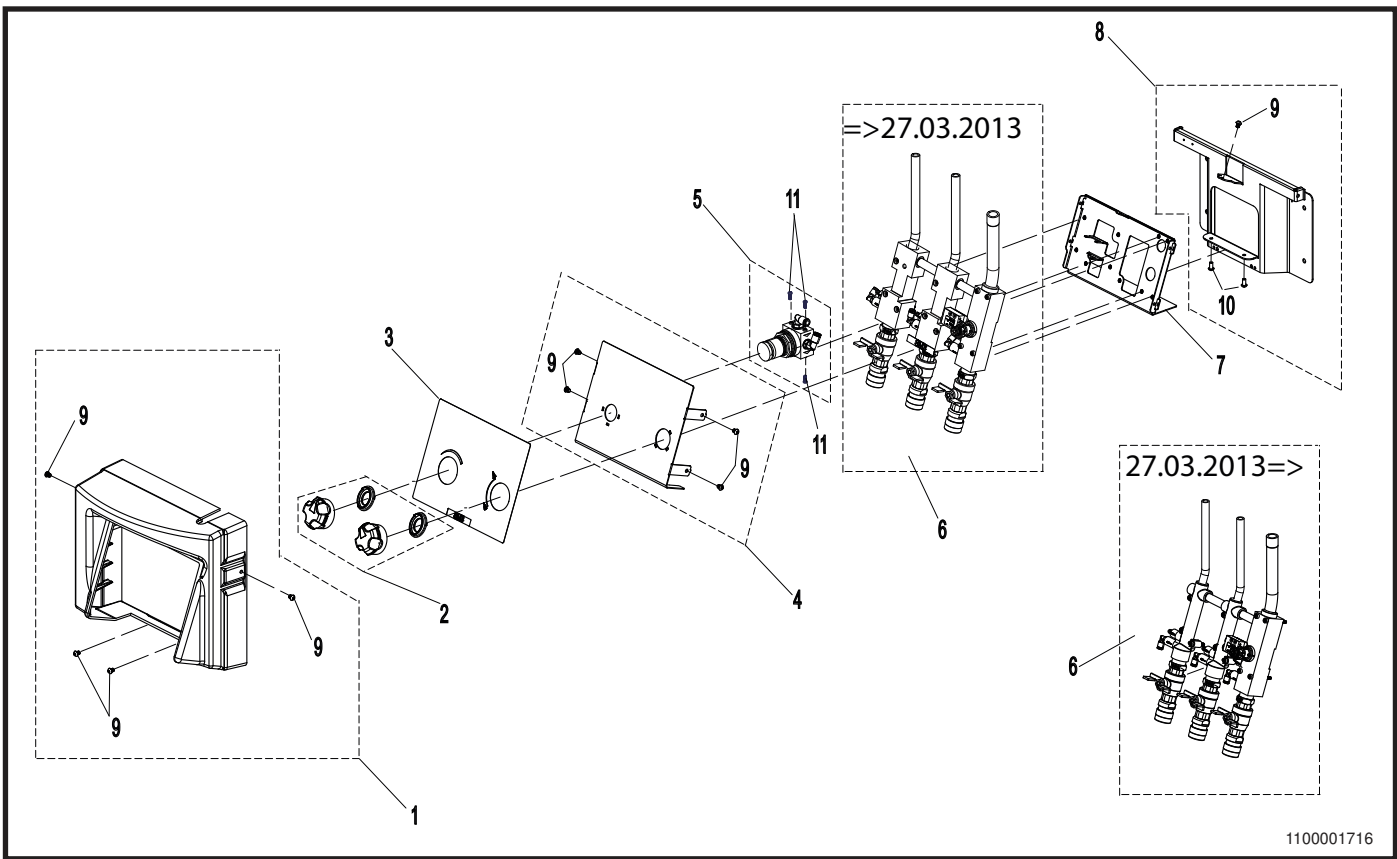

1100001716

Pos. / Ref.	Nr. No.	Description Bezeichnung Désignation Denominación Betegnelse				
			SM0-PD1	SM0-PD2	SM1-PD1	SM1-PD2
1	110001213	Front Cover Frontcover <b>Couvercle frontal</b> Cubierta frontal Front cover	1	1	1	1
★	2	Handle Kit Bedienungshebel Set Kit de <b>Poignée</b> Kit de Asa Betjeningsgreb Kit	1	1	1	1
3	110001209	Label Kit Etikette Set Kit de <b>Etiquette</b> Kit de Etiqueta Label Kit	1	1	1	1
4	110001210	Front Frame Frontrahmen <b>Cadre frontal</b> Marco frontal Front ramme	1	1	1	1
★	5	Regulation Unit, Air Luftregulierungseinheit <b>Unité de contrôle de l'air</b> Unidad de regulación del aire Luftstyringsenhed	1	1	1	1
6		Page 4 / 5 / 6 Seite 4 / 5 / 6 <b>Page 4 / 5 / 6</b> Página 4 / 5 / 6 Side 4 / 5 / 6				
7	110001212	Rear Frame Hinterer Rahmen <b>Cadre arrière</b> Marco trasero Bagramme	1	1	1	1
8	110001215	Wall rack Wandhalter <b>Ficaction murale</b> Bastidor de montaje en pared Vægbeslag	1	1	1	1
▲	9	Screw kit Schraube Set Kit de <b>Vis</b> Kit de Tornillo <b>Skrue Kit</b>				
▲	10	Screw kit Schraube Set Kit de <b>Vis</b> Kit de Tornillo <b>Skrue Kit</b>				
▲	11	Screw kit Schraube Set Kit de <b>Vis</b> Kit de Tornillo <b>Skrue Kit</b>				

Pos. / Ref.	Nr. No.	Description Bezeichnung Désignation Denominación Betegnelse				
			SM0-PD1	SM0-PD2	SM1-PD1	SM1-PD2

10\* Recommended spare parts / Empfehlenswerte Ersatzteile / Pièces de rechange conseillées / Piezas de repuesto recomendadas / Anbefalede Reservedele

▲ Min. order size is 10 pcs. / Min. Auftragsgröße ist 10 Stück / Le volume minimum de la commande est de 10 pièces. / El tamaño de pedido mínimo son 10 pcs / Minimumssalg 10 stk

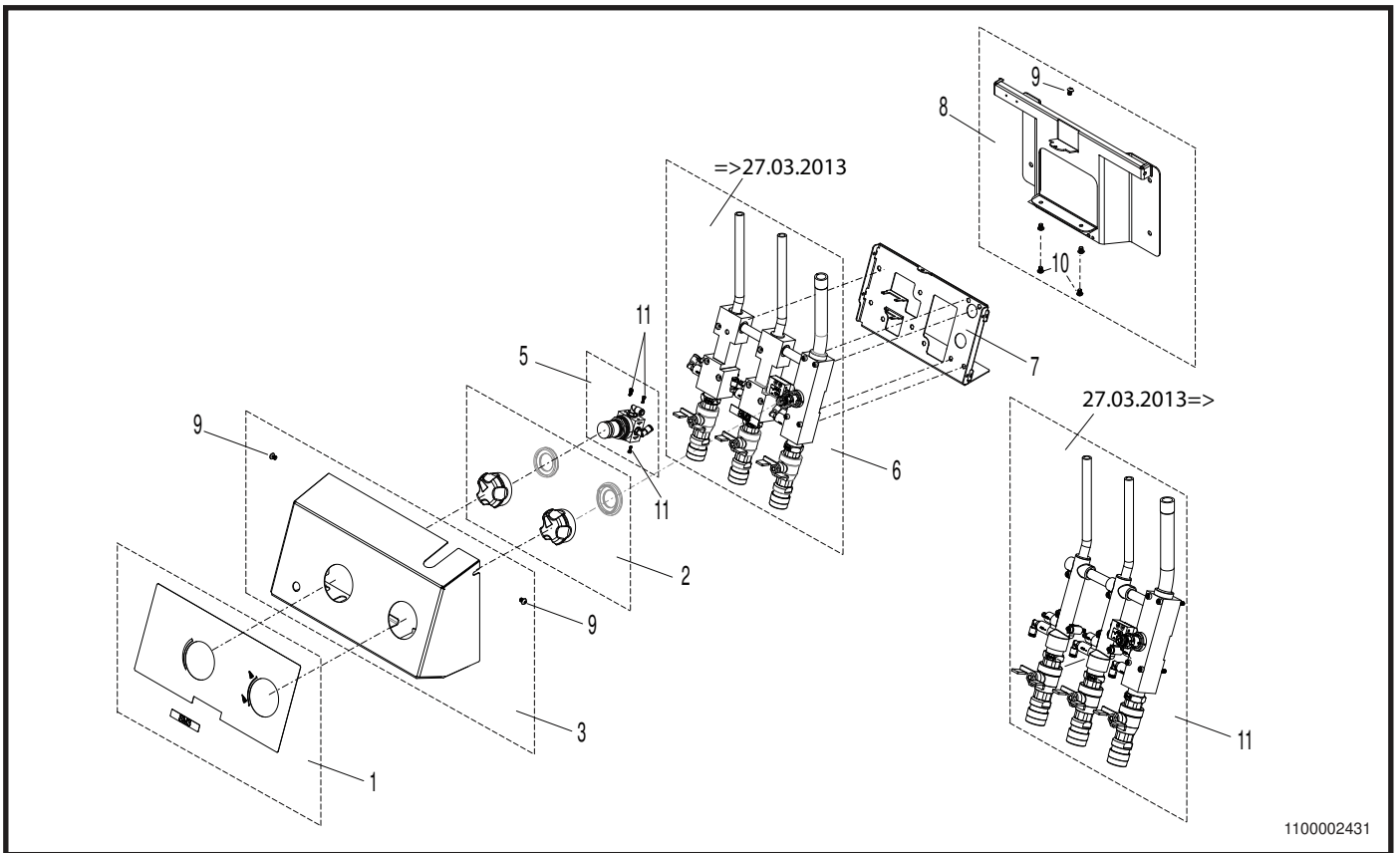

1100002431

!	Pos. / Ref. Nr.	Description Bezeichnung Désignation Denominación Betegnelse	SM0-PD1	SM0-PD2	SMT-PD1	SMT-PD2
	1	Label Kit Etikette Set Kit de <b>Etiquette</b> Kit de Etiqueta Label Kit	1	1	1	1
★	2	Handle Kit Bedienungshebel Set Kit de <b>Poignée</b> Kit de Asa Betjeningsgreb Kit	1	1	1	1
	3	Front Cover Frontcover <b>Couvercle frontal</b> Cubierta frontal Front cover	1	1	1	1
★	5	Regulation Unit, Air Luffregulierungseinheit <b>Unité de contrôle de l'air</b> Unidad de regulación del aire Luftstyringsenhed	1	1	1	1
	6	Page 4 / 5 / 6 Seite 4 / 5 / 6 <b>Page 4 / 5 / 6</b> Página 4 / 5 / 6 Side 4 / 5 / 6				
	7	Rear Frame Hinterer Rahmen <b>Cadre arrière</b> Marco trasero Bagramme	1	1	1	1
	8	Wall rack Wandhalter <b>Ficacion murale</b> Bastidor de montaje en pared Vægbeslag	1	1	1	1
	9	Screw kit Schraube Set Kit de <b>Vis</b> Kit de Tornillo <b>Skrue Kit</b>				
	10	Screw kit Schraube Set Kit de <b>Vis</b> Kit de Tornillo <b>Skrue Kit</b>				
▲	11	Screw kit Schraube Set Kit de <b>Vis</b> Kit de Tornillo <b>Skrue Kit</b>				

!	Pos. / Ref. Nr.	Description Bezeichnung Désignation Denominación Betegnelse	SM0-PD1	SM0-PD2	SMT-PD1	SMT-PD2

Professional Satellite Prediluted - 110001728D - 09/2013.

★ Recommended spare parts / Empfehlenswerte Ersatzteile / Pièces de rechange conseillées / Piezas de repuesto recomendadas / Anbefalede Reservedele  
▲ Min. order size is 10 pcs. / Min. Auftragsgröße ist 10 Stück / Le volume minimum de la commande est de 10 pièces. / El tamaño de pedido mínimo son 10 pcs. / Minimumssalg 10 stk

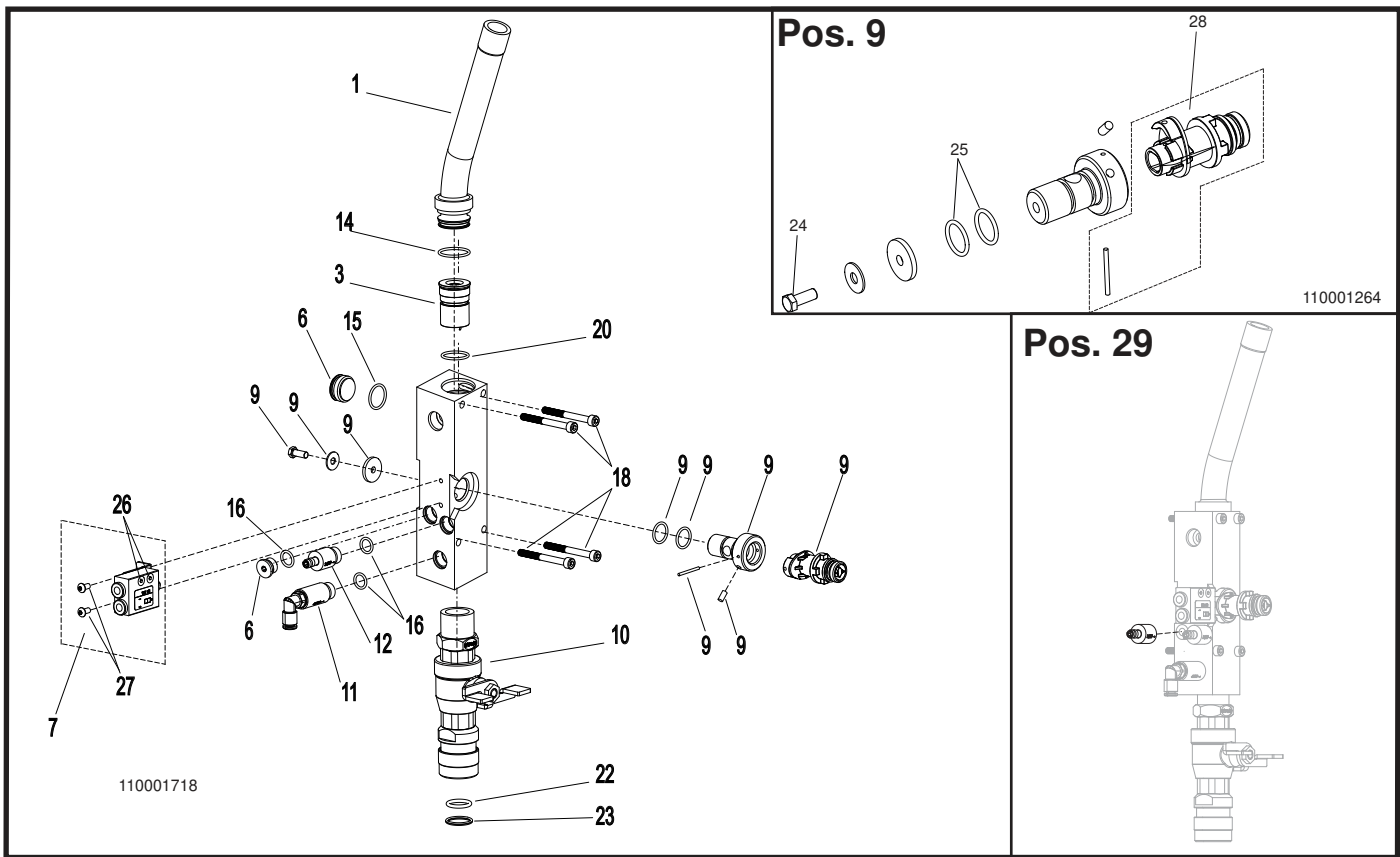

110001718

110001264

!	Pos. / Ref.	Nr. No.	Description Bezeichnung Désignation Denominación Betegnelse	SM0-PD1	SM0-PD2	SM1-PD1	SM1-PD2
	1	110001216	Inlet Pipe Einlassrohr Conduit entrée Tubería de alimentación Tilgangsør			1	1
*	3	110001205	Non Return Valve, water Rückschlagventil, wasser Clapet de retenue, eau Válvula de retención, aqua Vandkontraventil			1	1
	6	110001218	Plug kit Piropfen Set Kit de Bouchen Kit de Tapón Prop Kit				
	7	110001202	Air Controlling Valve Luftsteuerungsventil Soupape de contrôle d'air Válvula da regulación de aire Luftstyringsventil			1	1
*	9	110001204	Shaft complete Welle Komplett Arbre complet Eje completo Aksel Komplet			1	1
	10	110001208	Outlet coupling complete Ablaufkupplung komplett Raccord de sortie complet Acoplamiento de salida completo Afgangskopling Komplet			1	1
*	11	110001096	Non Return Valve, air Rückschlagventil, luft Clapet de retenue, air Válvula de retención de aire Luftkontraventil			1	1
*	12	110001102	Non Return Valve, chemistry Chemie Rückschlagventil Clapet anti-retour chimique Válvula de no retorno química Kemikontraventil			1	1
▲	14	110001207 (0600016)	O-ring kit O-ring Set Kit de Joint torique Kit de Aro tórico O-rings Kit				
▲	15	110001207 (0635909)	O-ring kit O-ring Set Kit de Joint torique Kit de Aro tórico O-rings Kit				
▲	16	110001207 (110000910)	O-ring kit O-ring Set Kit de Joint torique Kit de Aro tórico O-rings Kit				

!	Pos. / Ref.	Nr. No.	Description Bezeichnung Désignation Denominación Betegnelse	SM0-PD1	SM0-PD2	SM1-PD1	SM1-PD2
▲	18	110001200 (0602028)	Screw kit Schraube Set Kit de Vis Kit de Tornillo Skruer Kit				
▲	20	110001207 (0635910)	O-ring kit O-ring Set Kit de Joint torique Kit de Aro tórico O-rings Kit				
▲	22	110001207 (641101)	O-ring kit O-ring Set Kit de Joint torique Kit de Aro tórico O-rings Kit				
▲	23	110001207 (641102)	O-ring kit O-ring Set Kit de Joint torique Kit de Aro tórico O-rings Kit				
▲	24	110001200 (156311)	Screw kit Schraube Set Kit de Vis Kit de Tornillo Skruer Kit				
▲	25	110001207 (352800)	O-ring kit O-ring Set Kit de Joint torique Kit de Aro tórico O-rings Kit				
▲	26	110001200 (110000525)	Screw kit Schraube Set Kit de Vis Kit de Tornillo Skruer Kit				
▲	27	110001200 (0602021)	Screw kit Schraube Set Kit de Vis Kit de Tornillo Skruer Kit				
*	28	110000332	Shaft complete Welle Komplett Arbre complet Eje completo Aksel Komplet				
	29	110002289	Suction kit for mix Saugkitt f. mix Kit aspirante pour mélange Kit de succión Sugekit for mix				
		110001225	Block complete Block Komplett Bloc, complet Bloque, completo Blok Komplet			1	1

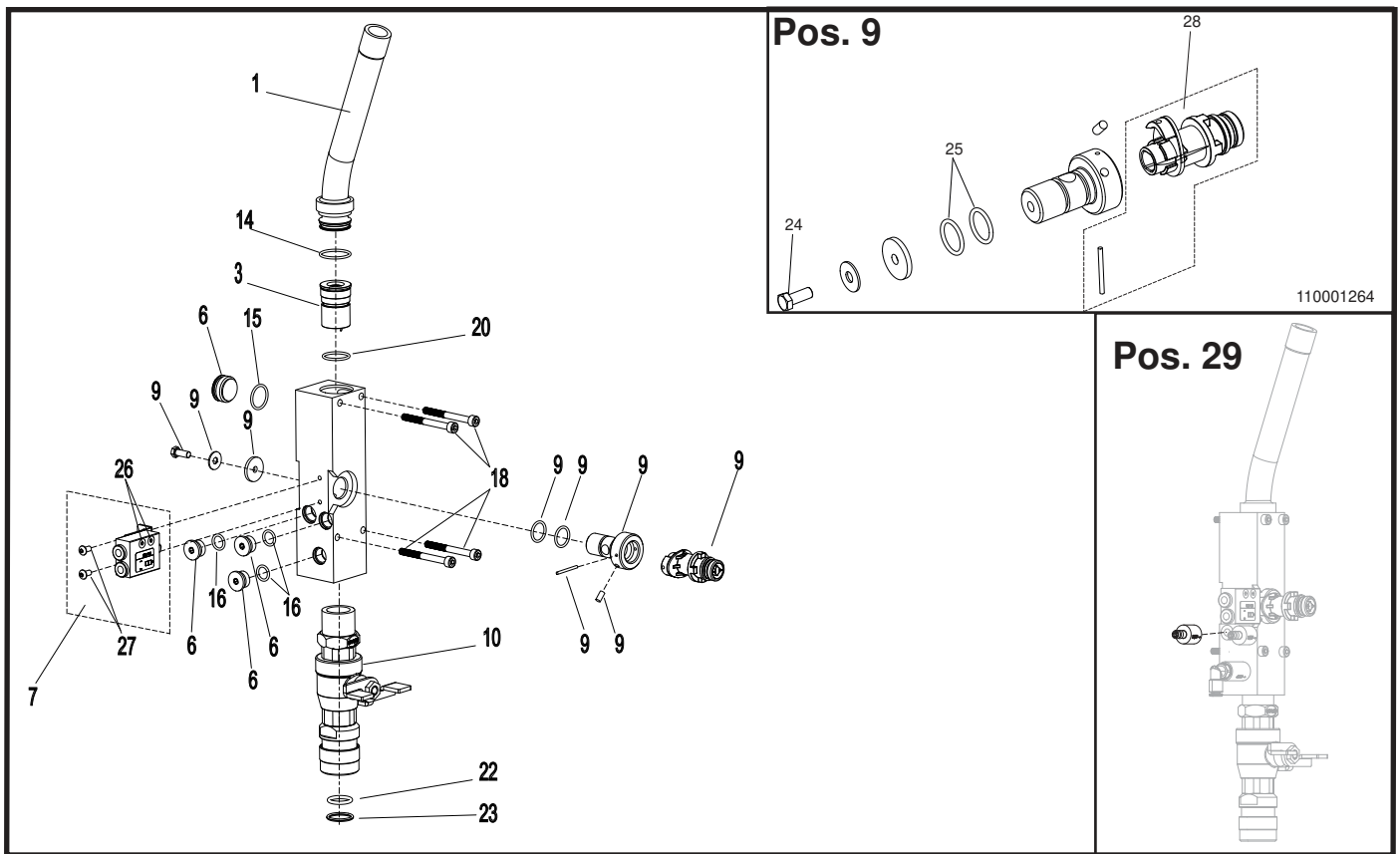

Pos. / Ref.	Nr. No.	Description Bezeichnung Désignation Denominación Betegnelse	SM0-PD1	SM0-PD2	SMT-PD1	SMT-PD2
1	110001216	Inlet Pipe Einlassrohr Conduit entrée Tuberia de alimentació Tilgangsror	1	1		
*	3	Non Return Valve, water Rückschlagventil, wasser Clapet de retenue, eau Válvula de retención, agua Vandkontraventil	1	1		
6	110001218	Plug kit Pfropfen Set Kit de Bouchen Kit de Tapòn Prop Kit				
7	110001202	Air Controlling Valve Luftsteuerungsventil Soupape de contrôle d'air Válvula da regulació de aire Luftstyringsventil	1	1		
*	9	Shaft complete Welle Komplett Arbre complet Eje completo Aksel Komplet	1	1		
10	110001208	Outlet coupling complete Ablaufkupplung komplett Raccord de sortie complet Acoplamiento de salida completo Afgangskopling Komplet	2	2		
▲	14	O-ring kit O-ring Set Kit de Joint torique Kit de Aro tórico O-rings Kit				
▲	15	O-ring kit O-ring Set Kit de Joint torique Kit de Aro tórico O-rings Kit				
▲	16	O-ring kit O-ring Set Kit de Joint torique Kit de Aro tórico O-rings Kit				
▲	18	Screw kit Schraube Set Kit de Vis Kit de Tornillo Skruer Kit				

Pos. / Ref.	Nr. No.	Description Bezeichnung Désignation Denominación Betegnelse	SM0-PD1	SM0-PD2	SMT-PD1	SMT-PD2
▲	20	O-ring kit O-ring Set Kit de Joint torique Kit de Aro tórico O-rings Kit				
▲	22	O-ring kit O-ring Set Kit de Joint torique Kit de Aro tórico O-rings Kit				
▲	23	O-ring kit O-ring Set Kit de Joint torique Kit de Aro tórico O-rings Kit				
▲	24	Screw kit Schraube Set Kit de Vis Kit de Tornillo Skruer Kit				
▲	25	O-ring kit O-ring Set Kit de Joint torique Kit de Aro tórico O-rings Kit				
▲	26	Screw kit Schraube Set Kit de Vis Kit de Tornillo Skruer Kit				
▲	27	Screw kit Schraube Set Kit de Vis Kit de Tornillo Skruer Kit				
*	28	Shaft complete Welle Komplett Arbre complet Eje completo Aksel Komplet				
	29	Suction kit for mix Saugkitt f. mix Kit aspirante pour mélange Kit de succión Sugekit for mix				
		Block complete Block Komplett Bloc, complet Bloque, completo Blok Komplet	1	1		

Professional Satellite Prediluted - 110001728D - 09/2013.

\* Recommended spare parts / Empfehlenswerte Ersatzteile / Pièces de rechange conseillées / Piezas de repuesto recomendadas / Anbefalede Reservedele

▲ Min. order size is 10 pcs. / Min. Auftragsgröße ist 10 Stück / Le volume minimum de la commande est de 10 pièces. / El tamaño de pedido mínimo son 10 pcs. / Minimumssalg 10 stk

=&gt;27.03.2013

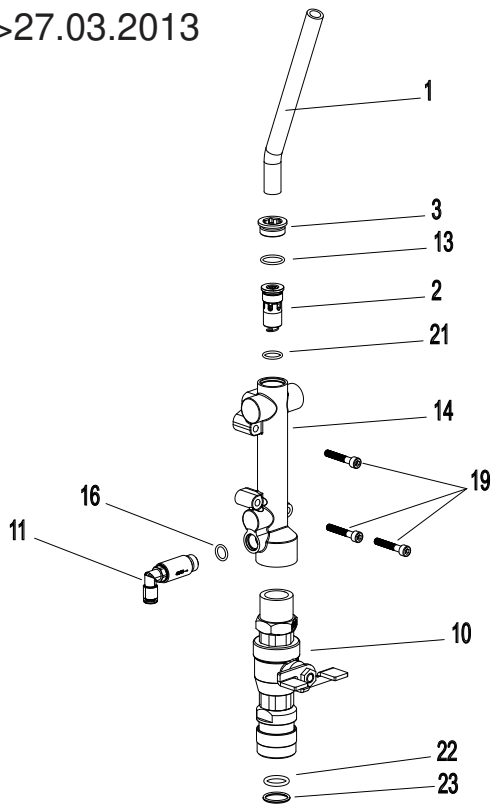

1100001719

27.03.2013=&gt;

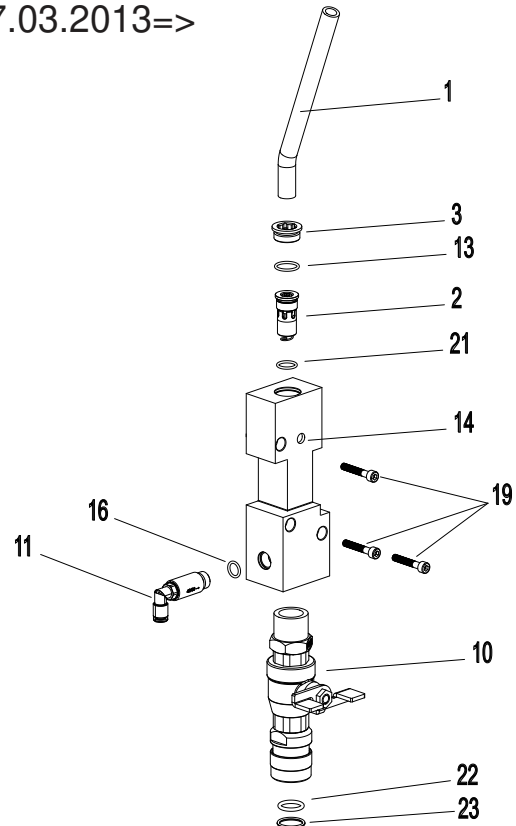

1100001587

!	Pos. / Ref.	Nr. No.	Description Bezeichnung Désignation Denominación Betegnelse				
				SM0-PD1	SM0-PD2	SM1-PD1	SM1-PD2
	1	110001217	Inlet Pipe Einlassrohr Conduit entrée Tubería de alimentación Tilgangsrør	1	2	1	2
*	2	110001206	Non Return Valve, water Rückschlagventil, wasser Clapet de retenue, eau Válvula de retención, aqua Vandkontraventil	1	2	1	2
	6	110001218	Plug kit Pfropfen Set Kit de Bouchen Kit de Tapón Prop Kit				
	10	110001208	Outlet coupling complete Ablaufkupplung komplett Raccord de sortie complet Acoplamiento de salida completo Afgangskopling Komplet	1	2	1	2
*	11	110001096	Non Return Valve, air Rückschlagventil, luft Clapet de retenue, air Válvula de retención de aire Luftkontraventil	1	1	1	1
▲	13	110001207 (110000695)	O-ring kit O-ring Set Kit de Joint torique Kit de Aro tórico O-rings Kit				
▲	16	110001207 (110000910)	O-ring kit O-ring Set Kit de Joint torique Kit de Aro tórico O-rings Kit				
▲	19	110001200 (320100)	Screw kit Schraube Set Kit de Vis Kit de Tornillo Skrue Kit				
▲	21	110001207 (0635912)	O-ring kit O-ring Set Kit de Joint torique Kit de Aro tórico O-rings Kit				
▲	22	110001207 (641101)	O-ring kit O-ring Set Kit de Joint torique Kit de Aro tórico O-rings Kit				
▲	23	110001207 (641102)	O-ring kit O-ring Set Kit de Joint torique Kit de Aro tórico O-rings Kit				

!	Pos. / Ref.	Nr. No.	Description Bezeichnung Désignation Denominación Betegnelse				
				SM0-PD1	SM0-PD2	SM1-PD1	SM1-PD2
		110001228	Block complete Block Komplet Bloc, complet Bloque, completo Bløk Komplet	1	2	1	2

14\* Recommended spare parts / Empfehlenswerte Ersatzteile / Pièces de rechange conseillées / Piezas de repuesto recomendadas / Anbefalede Reservedele

▲ Min. order size is 10 pcs. / Min. Auftragsgröße ist 10 Stück / Le volume minimum de la commande est de 10 pièces. / El tamaño de pedido mínimo son 10 pcs. / Minimumssalg 10 stk



Printed in Denmark

No.: 110001728D 09/2013

© 2013 All rights reserved  
ECOLAB Engineering GmbH,  
F & B Engineering Competence Centre EMEA,  
Raiffeisenstraße 7, D-83313 Siegsdorf  
Telephone.: (+49) 86 62 /61 0 - Fax: (+49) 86 62 / 61 2 35  
e-Mail: [engineering-mailbox@ecolab.com](mailto:engineering-mailbox@ecolab.com)

**ECOLAB<sup>®</sup>**