

Recommended spare parts
Empfehlenswerte Ersatzteile
Pièces de rechange conseiées
Piezas de requesto recomendadas

Cerberus

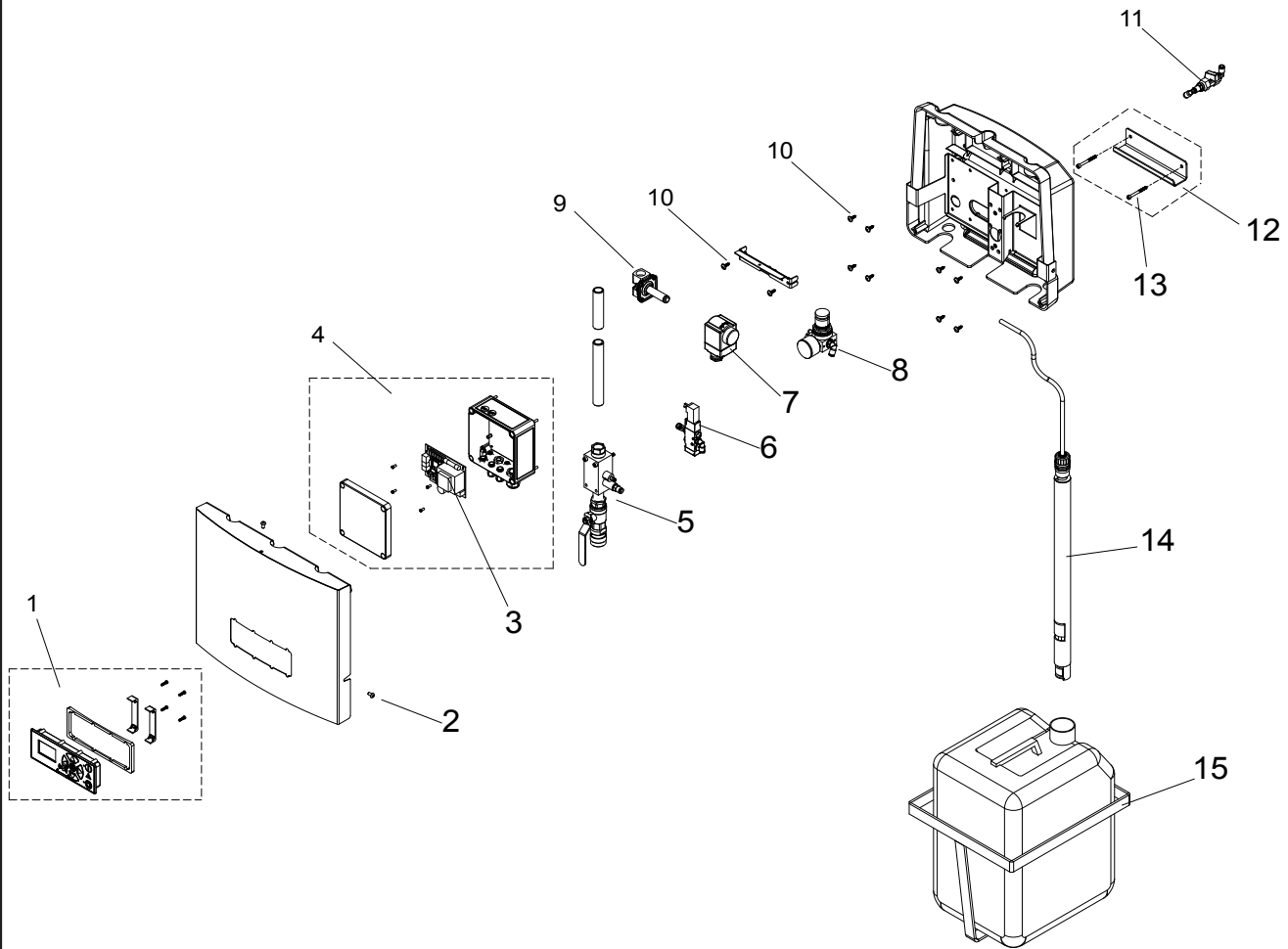

110003770

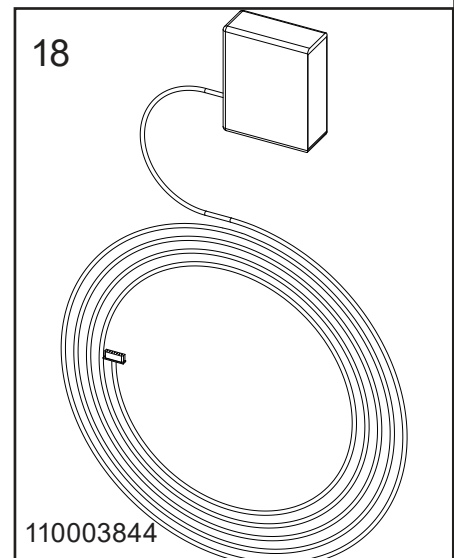
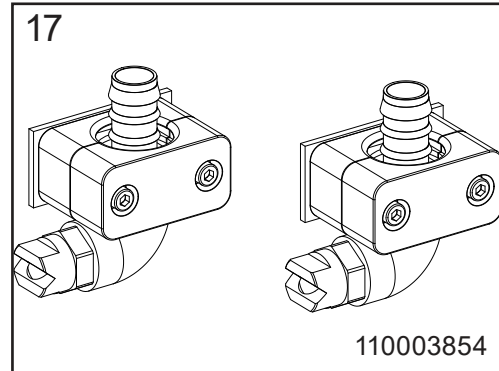
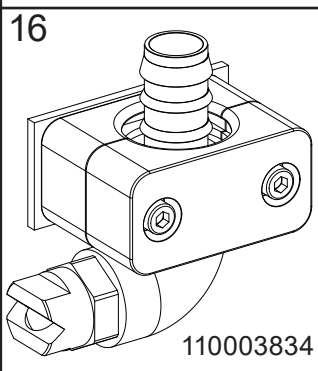

Pos./Ref.	Nr. No.	Description Beschreibung Désignation Designación	Cerberus
1	110003841	Display Complete	1
2	110003277 (0602045)	Screw kit	
3	110003730	Controller board	1
4	110003839	EI-box Complete	
5		See page 67	
6	110002787	Solenoid Valve	
7	110007719	Coil	
8	110002788	Regulator unit Air with manometer	
9	531101	Solenoid Valve	
10	110003277 (0602092)	Screw kit	
11	110003285	Air Connection	
12	110001066	Wallbracket Complete	
13	110003277 (0607929)	Screw kit	
14	110003842	Suction Lance	
15	652800	Can Holder	
16	0607944	Nozzle Kit	
17	0607945	Nozzle kit	
18	110003844	Sensor kit	

Español (ES)

Français (FR)

Deutsch (DE)

English (EN)

Cerberus

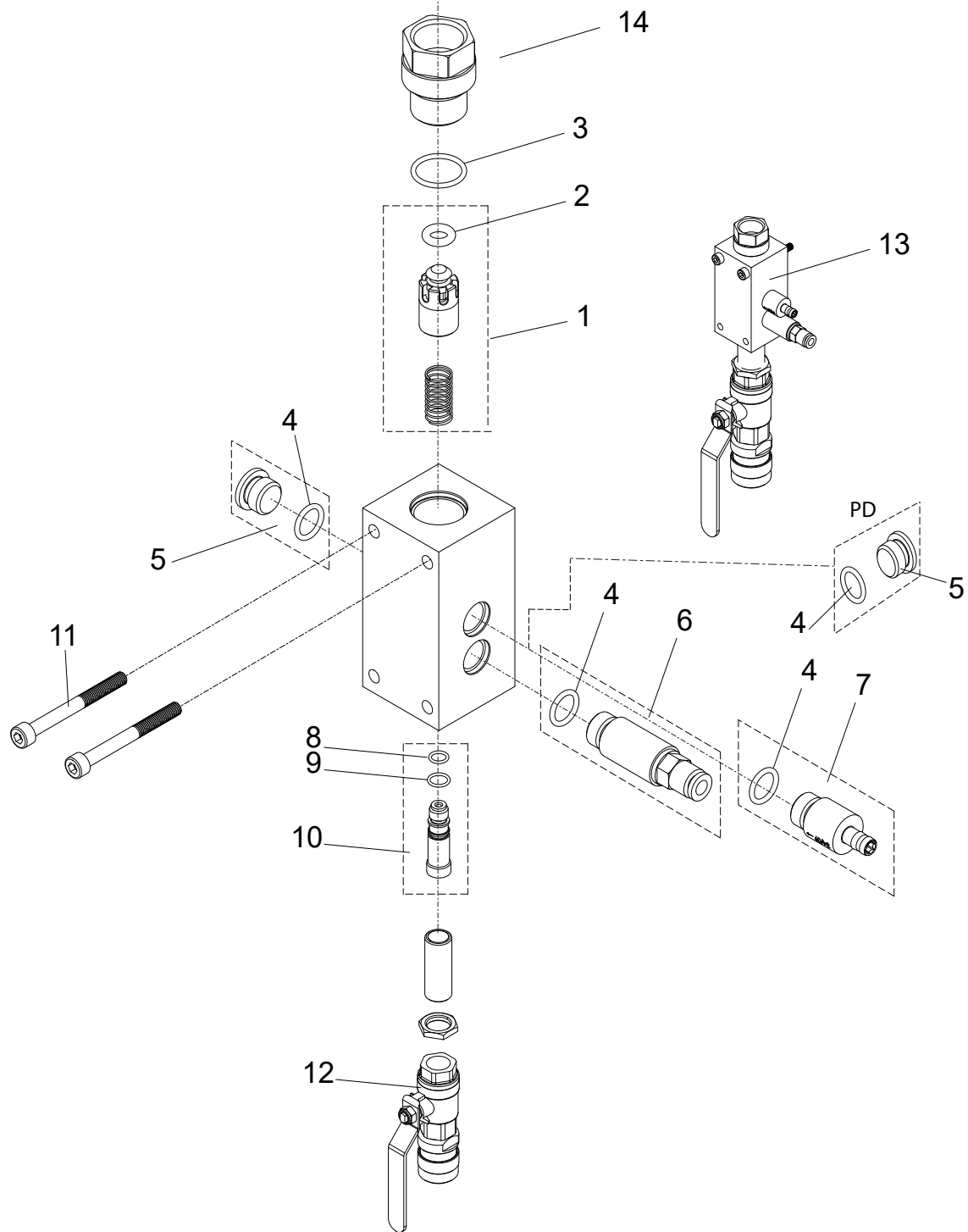

110003771

Pos./Ref.	Nr. No.	Description Beschreibung Désignation Designación	Cerberus
1	110003641	Water non return valve complete	1
2	110003276 (110002785)	O-ring kit	
3	110003276 (350108)	O-ring kit	
4	110003276 (110002952)	O-ring kit	(2)
5	110002306	Plug incl O-ring	(2)
6	110001979	Air non return valve complete	1
7	110001102	Chemical non return valve	2
8	110003276 (110004888)	O-ring kit	
9	110003276 (110004887)	O-ring kit	
10	110004069	Injector kit	
11	110003277 (0602028)	Screw kit	
12	110003682	Outlet complete	
13	110003745	Block complete	
14	110003318	Fitting for non return valve	

Español (ES)

Français (FR)

Deutsch (DE)

English (EN)

EI diagrams

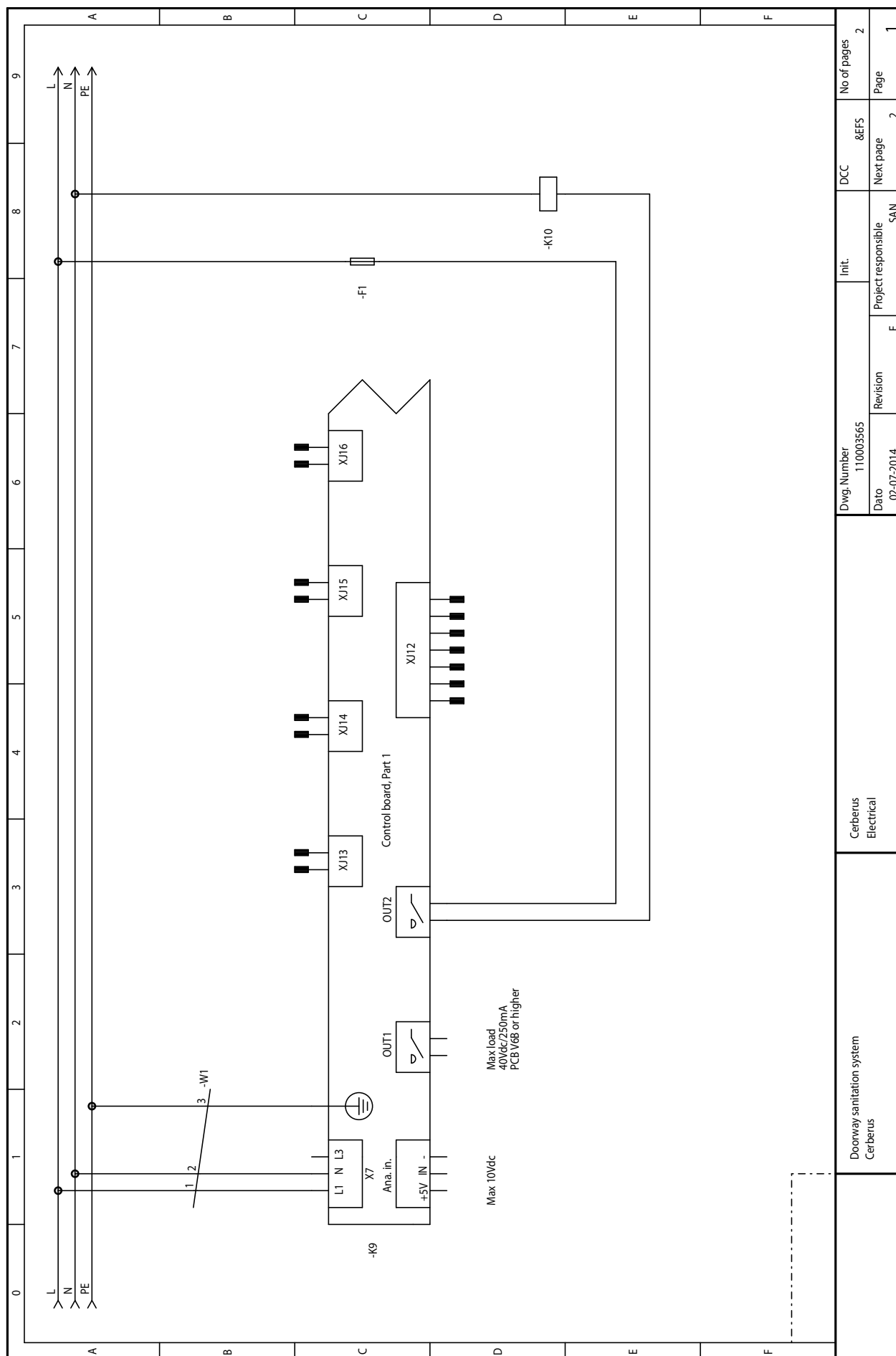

EI diagrams

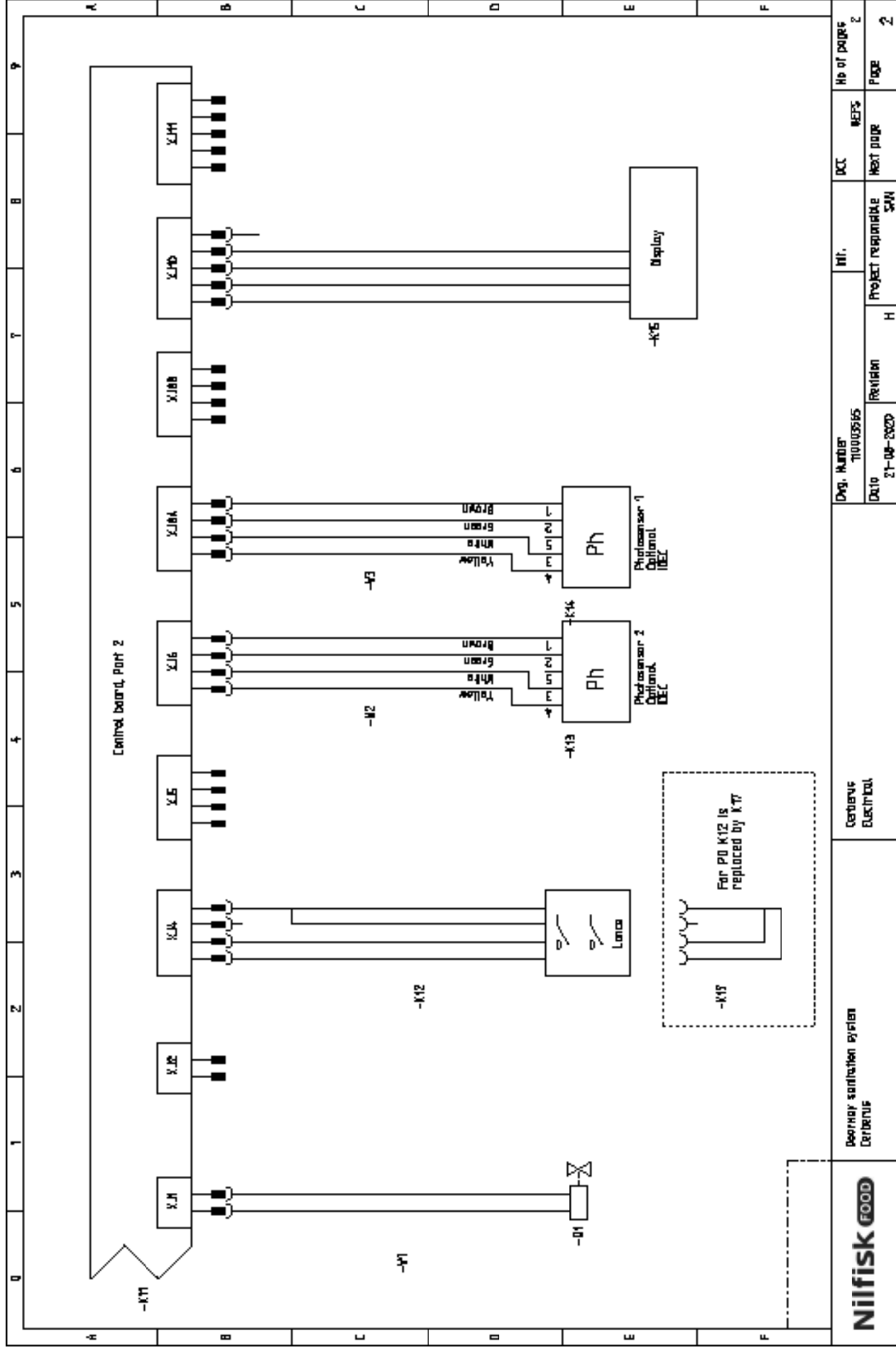

Nilfisk FOOD

Beerday sanitation system
Cerberus

Cerberus
Electrical

Doc. Number
7100103565

Date
21-08-2020

Inf. Project responsible
H

Revision
SM

DCC Next page

Page
2

Ho of pages
2

Operating Diagrams

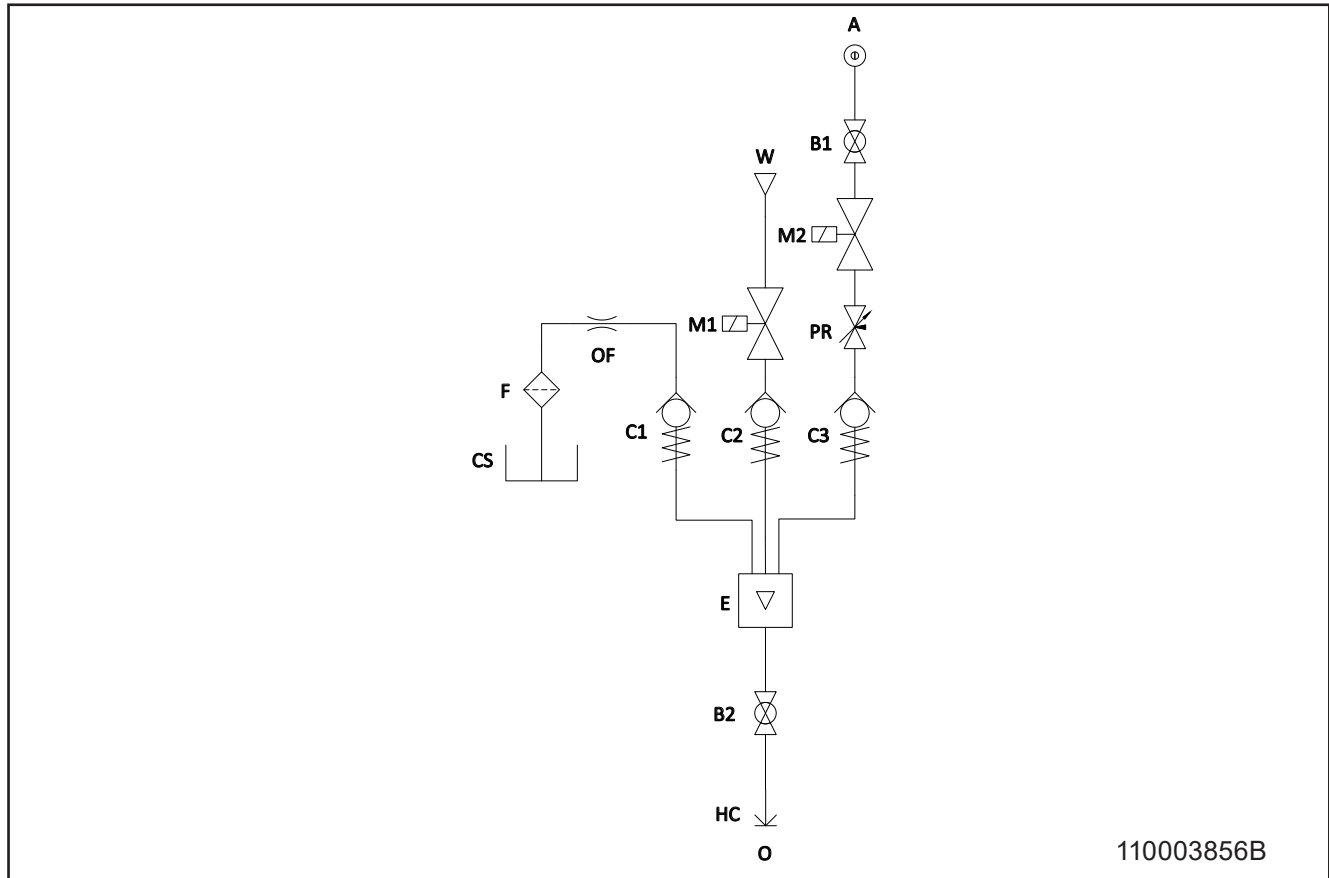

	English	Deutsch	Français	Español
A	Air supply	Lufteingang	Alimentation air	Suministro de aire
B	Ball valve	Kugelventil	Clapet à bille	Válvula esférica
C	Check valve	Rückschlagventil	Soupape de non retour	Válvula de retención
CS	Chemical supply	Chemische Versorgung	Fourniture de produits chimiques	Toma de suministro de productos químicos
E	Ejector	Ausstoß	Ejecteur	Eyector
F	Filter	Filter	Filtre	Filtro
HC	Hose connection	Schlangenverbindung	Connexion flexible	Conexión de tubo flexible
M	Solenoid valve	Magnetventil	électrovanne	La válvula de solenoide
O	Outlet	Ausgang	Sortie	Salida
OF	Orifice	Blende	Orifice	Orificio
PR	Pressure regulator	Druckregler	Régulateur de pression	Régulador de presión
W	Water inlet	Wassereinlassrohr	Admission d'eau	Toma de agua

Installation

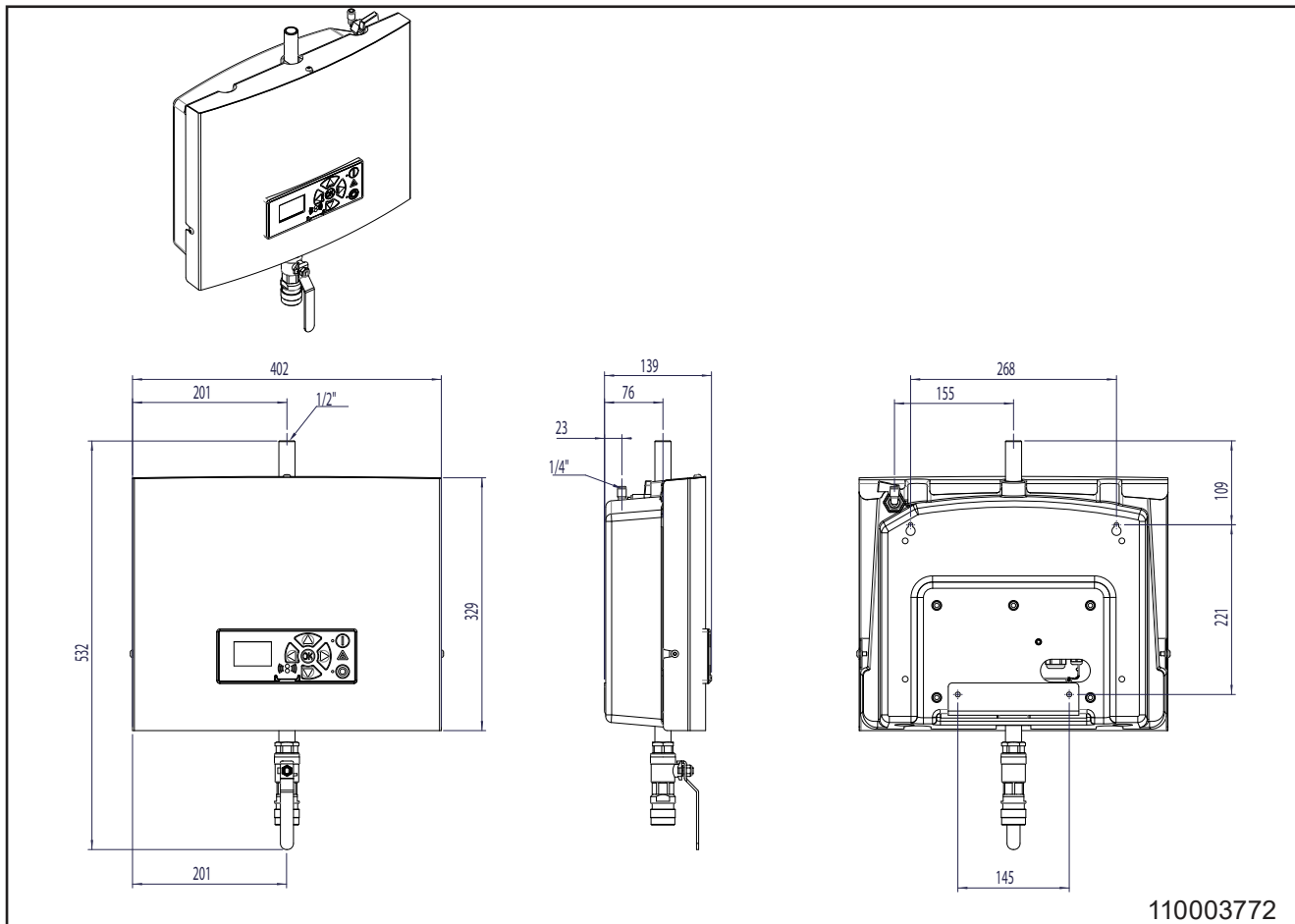
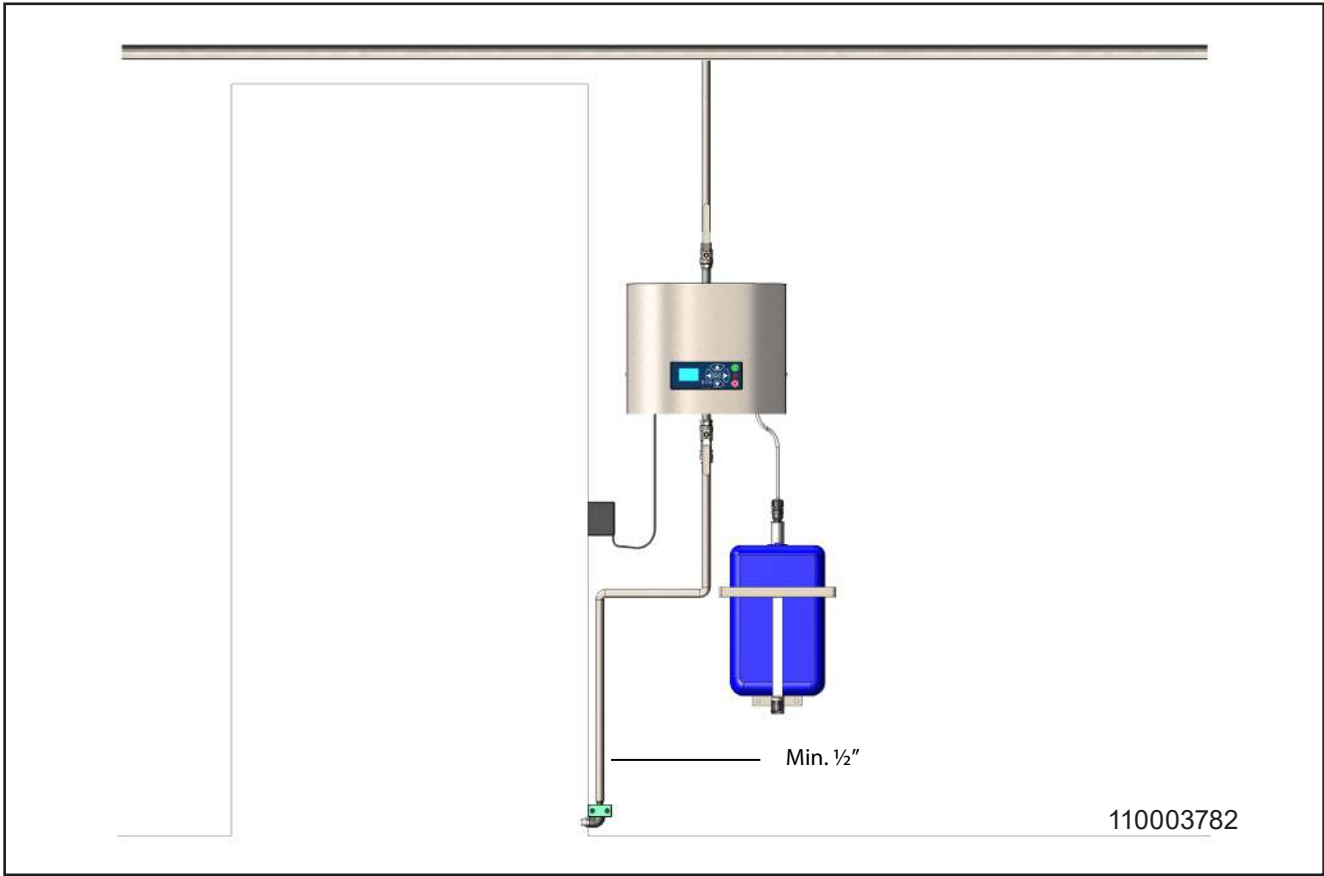

Mounting

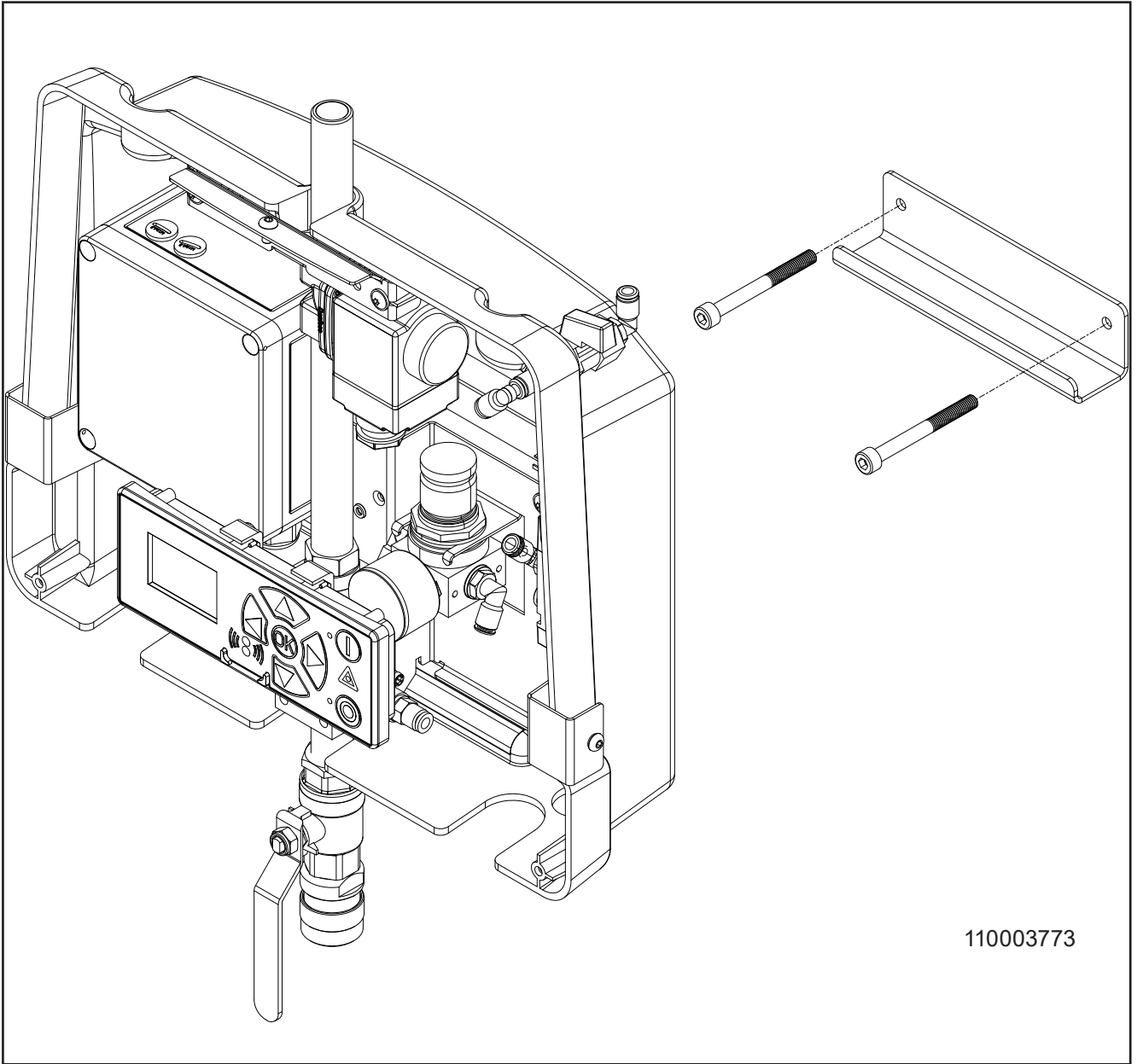

110003773

Layout Cerberus



Cerberus

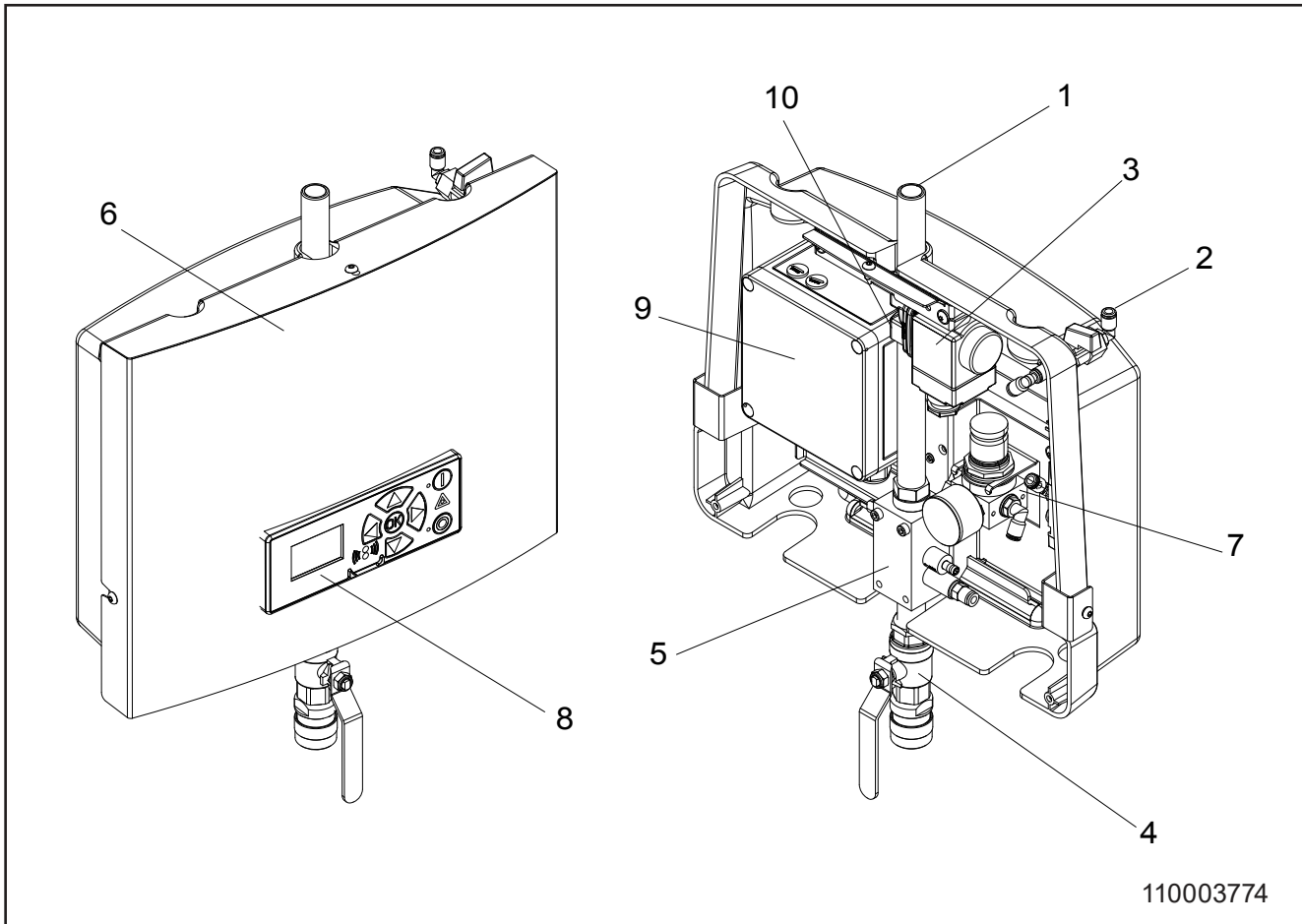

	English	Deutsch	Français	Español
1	Water inlet	Wassereintritt	Entrée d'eau	Entrada de agua
2	Inlet air	Ansaugluft	Entrée d'air	Entrada de aire
3	Coil	Spule	Bobine	Bobina
4	Quick coupling with check tap	Schnellkupplung mit Kontrollöffnung	Raccord rapide avec robinet de contrôle	Acoplamiento rápido con regulador de retención
5	Multi Injector Cerberus	Mehrfacheinspritzer Cerberus	Multi injecteur Cerberus	Inyector múltiple Cerberus
6	Cover	Abdeckung	Couvercle	Cubierta
7	Air inlet with manometer	Lufteintritt mit Manometer	Entrée d'air avec manomètre	Entrada de aire con manómetro
8	Display	Anzeigen	Afficher	Visualización
9	EI-Box	Elkasten	Boîtier électrique	Caja eléctrica
10	Solenoid valve	Magnetventil	électrovanne	La válvula de solenoide
11	Solenoid valve	Magnetventil	électrovanne	La válvula de solenoide

Printed in Denmark

No.: 110003776NO 10/2020
Serial no: 113.02.000XXX

© 2014 All rights reserved
Distributor:

Nilfisk **FOOD**