

12. Spare parts / Ersatzteile / Pièces détachées / Piezas de recambio

EN



The parts marked as recommended spare parts are parts that will need replacement after some time depending usage.

The parts marked as inspection parts are parts that should be checked every year for defects and replaced as needed.

DE



Die Teile, die als empfohlene Ersatzteile markiert sind, sind Teile, die in Abhängigkeit vom Gebrauch nach einiger Zeit ausgetauscht werden müssen.

Die Teile, die als Prüfteile markiert sind, sind Teile, die jährlich auf Defekte geprüft und bei Bedarf ersetzt werden müssen.

FR



Les pièces marquées comme pièces de rechange recommandées sont des pièces qui devront être remplacées après un certain temps selon l'utilisation.

Les pièces marquées en tant que parties d'inspection sont des pièces qui doivent être vérifiées chaque année pour les défauts et remplacées au besoin.

ES



Las piezas marcadas como piezas de repuesto recomendadas son las que necesitará sustituir después de un tiempo, según el uso que le dé.

Las piezas marcadas como piezas de inspección son piezas que deberían revisarse cada año para detectar defectos y sustituirlas en caso de ser necesario.

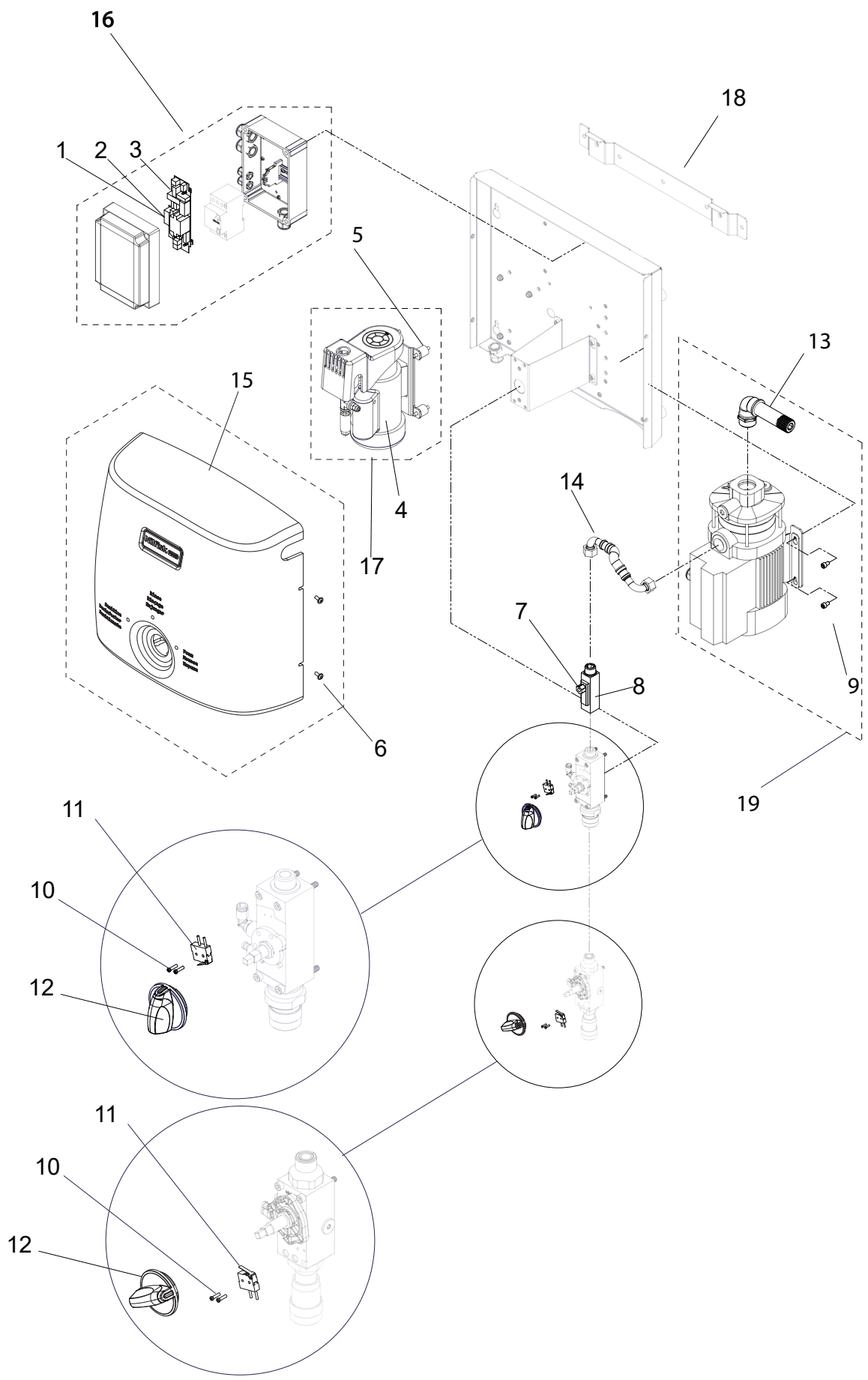

110003058D

!	Pos./Ref.	Nr. No.	Description Désignation Designación	XP Foamer 50 Hz	XP Foamer 60 Hz
•	1	110003742	Fuse 12 A	1	1
•	2	110003743	Fuse 0,315 A	1	1
•	3	110003701	Controller board	1	1
•	4	110003159	Hose Teflon	1	1
	5	110003173	Mounting kit for the compressor	1	1
	6	110003168	Screws for Cover	4	4
	7	110003165	Red switch for Flow switch	1	1
•	8	110002638	Flow switch serial no → 103.01.000XXX	1	1
•	8	110008886	Flow switch serial no 160.01.000XXX →	1	1
	9	110003169	Screws for pump & bracket	4	4
	10	110003170	Screws for compressor switch	2	2
•	11	110002636	Compressor switch	1	1
	12	909100249	Selector knob	1	1
	13	110003688	Water inlet connection kit	1	1
	14	110005172	SS Braided Hose	1	1
	15	110002630	Frontcover cpl. serial no → 103.01.000XXX	1	1
	15	110009013	Frontcover cpl. serial no 160.01.000XXX →	1	1
	16	110002760	Elbox cpl.	1	1
	17	110003699	Compressor cpl. 50 Hz	1	
	17	110003700	Compressor cpl. 60 Hz		1
	18	110002629	Wall bracket cpl.	1	1
	19	110003697	Pump cpl. 50 Hz	1	
	19	110003698	Pump cpl. 60 Hz		1

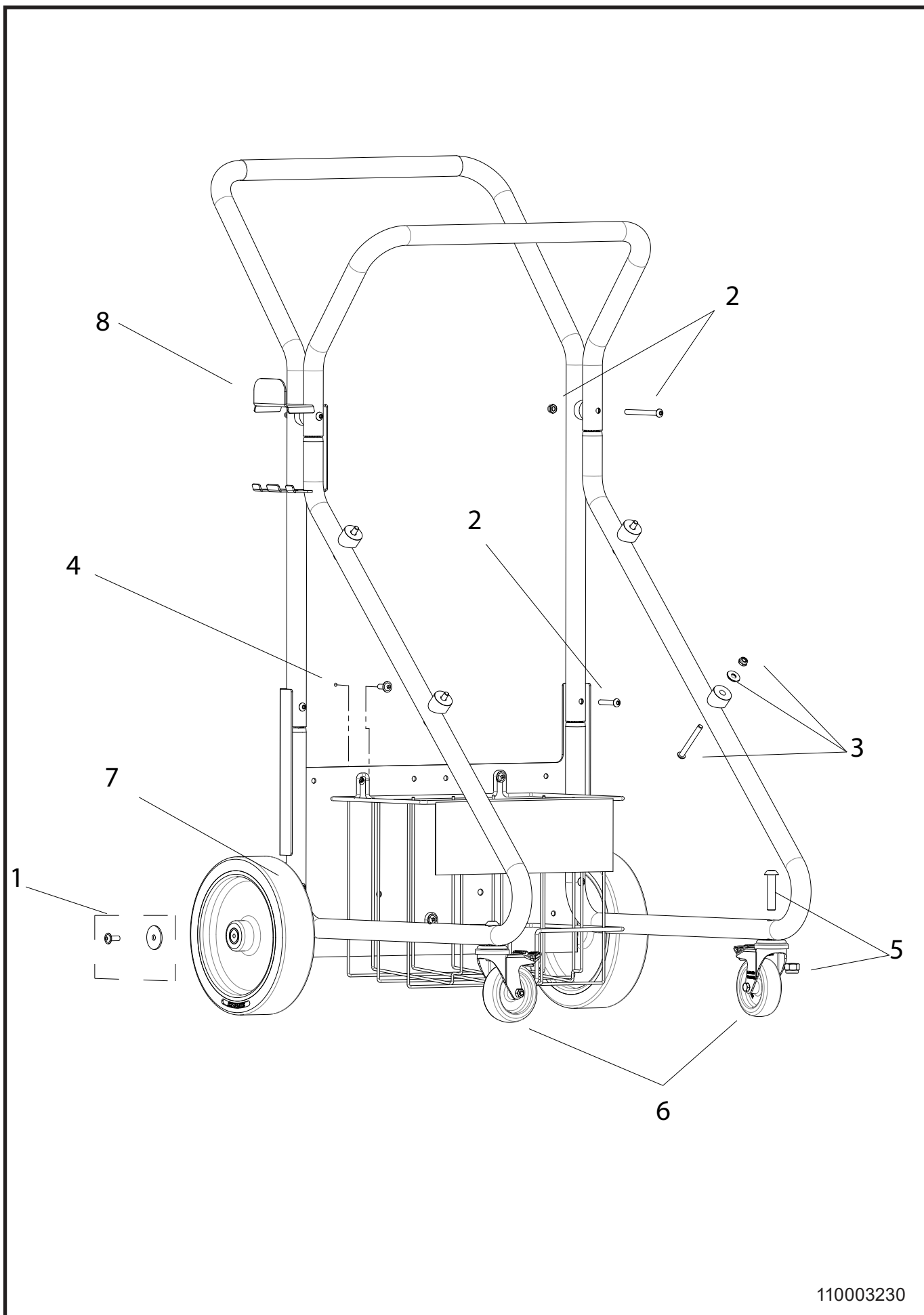

110003230

!	Pos./Ref.	Nr. No.	Description Désignation Designación	XP Foamer 50 Hz	XP Foamer 60 Hz
	1	110003205	Mounting kit for cart		
	2	110003204	Mounting kit for unit on cart		
	3	110003197	Mounting kit productholder		
	4	110003207	Mounting kit for caster		
	5	110003206	Mounting kit for wheels		
	6	110003177	Castor cpl.		
	7	110003176	Back wheel cpl.		
	8	110004658	Bracket for nozzles and cables		

Block Complete
Serial no.: → 103.01.000XXX

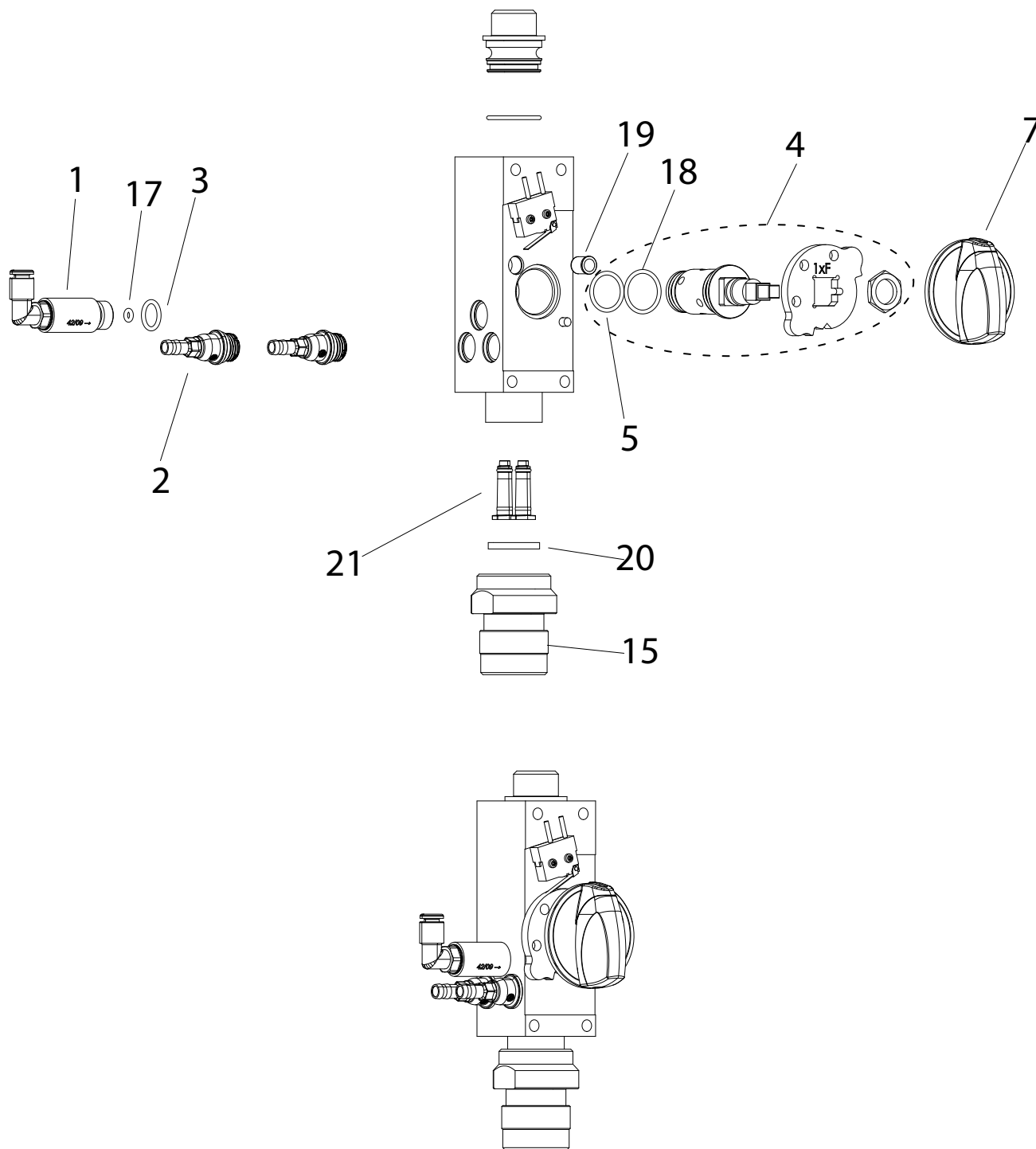

110006636

!	Pos./Ref.	Nr. No.	Description Désignation Designación	XP Foamer 50 Hz	XP Foamer 60 Hz
*	1	110003096	Air Check valve	1	1
*	2	110004434	Product check valve	2	2
*	3	110005516 (110002952)	O-ring kit		
	4	110002501	Selector valve axel	1	1
*	5	110005516 (110002956)	O-ring kit		
	6	110005516 (110003172)	O-ring kit		
	7	909100249	Selector knob	1	1
		110002633	Block cpl.	1	1
	15	110002985	Coupler	1	1
	17	110005516 (0635021)	O-ring kit		
	18	110005516 (110002955)	O-ring kit		
	19	110002392	Flexible pressure piece	1	1
	20	110005516 (110002961)	O-ring kit		
	21	110004219	Injector kit	1	1

English (EN)

Deutsch (DE)

Français (FR)

Español (ES)

Block Complete

Serial no.: 160.01.000xxx →

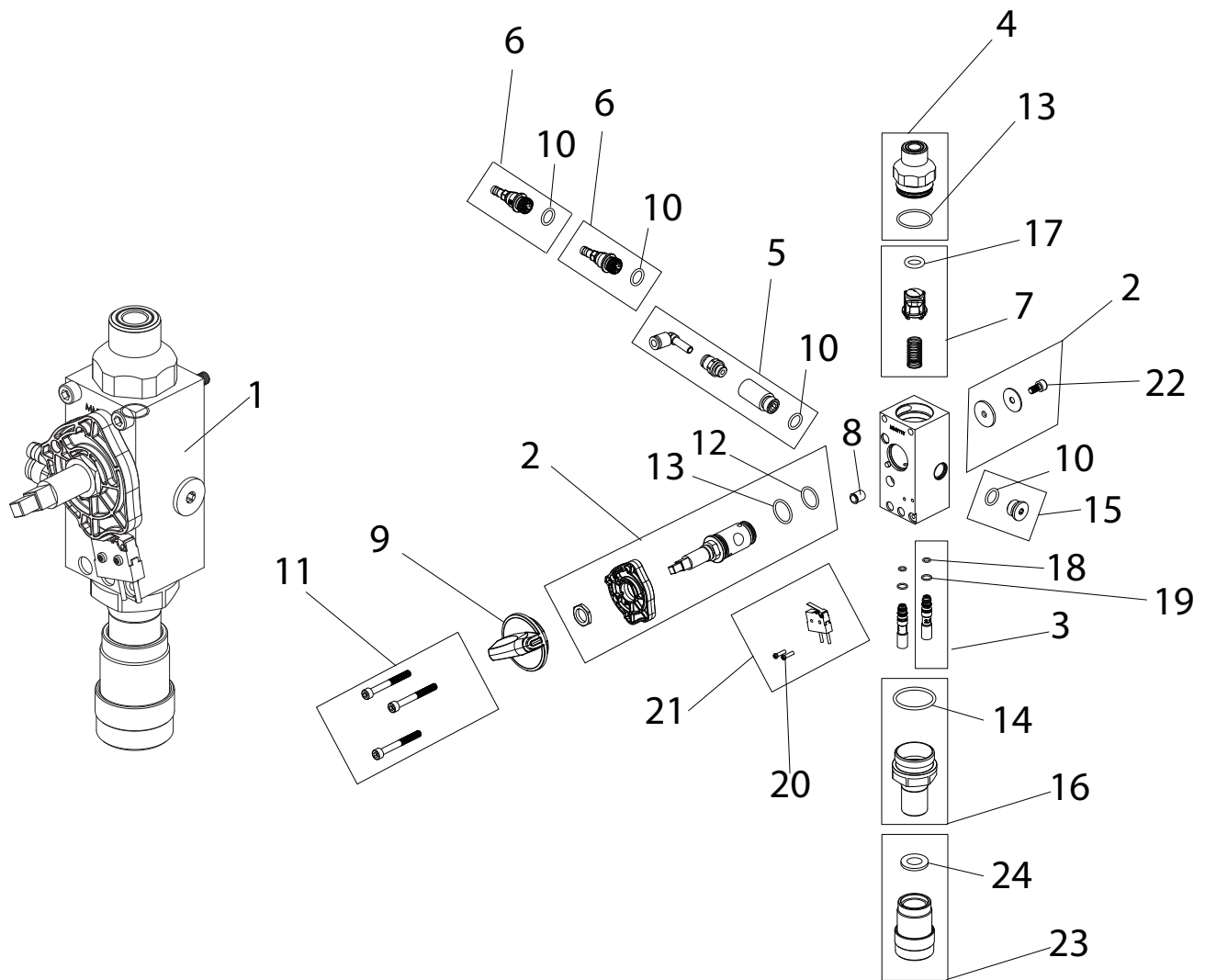

110008817B

!	Pos./Ref.	Nr. No.	Description Désignation Designación	XP Foamer 50 Hz	XP Foamer 60 Hz
1		110008809	Block complete	1	1
2		110007101	Axle complete	1	1
3		110008891	Injector kit	1	1
4		110008889	Inlet connection kit	1	1
5		110007136	Air non return valve with fitting	1	1
6		110004434	Plast chemical non return valve	2	2
7		110008772	Water non return valve	1	1
8		110002392	Flexible pressure piece	1	1
9		909100249	Selector knob	1	1
10		110005516 (110002952)	O-ring kit		
11		110008896 (110000526)	Screw kit		
12		110005516 (110002508)	O-Ring kit		
13		110005516 (350108)	O-Ring kit		
14		110005516 (110000038)	O-Ring kit		
15		110002306	Plug	1	1
16		110008897	Outlet Fitting	1	1
17		110005516 (110008303)	O-ring kit		
18		110005516 (110004888)	O-ring kit		
19		110005516 (110004887)	O-ring kit		
20		110008896 (110002393)	Screw kit		
21		110002636	Compressor switch	1	1
22		110008896 (0600009)	Screw kit		
23		110008897	Outlet coupling	1	1
24		110005516 (110004076)	O-ring kit		

English (EN)

Deutsch (DE)

Français (FR)

Español (ES)

1. Electrical Diagrams

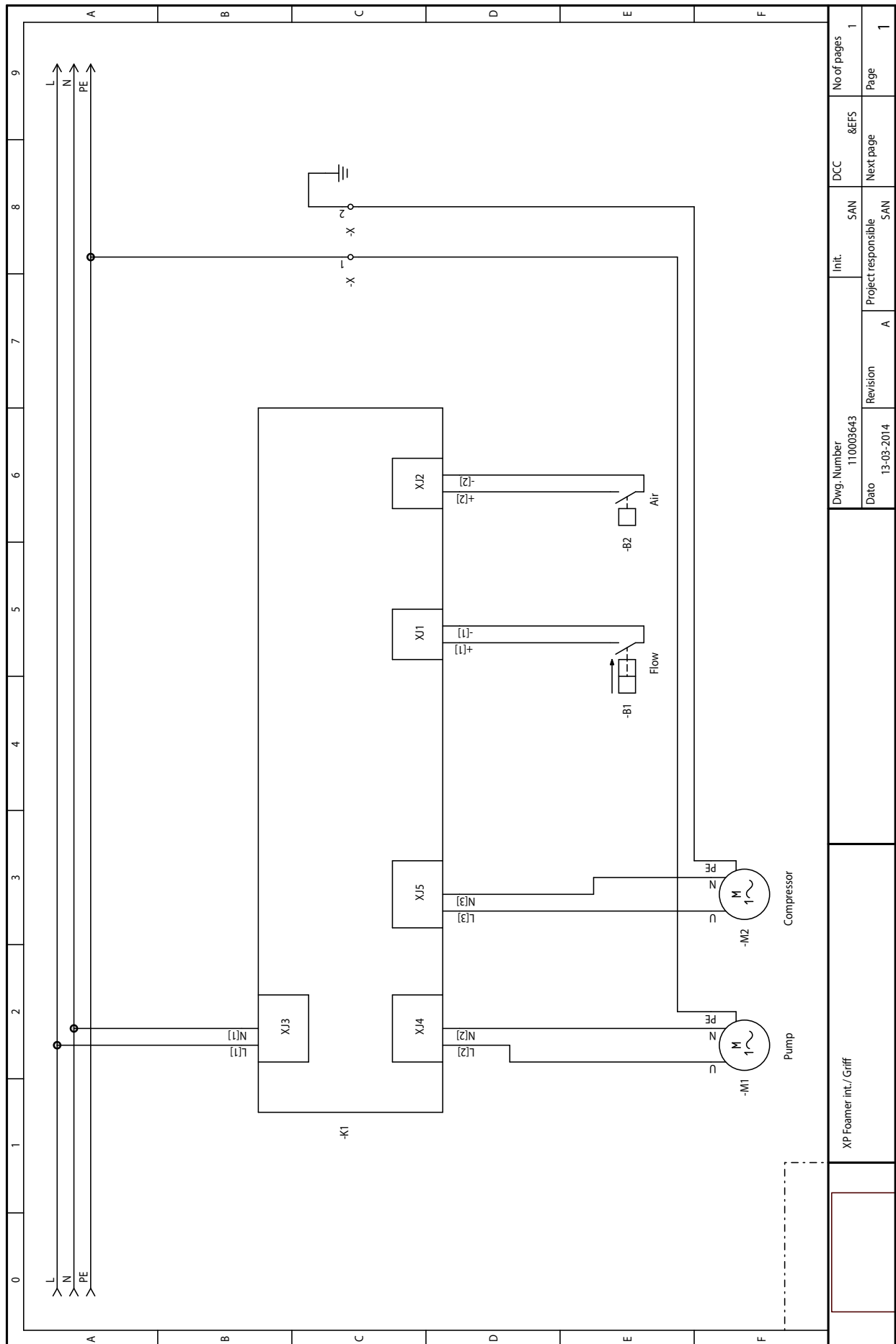

2. Pumpecurve

96806794 CM1-5 50 Hz

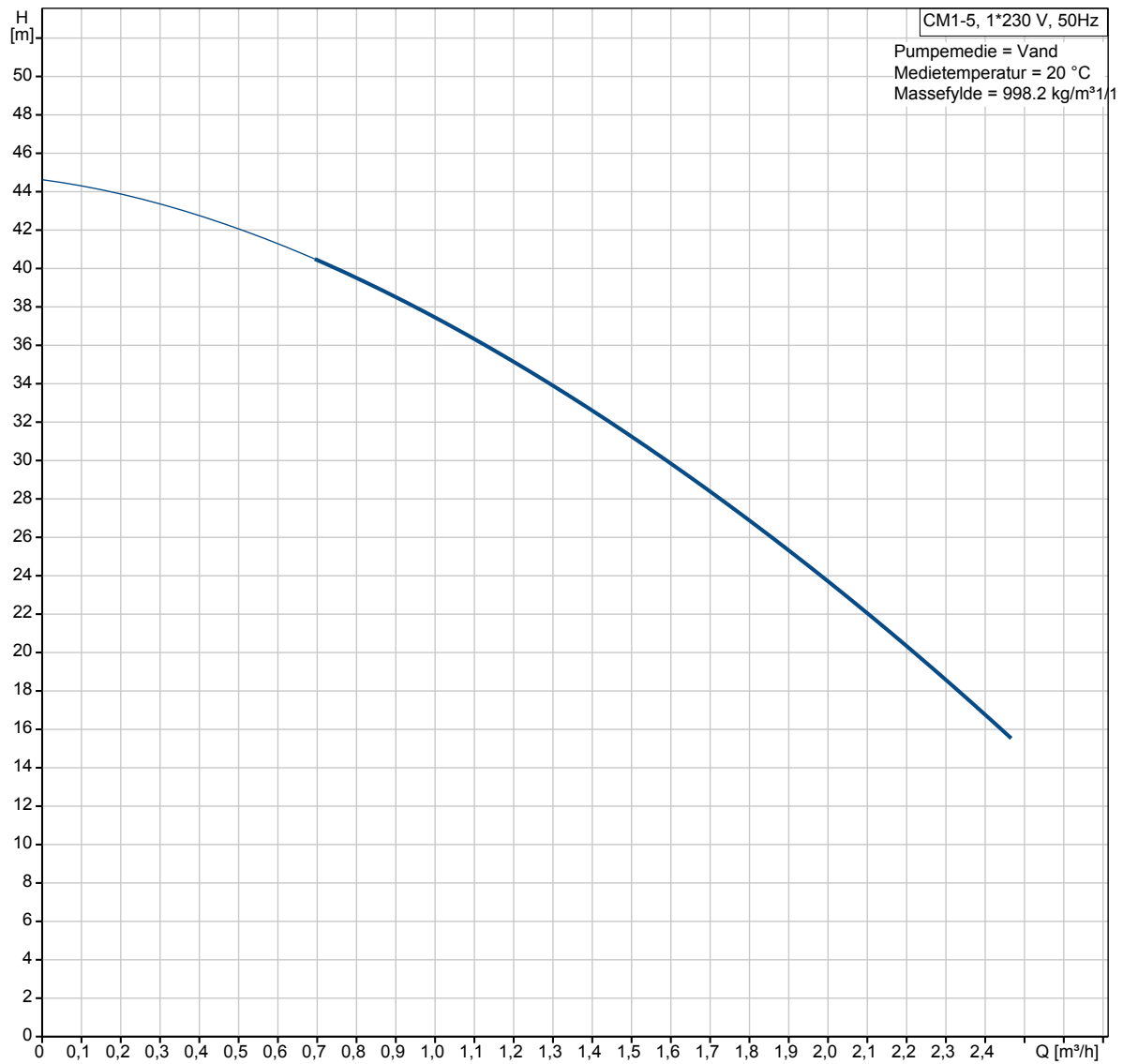

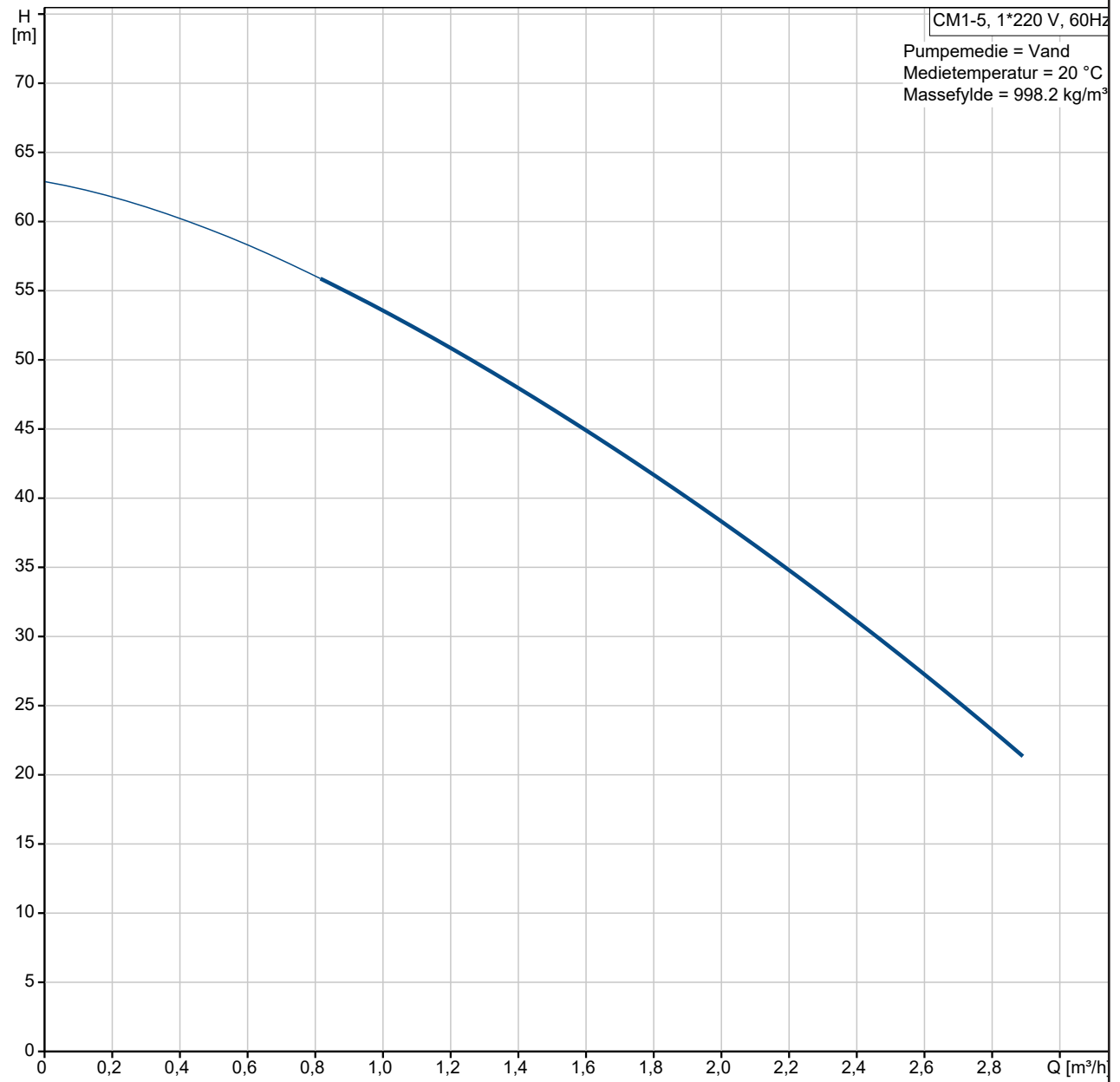
96935536 CM1-5 60 Hz

3. Installation

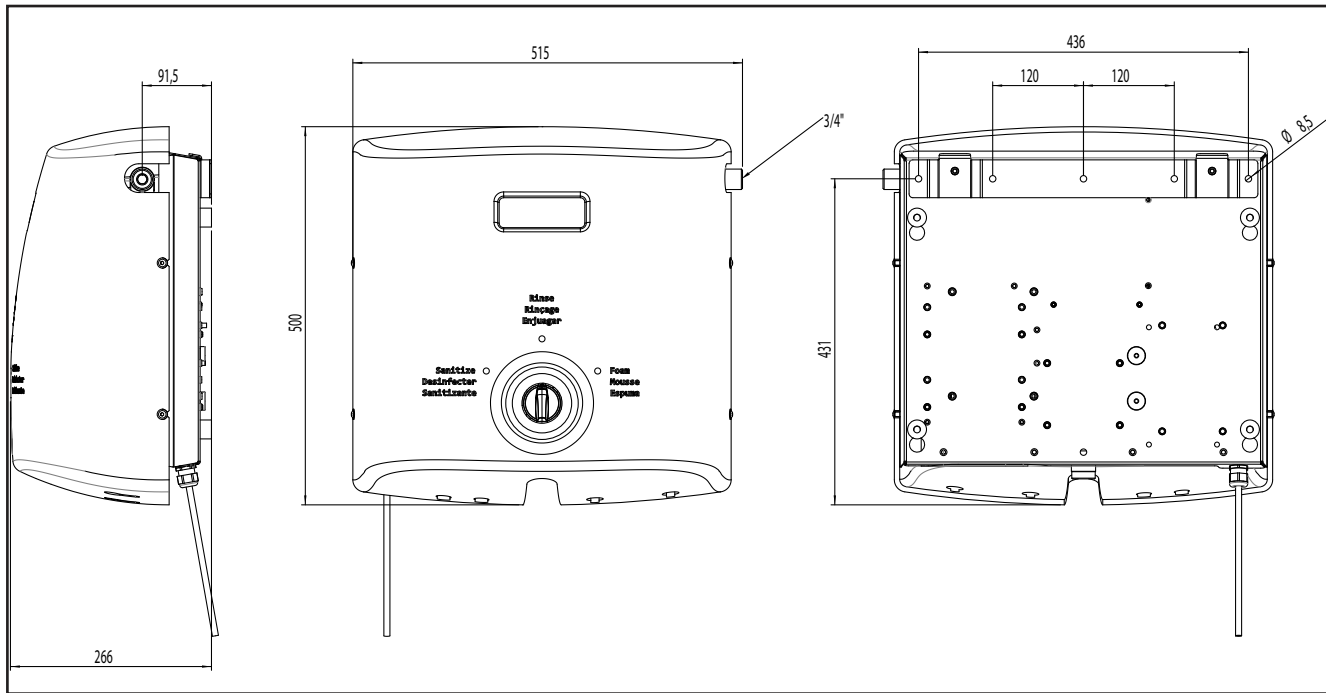

110004860A

Printed in Denmark

No.: 110003630ZC 09/2022
Serial no: 160.01.000XXX

© 2013 All rights reserved

ECOLAB Engineering GmbH,
F & B Engineering Competence Centre EMEA,
Raiffeisenstraße 7,
D-83313 Siegsdorf
Telephone.: (+49) 86 62 /61 0 - Fax: (+49) 86 62 / 61 2 35
e-Mail: engineering-mailbox@ecolab.com

ECOLAB®